

CHAPTER 12

Thermal Management



Featured Products in this Chapter

- ▶ Outdoor Air Conditioners
T15, T20 and T29 Series
800-4,000 BTU/Hr. P. 1156
- ▶ Outdoor Air Conditioners
T43, T50 and T53 Series
6,680-20,000 BTU/Hr. P. 1160



CHAPTER CONTENTS

Thermal Management Design Guide

Thermal Management Design Guide

Thermal Management Design Guide Overview . . .1138

Types of Cooling1138

Air Conditioner1138

Vortex Cooler1138

Heat Exchanger1138

Filter Fan and Exhaust1138

Finding the Right Thermal Management Solution1139

Multiple Air Movers for Open Loop Systems . . .1140

Multiple Exhausts for Open Loop Systems . . .1140

Internal Circulating Fans1140

Acoustical Noise1141

Air Conditioners

Air Conditioners Sizing and Selection

Air Conditioners Sizing and Selection Overview . 1142

How to Read Air Conditioner Catalog Numbers . 1142

Thermal Management Sizing and Selection Software1142

Air Conditioner Sizing1143

SPECTRACOOL™ Air Conditioners1144

Type 4, 12, 3R T4 Line Indoor/Outdoor Air Conditioners1144

Type 12 Side-Mount Subcompact Air Conditioners1144

Type 12 GENESIS™ Side-Mount Compact Air Conditioners1145

Type 12 GENESIS™ Side-Mount Mid-Size Air Conditioners1145

Type 12 GENESIS™ 3-Phase 460-Volt Side-Mount Full-Size Air Conditioners1146

Type 12 GENESIS™ Top-Mount Air Conditioners . 1146

Type 12, 3R CR Series Air Conditioners1147

Type 4X CR Series Air Conditioners1147

Type 12, 4, 4X VC Vortex Cooler1147

Air Conditioners

SPECTRACOOL™ Air Conditioners - 4,000 and 6,000 BTU1148

SPECTRACOOL™ Air Conditioners - 8,000 and 12,000 BTU1150

SPECTRACOOL™ Air Conditioners - 20,000 BTU . . 1154

Outdoor Air Conditioners T15, T20 and T29 Series 800-4,000 BTU/Hr.1156

Outdoor Air Conditioners T43, T50 and T53 Series 6,680-20,000 BTU/Hr.1160

Side-Mount Subcompact Air Conditioner1166

GENESIS™ Side-Mount Compact Air Conditioner . 1168

GENESIS™ Side-Mount Mid-Size Air Conditioner . 1170

GENESIS™ 3-Phase 460-Volt Side-Mount Full-Size Air Conditioner1174

GENESIS™ Top-Mount Series Air Conditioner . . . 1176

CR Compact, Mid-Size and Full-Size Air Conditioners and Accessories1178

Closed Loop Cooling1183

Vortex Cooling Systems and Accessories

Vortex Cooling System1184

Heat Exchangers

Heat Exchangers Sizing and Selection

Heat Exchangers Sizing and Selection Overview . 1188

When Should You Use a Heat Exchanger?1188

How to Read Heat Exchanger Catalog Numbers . 1188

Heat Exchanger Sizing1188

Compact and Mid-Size Heat Exchangers1189

Thermal Management Sizing and Selection Software1189

Heat Exchangers

CLIMAGUARD™ Outdoor Heat Exchangers1190

XR Series Compact and Mid-Size Heat Exchanger1198

Fans, Blowers, Louvers and Vents

Fans, Blowers, Louvers and Vents Sizing and Selection

Fans, Blowers, Louvers and Vents Overview . . . 1202

Determine the Required Fan/Blower Size (Volume Airflow)1202

How to Read Filter Fan Package Catalog Numbers1203

Thermal Management Sizing and Selection Software1203

Cooling Fan and Blower Selection1203

Compact Cooling Fans1204

Cooling Fan Packages1204

Filter Fan Packages1204

Blower Package1205

Louvers and Vents1205

Compact Cooling Fans and Accessories

Compact Cooling Fans1206

Fan Filter and Finger Guard Kit1208

Fan Cords1208

Fan Brackets1209

Finger Guards1209

Cooling Fan and Exhaust Packages and Accessories

Cooling Fan and Exhaust Packages1210

Exhaust Grilles1213

Optional Grilles and Replacement Filters1213

EMC Fan/Grille Upgrade Kit1213

How to Choose a Filter Fan

How to Choose a Filter Fan Overview1214

Voltage Input1214

Enclosure Protection1214

Airflow1214

How to Derive Filter Fan Airflow

Step 1. Determine Delta-T (ΔT)1215

Step 2. Determine Internal Heat Load1215

Step 3. Determine Free Airflow1216

A Friendly Reminder1217

Step 4. Estimate System Impedance1217

Step 5. Select Your Filter Fan1217

Filter Fan Packages

SF04 16 CFM (28 m³/hr.) Side-Mount Filter Fan . . 1218

SF05 39 CFM (66 m³/hr.) Side-Mount Filter Fan . . 1220

SF09 75 CFM (127 m³/hr.) Side-Mount Filter Fan . 1223

ST10 100 CFM (170 m³/hr.) Thin Side-Mount Filter Fan1226

SF10 162 CFM (275 m³/hr.) Side-Mount Filter Fan 1229

ST13 303 CFM (515 m³/hr.) Thin Side-Mount Filter Fan1232

SF13 376 CFM (638 m³/hr.) Side-Mount Filter Fan . 1235

SF13 473 CFM (803 m³/hr.) Side-Mount Filter Fan 1238

SF13 571 CFM (970 m³/hr.) Side-Mount Filter Fan 1240

SR16 280 CFM (475 m³/hr.) Roof-Mount Filter Fan 1242

SR16 459 CFM (780 m³/hr.) Roof-Mount Filter Fan 1243

Exhaust Grilles1244

Replacement Filters1244

Wind-Driven Rain and Washdown Shroud1245

Outdoor Filter Fan and Exhaust Package1245

Blower Fan Package

Blower Fan Package1247

Exhaust Grille and Filter for Blower Package . . . 1248

Fan Accessories

Filter and Fan Airflow Monitor1249

Fan Speed Controls1250

19-in. Rack-Mount Fan Tray1251

Fan Shroud Kit, Type 3R1252

Louvers and Vents

Louver Plate Kits1253

Filters for Louver Plate Kits1253

Vent Kit1254

Ventilators1254

Filter Adhesive1254

Heaters

Heaters Sizing and Selection

Heaters Sizing and Selection Overview1256

Semiconductor Control Panel Heaters (for 10-60 W Heating Applications)1256

Electric Heaters (for 100-800 W Heating Applications)1257

Semiconductor Control Panel Heaters1257

Electric Heaters1257

Heaters

Semiconductor Control Panel Heater1258

Electric Heater1260

Accessories

Controllers

Electronic Hygrotherm1262

Mechanical Hygrostat1263

Dual Thermostat1264

Temperature Control Switches1265

Condensation Devices

H2OMIT® Vent Drains, Type 4X1266

H2OMIT® Thermoelectric Dehumidifier1268

Thermal Management Design Guide Overview

Incorporating thermal cooling within an enclosure can lengthen system life and increase control line reliability. The accumulation of heat in an enclosure is potentially damaging to electrical and electronic devices. Overheating will shorten the life expectancy of costly electrical components and can lead to catastrophic failure. It is, therefore, important that system designers be aware of the temperature implications of their designs prior to implementation and, where necessary, take steps to reduce heat build-up inside the enclosure.

Extreme temperatures can have the following effects on industrial control equipment:

- Catastrophic failures can occur
- Silicone material properties can change
- Drive performance is de-rated
- I/C-based devices may experience intermittent fluctuations in output and voltage migration
- Mean Time Between Failure (MTBF) decreases exponentially

The costs when a line goes down due to temperature extremes are:

- Productivity losses
- Increased labor costs
- Increased scrap
- Opportunity losses
- Component costs
- Missed ship dates
- Decreased customer satisfaction

Types of Cooling

Open Loop: Utilizes the ambient or outside air, filtered or unfiltered, to cool the electronics

Closed Loop: Maintains the sealed integrity of the cabinet while utilizing the internal cabinet air to cool the electronics

Active Cooling: An external device enhances the cooling process

Passive Cooling: Cooling occurs via natural convection and heat dissipation

Air Conditioner

Closed Loop System: Can maintain a Type 3R, 12, 4 or 4X rating and can create an environment cooler than ambient. This is an ideal type of cooling which creates a more reliable system and improves equipment life cycle. A typical internal temperature design point is 85-95 F. Hoffman air conditioners are designed for continuous operation in ambient environments up to 125 F or 131 F, depending on the model.

For sizing and selecting an air conditioner, refer to the Hoffman Thermal Management Catalog, or go to hoffmanonline.com to use the Thermal Management Sizing and Selection Software.

When an electrical enclosure wall is penetrated with an opening it must be covered by a rated part. All of the above cooling systems have been designed and certified to be used on electrical enclosures and maintain the product Type Rating identified on the corresponding product specification sheet.

Vortex Cooler

Closed Loop System: Can maintain a Type 12, 4 or 4X rating and can create an environment cooler than ambient. This is an ideal type of cooling for smaller enclosure applications where compressed air is available.

Heat Exchanger

Closed Loop System: Maintains a sealed system that will match the Type rating of the heat exchanger. Temperature will always be greater than ambient. Equipment inside the enclosure must be evaluated to sustain a worst-case temperature rise above ambient.

For sizing and selecting heat exchangers, refer to Heat Exchangers Sizing and Selection.

Filter Fan and Exhaust

Open Loop Systems: Usually only used in relatively clean Type 1 or Type 3R environments where the temperature inside the enclosure will always be greater than outside the enclosure. Equipment inside the enclosure must be evaluated to sustain a worst-case temperature rise above ambient.

For sizing and selecting filter fan packages, refer to Fans, Blowers, Louvers and Vents Sizing and Selection.

Thermal Management Design Guide

Finding the Right Thermal Management Solution

To determine the best thermal management products for the application, the user needs to define information about the environment, enclosure and the equipment inside. Use the form below in conjunction with Hoffman's online Thermal Management Sizing and Selection Software.

Project Environment/Thermal Evaluation Data Form

Environment

System Location: Indoors, outdoors shaded or outdoors direct sunlight

Environment: Corrosive, dust, grit, dirt, oily-cutting fluids, washdown, dripping water, freezing rain or other

Open Loop _____ or Closed Loop _____ System

Enclosure

Size: _____ H x _____ W x _____ D = _____

Determine the area that allows heat transfer and identify any dimensional limits of thermal system.

Type Rating: _____ (Typically Type 1, 3R, 12, 4, or 4X)

Enclosure finish/color: _____

(external color will effect solar load if in direct sunlight; if internal finish is metallic, the passive cooling of the enclosure is less)

Equipment

Internal Heat Load: _____ (determine the full-load heat produced by the major power-consuming components; then add an additional 25 percent for passive components and connections)

Determine the level of protection the equipment needs based on the environment.

Identify the most sensitive components relative to temperature or humidity and determine the upper and lower temperature extremes.

Available Power: _____ Volts

Temperature Limits

Cooling Extremes

_____ Maximum temperature outside the enclosure

_____ Maximum allowable temperature inside the enclosure (85–95 F is a typical value used to provide a reliable system and maximize the system's life)

Heating Extremes

_____ Minimum temperature outside the enclosure

_____ Minimum allowable temperature inside the enclosure (heaters are frequently required to maintain temperatures above minimum start-up and to remove condensation)

Thermal Management Design Guide

Internal Circulating Fans



The use of circulating fans in an enclosure will improve heat dissipation by as much as 10 percent. Circulating fans are most commonly employed to eliminate hot spots inside an enclosure.

The graph below illustrates the temperature rise of two identical enclosures except one has an internal circulating fan. Each enclosure has two temperature sensors, one located near the top and the other near the bottom. The top and bottom black curves reflect the temperature in the enclosure without an internal fan. Adding a circulating fan removed the heat stratification.

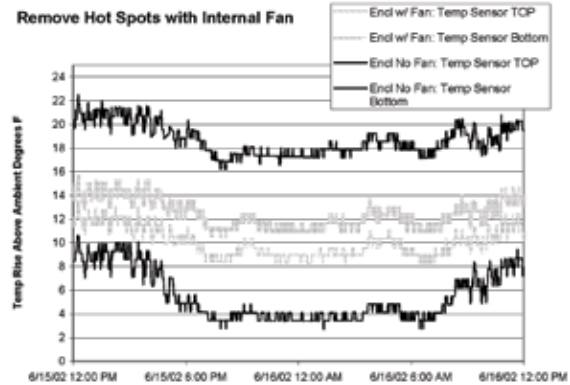

Multiple Air Movers for Open Loop Systems

Air movers can be combined in series or parallel, as this may provide the optimum solution. In addition, a degree of redundancy in the event of fan failure can be a benefit. The graph illustrates how airflow performance changes when air movers are placed in series or parallel with one another in a system.

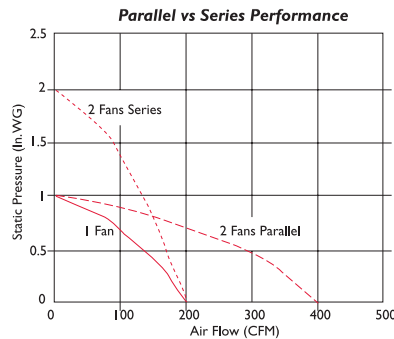

Multiple Exhausts for Open Loop Systems

This performance curve shows that adding a second 10-in. exhaust package provides an increase in airflow from 215 CFM to 290 CFM. The intersection point of the fan curve and the system curve approximates the CFM performance.

Performance Curve for a 10" Cooling Fan Package and System Curve With Exhaust Grills

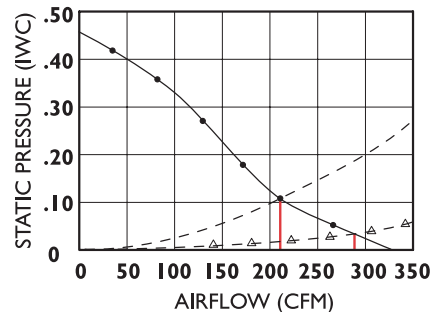

- 10 in. Cooling Fan Package
- - - 10 in. Exhaust Package System Curve 1
- △- Two 10 in. Exhaust Packages System Curve 2

Thermal Management Design Guide

Acoustical Noise

Acoustical noise is typically measured by the Sound Pressure Level (Lp), expressed in decibels and is dependent upon the distance from the source as well as its surroundings.

The Sound Pressure Level is defined as:

$$L_p = 10 \log (\rho^2 / \rho_0^2)$$

Where:

Lp = Sound pressure level (dB)

ρ = Measured sound pressure (Pascals)

ρ₀ = Sound reference level 20 μN/m²

Noise Generated by Air Movers

There are many different ways to reduce the noise generated by an air mover. Some of the more common are:

- Avoid obstructions to airflow
- Run larger fans at lower speeds
- Lower the system impedance
- Minimize inlet losses and obstructions

The most significant factor influencing the noise from a given air mover is the speed of rotation. This is given by the following equation:

$$dB_2 = dB_1 - 50 \log (\text{rpm}_1 / \text{rpm}_2)$$

Where:

dB₁ = Sound pressure of the air mover operating at rpm₁

dB₂ = Sound pressure of the air mover operating at rpm₂

rpm₁ = Operating speed of impeller at condition 1

rpm₂ = Operating speed of impeller at condition 2

Therefore, a blower at half speed will be 15 dB quieter than at full speed. Airflow will also be half and, since static pressure is a squared function of speed, it is reduced by a factor of four.

Decibel Loudness Comparisons

Decibels (dBA)	Loudness Comparisons
10	Grand Canyon at night
20	Quiet basement
30	Quiet bedroom (at night)
40	Typical living room
50	Background music
60	Average human voice
70	Airplane interior noise
75	EPA recommends protection for 8-hour exposure
80	Kitchen garbage disposal
90	Lawn mower
100	Leaf blower
110	Rock concert
115	OSHA forbids unprotected exposure

Sound and Distance **When the distance from a Point source doubles, the sound level decreases six decibels.**

Sound Level	Distance
95 decibels	50 feet
89 decibels	100 feet
83 decibels	200 feet

Addition and Subtraction of Decibel Levels **Doubling sound energy yields an increase of three decibels. In this example, each source is 50dBA. Note the characteristics of logarithmic addition or subtraction of decibel levels.**

Number of Sources	Decibel Level
1	50 dBA
2	53 dBA
4	56 dBA
8	59 dBA

Air Conditioners Sizing and Selection

Air Conditioners Sizing and Selection Overview

Before choosing a thermal management solution, you need to carefully consider the specifics of your application in addition to the following factors:

- Fan packages and blowers may introduce ambient contaminants like oil mist and dust into the enclosure
- Heat exchangers cannot cool below the ambient temperature
- Closed-loop air conditioners (this section) can cool below ambient temperature and reduce humidity without introducing contaminants
- Simple ventilation devices such as louvers or grilles and filters are appropriate if maintaining a cool, constant temperature is not a critical factor

Once you have determined the proper form of cooling equipment you need, select the required cooling capacity as outlined in this section.

How to Read Air Conditioner Catalog Numbers

CR43 - 06 - 1 - 6 - 002

CR43 = Identifies the type/family of air conditioner and the approximate height (i.e., CR43 = CR family, about 43-in. high).

06 = This is the air conditioner's listed capacity in BTU/Hr.
(i.e., 06 = 6000 BTU/Hr.)

1 = 115 Volt; 2 = 230 Volt; 4 = 460 Volt

6 = 50/60 Hz or 60 Hz (depending on unit, see Design Data); 5 = 50 Hz

002 = Unique set of numbers for each air conditioner which identifies the accessories on a model.

Thermal Management Sizing and Selection Software



Designed to assist you in determining the most suitable choices of air conditioners, heat exchangers or fans for your application. Download a free copy of our selection software by visiting our web site: hoffmanonline.com. Click on **Thermal Management** chapter.

Air Conditioners Sizing and Selection

Air Conditioner Sizing

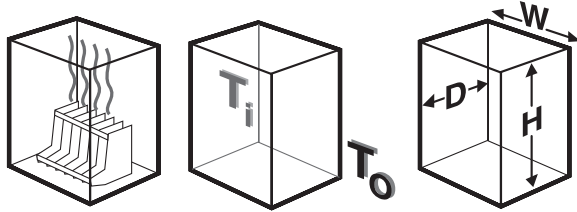

Air conditioners are appropriate for applications in which:

- The temperature inside the enclosure must be maintained at or below ambient temperature.
- Humidity must be removed from the enclosure.
- Ambient air contaminants must be kept out of the enclosure.

The following air conditioner sizing procedure applies to uninsulated, sealed and gasketed enclosures in indoor locations.

Step 1. Determine the internal heat load in watts (W)

Add the maximum heat output specifications for all equipment to be installed in cabinet.

Conversion: 1 W = 3.413 BTU/hr.

Step 2. Determine the desired temperature difference (ΔT) between the ambient temperature and the temperature inside the cabinet

Subtract the desired maximum temperature inside the cabinet (T_i) from the maximum expected temperature (T_o) outside the cabinet.

$$T_o - T_i = \Delta T$$

Conversion: 1 K or C ΔT = 1.8 F ΔT

Step 3. Determine the exposed surface area of the cabinet in square feet.

Use the following formula to determine area when H, W and D are the cabinet dimensions in inches.

$$2[(H \times W) + (H \times D) + (W \times D)] \div 144 = \text{Area (ft.}^2\text{)}$$

Conversion: If dimensions are in millimeters, substitute 1,000,000 for 144. Then multiply the result by 10.76 to convert from m² to ft.²

Step 4. Determine the air conditioner capacity required

Use the following formula:

$$(\text{Watts} \times 3.413) + [(1.25 \times \text{Area in ft.}^2) \times \Delta T \text{ in F}] = \text{BTU/hr.}$$

Required air conditioner capacity in BTU/hr.

Use this formula to determine the required cooling capacity needed to maintain the desired operating temperature for your enclosure. This selection procedure applies to uninsulated, sealed, gasketed enclosures in indoor locations.

All industrial air conditioners are rated at their maximum operating point. Operating an air conditioner at temperatures below maximum conditions will result in reduced cooling capacity. In other words, operating 95 F ambient and 95 F enclosure temperature results in a 10 percent to 20 percent reduction in the rated capacity.

Full cooling capacity is probably not necessary at lower ambient temperatures.

Air Conditioners Sizing and Selection

SPECTRACOOL™ Air Conditioners



Height	BTU/Hr.	Watts
28 in.	4000	1100
28 in.	6000	1700
52 in.	8,000	2344
52 in.	12000	3721
57 in.	20000	5861

Type 4, 12, 3R T4 Line Indoor/Outdoor Air Conditioners



T4 Line	Height in./mm	Width in./mm	Depth in./mm	BTU/Hr.	Watts
T15	15.75	7.50	6.30	800	234
	400	191	160		
T20	20.00	10.00	9.90	2000	586
	508	254	251		
T29	29.00	17.00	11.30	4000	1172
	737	432	287		
T43	43.00	15.75	10.99	6680-8600	1958-2520
	1092	400	279		
T50	50.00	19.00	11.05	13,100	3838
	1270	483	281		
T53	52.85	20.85	13.00	20,000	5860
	1342	530	330		

Type 12 Side-Mount Subcompact Air Conditioners



Series	Height in./mm	Width in./mm	Depth in./mm	BTU/Hr.	Watts
T15	15.75	7.50	6.30	800	234
	400	191	160		

Air Conditioners Sizing and Selection

Type 12 GENESIS™ Side-Mount Compact Air Conditioners



Series	Height in./mm	Width in./mm	Depth in./mm	BTU/Hr.	Watts
13	13.25	14.25	7.80	1000	293
	337	362	198		
17	17.65	12.00	8.68	1800	527
	448	305	220		

Type 12 GENESIS™ Side-Mount Mid-Size Air Conditioners



Series	Height in./mm	Width in./mm	Depth in./mm	BTU/Hr.	Watts
28	28.50	17.00	11.33	2200-4000	586-1172
	724	432	288		
33NSM	34.37	12.00	9.88	4000	1172
	873	305	251		
36	38.72	15.00	11.33	6000-4300	1758
	984	381	288		

Air Conditioners Sizing and Selection

Type 12 GENESIS™ 3-Phase 460-Volt Side-Mount Full-Size Air Conditioners



Series	Height in./mm	Width in./mm	Depth in./mm	BTU/Hr.	Watts
52	52.63	17.13	11.33	3800-8000	1113-2344
	1337	435	288		
52	52.63	17.13	13.33	10,000	2930
	1337	435	339		

Type 12 GENESIS™ Top-Mount Air Conditioners



Series	Height in./mm	Width in./mm	Depth in./mm	BTU/Hr.	Watts
HBII	10.25	17.00	21.08	2200-4000	645-1172
	260	432	535		

Air Conditioners Sizing and Selection

Type 12, 3R CR Series Air Conditioners



Series	Height in./mm	Width in./mm	Depth in./mm	BTU/Hr.	Watts
CR23	23.00	10.00	8.75	1600	469
	584	254	222		
CR29	29.50	15.75	8.63	2200-4000	645-1172
	749	400	219		
CR43	43.31	15.75	10.25	6000-8000	1758-2490
	1100	400	260		

Type 4X CR Series Air Conditioners



Series	Height in./mm	Width in./mm	Depth in./mm	BTU/Hr.	Watts
CR23	23.00	10.00	8.75	1600	469
	584	254	222		
CR29	29.50	15.75	8.63	2200-4000	645-1172
	749	400	219		
CR43	43.31	15.75	10.25	6000-8000	1758-2490
	1100	400	260		

Type 12, 4, 4X VC Vortex Cooler



Series	Cooling Capacity (BTU/Hr.)	Cooling Capacity (W)	Voltage	Frequency (Hz)
VC04—	400	117	115	50/60
VC09—	900	264	115	50/60
VC15—	1500	440	115	50/60
VC17—	1700	498	115	50/60
VC25—	2500	733	115	50/60

Air Conditioners

SPECTRACOOL™ Air Conditioners - 4,000 and 6,000 BTU



- Exterior and partial recessed mounting options
- Attractive industrial design with minimal use of visible fasteners
- Reliable mechanical thermostat on enclosure side of the unit. Indoor Air Conditioner models include digital display on ambient side.
- Galvanized sheet-metal cover for rugged factory and outdoor environments
- Easy-mount flanges for simple installation
- Cut-out adapter options for enclosures with McLean GENESIS® and T-Series air conditioners, enabling users to easily transition to the new unit
- Dust-resistant condenser coil allows the unit to be run filterless in most applications
- Cleanable, reusable aluminum mesh filter to protect coils for maximum cooling performance
- Mounting hardware, gaskets and user manual furnished with the unit
- Every unit functionally tested before shipping
- Standard Indoor Air Conditioner models also include:
 - Active condensate management with heater strip
 - Power-off relay for door switch and other system requirements
 - Malfunction switch
- Standard Outdoor Air Conditioner models also include:
 - Telcordia GR-487 capable
 - Corrosion-resistant components
 - Malfunction switch
 - Compressor heater
 - Head pressure control
 - 2000 Watt enclosure heater

Industry Standards

UL/cUL Listed Type 12, 3R, 4

CE
 IP 56 Internal Loop
 IP 34 on External Loop
 Telcordia GR-487 capable (Outdoor)

Application

- Industrial automation
- Telecommunications equipment
- Waste water treatment systems
- Package handling equipment
- Security and defense systems
- And more

Features

- Energy efficient rotary compressor
- R407c and R134a earth-friendly refrigerants and RoHS compliant
- Models for 115, 230 and 400/460 3-phase AC volt power input
- UL Listed to save customers time and money with agency approvals
- Outdoor model operating temperature range from -40 F/-40 C to 131 F/55 C

Specifications

- Nominal cooling capacity 4000 & 6000 BTUs/Hr. (1172 and 1758 Watts)
- R407c earth-friendly refrigerant and RoHS compliant
- Outdoor model operating temperature range from -40 F/-40 C to 131 F/55 C

Finish

- RAL 7035 light-gray, semi-textured powder-coat paint
- Other colors and textures available

Notes

Visit www.McLeanCoolingTech.com to download 2D and 3D CAD drawings into the overall design of your electronic system.

Standard Product

Catalog Number	Ax B x C in./mm	Model Style	Rated Voltage	Frequency (Hz)	Phase	BTUs/Hr. at		Full Load Amps at 50/60 Hz	Max. Amb. Temp. (°F/°C)	Min. Amb. Temp. (°F/°C)	Starting Current (Amps)	Wt. (lb./kg)
						131 F/131 F (55 C/55 C)	95 F/95 F (35 C/35 C)					
G280416G050	28.55 x 16.97 x 10.10 725 x 431 x 257	Indoor	115	50/60	1	4600/4900	4300/4600	9.9/11.4	131/55	-40/-40	36.2	84/38
G280416G051	28.55 x 16.97 x 10.10 725 x 431 x 257	Indoor Stainless Steel Type 4X	115	50/60	1	4600/4900	4300/4600	9.9/11.4	131/55	-40/-40	36.2	84/38
G280416G100	28.55 x 16.97 x 10.10 725 x 431 x 257	Outdoor without Heat Pkg.	115	50/60	1	4600/4900	4300/4600	9.9/11.4	131/55	-40/-40	36.2	84/38
G280416G150	28.55 x 16.97 x 10.10 725 x 431 x 257	Outdoor with Heat Pkg.	115	50/60	1	4600/4900	4300/4600	9.9/11.4	131/55	-40/-40	36.2	84/38
G280426G050	28.55 x 16.97 x 10.10 725 x 431 x 257	Indoor	230	50/60	1	4600/4900	4300/4600	9.9/11.4	131/55	-40/-40	36.2	84/38
G280426G051	28.55 x 16.97 x 10.10 725 x 431 x 257	Indoor Stainless Steel Type 4X	230	50/60	1	4600/4900	4300/4600	4.6/5.8	131/55	-40/-40	17.7	84/38
G280426G100	28.55 x 16.97 x 10.10 725 x 431 x 257	Outdoor without Heat Pkg.	230	50/60	1	4600/4900	4300/4600	4.6/5.8	131/55	-40/-40	17.7	84/38
G280426G150	28.55 x 16.97 x 10.10 725 x 431 x 257	Outdoor with Heat Pkg.	230	50/60	1	4600/4900	4300/4600	4.6/5.8	131/55	-40/-40	17.7	84/38
G280446G050	28.55 x 16.97 x 10.10 725 x 431 x 257	Indoor	460	50/60	1	4600/4900	4300/4600	4.6/5.8	131/55	-40/-40	17.7	84/38

Air Conditioners

Catalog Number	AxBxC in./mm	Model Style	Rated Voltage	Frequency (Hz)	Phase	BTUs/Hr. at	BTUs/Hr. at	Full Load	Max. Amb. Temp. (°F/°C)	Min. Amb. Temp. (°F/°C)	Starting Current (Amps)	Wt. (lb./kg)
						131 F/131 F (55 C/55 C)	95 F/95 F (35 C/35 C)	Amps at 50/60 Hz				
G280446G051	28.55 x 16.97 x 10.10 725 x 431 x 257	Indoor Stainless Steel Type 4X	460	50/60	3~	4600/4900	4324/4655	1.3/1.4	131/55	-40/-40	7.7	84/38
G280446G100	28.55 x 16.97 x 10.10 725 x 431 x 257	Outdoor without Heat Pkg.	460	50/60	3~	4600/4900	4324/4655	1.3/1.4	131/55	-40/-40	7.7	84/38
G280616G050	28.55 x 16.97 x 10.10 725 x 431 x 257	Indoor	115	50/60	3~	4600/4900	4324/4655	1.3/1.4	131/55	-40/-40	7.7	84/38
G280616G051	28.55 x 16.97 x 10.10 725 x 431 x 257	Indoor Stainless Steel Type 4X	115	50/60	1	6000/6400	5600/6000	9.9/11.4	131/55	-40/-40	36.2	84/38
G280616G100	28.55 x 16.97 x 10.10 725 x 431 x 257	Outdoor without Heat Pkg.	115	50/60	1	6000/6400	5600/6000	9.9/11.4	131/55	-40/-40	36.2	84/38
G280616G150	28.55 x 16.97 x 10.10 725 x 431 x 257	Outdoor with Heat Pkg.	115	50/60	1	6000/6400	5600/6000	9.9/11.4	131/55	-40/-40	36.2	84/38
G280626G050	28.55 x 16.97 x 10.10 725 x 431 x 257	Indoor	230	50/60	1	6000/6400	5600/6000	9.9/11.4	131/55	-40/-40	36.2	84/38
G280626G051	28.55 x 16.97 x 10.10 725 x 431 x 257	Indoor Stainless Steel Type 4X	230	50/60	1	6000/6400	5600/6000	4.6/5.8	131/55	-40/-40	17.7	84/38
G280626G100	28.55 x 16.97 x 10.10 725 x 431 x 257	Outdoor without Heat Pkg.	230	50/60	1	6000/6400	5600/6000	4.6/5.8	131/55	-40/-40	17.7	84/38
G280626G150	28.55 x 16.97 x 10.10 725 x 431 x 257	Outdoor with Heat Pkg.	230	50/60	1	6000/6400	5600/6000	4.6/5.8	131/55	-40/-40	17.7	84/38
G280646G050	28.55 x 16.97 x 10.10 725 x 431 x 257	Indoor	460	50/60	1	6000/6400	5600/6000	4.6/5.8	131/55	-40/-40	17.7	84/38
G280646G051	28.55 x 16.97 x 10.10 725 x 431 x 257	Indoor Stainless Steel Type 4X	460	50/60	3~	5400/6000	5054/5685	1.3/1.4	131/55	-40/-40	7.7	84/38
G280646G100	28.55 x 16.97 x 10.10 725 x 431 x 257	Outdoor without Heat Pkg.	460	50/60	3~	5400/6000	5054/5685	1.3/1.4	131/55	-40/-40	7.7	84/38

Indoor Cutout Adapter, part number 28621601, enables SPECTRACOOL to be mounted to a GENESIS M28 Air Conditioner cutout.

Outdoor Cutout Adapter, part number 28621603, enables SPECTRACOOL to be mounted to a T-Series T29 Air Conditioner cutout.

460 V, 3-phase units use R134a refrigerant

Air Conditioners

SPECTRACOOL™ Air Conditioners - 8,000 and 12,000 BTU



- UL Listed to save customers time and money with agency approvals
- Outdoor model operating temperature range from -40 F/-40 C to 131 F/55 C
- Exterior and partial recessed mounting options
- Attractive industrial design with minimal use of visible fasteners
- Reliable mechanical thermostat on enclosure side of the unit. Indoor Air Conditioner models include digital display on ambient side.
- Dual condenser-side air movers for performance redundancy
- Galvanized sheet-metal cover for rugged factory and outdoor environments
- Easy-mount flanges for simple installation
- Cut-out adapter options for enclosures with McLean GENESIS® and T-Series air conditioners, enabling users to easily transition to the new unit
- Cleanable, reusable aluminum mesh filter to protect coils for maximum cooling performance
- Mounting hardware, gaskets and user manual furnished with the unit
- Every unit functionally tested before shipping
- Standard Indoor Air Conditioner models also include:
 - Active condensate management with heater strip
 - Power-off relay for door switch and other system requirements
 - Malfunction switch
- Standard Outdoor Air Conditioner models also include:
 - Telcordia GR-487 capable
 - Corrosion-resistant components
 - Malfunction switch
 - Compressor heater
 - Head pressure control
 - 2000 Watt enclosure heater

Industry Standards

UL/cUL Listed Type 12, 3R, 4

CE
 IP 56 Internal Loop
 IP 34 on External Loop
 Telcordia GR-487 capable (Outdoor)

Application

- Industrial automation
- Telecommunications equipment
- Waste water treatment systems
- Package handling equipment
- Security and defense systems
- And more

Features

- Energy efficient rotary compressor
- R134a earth-friendly refrigerant and RoHS compliant
- Models for 115, 230 and 400/460 3-phase AC volt power input

Specifications

- Nominal cooling capacity 8000 & 12000 BTUs/Hr. (2300 and 3500 Watts)
- R134a earth-friendly refrigerant and RoHS compliant
- Outdoor model operating temperature range from -40 F/-40 C to 131 F/55 C

Finish

- RAL 7035 light-gray, semi-textured powder-coat paint
- Other colors and textures available

Bulletin: MCL

Standard Product G52 Series

Catalog Number	AxBxC in./mm	Voltage	Hz	Phase	BTU/Hr. at Max. Ambient Temp.	Nominal Watts	BTU/Hr. at 131 F/131 F (55 C/55 C)	BTU/Hr. at 95 F/95 F (35 C/35 C)	Operating Temp. Range Max. (F/C)	Operating Temp Range Min. (F/C)	Ship Wt. (lb.)	Ship Wt. (kg)
G520816G050	52.69 x 17.12 x 11.66 1338 x 435 x 296	115	50/60	1	8000	2300	7300/8200	6000/6800	131/55	50/10	128	58.1
G520816G150	52.69 x 17.12 x 11.66 1338 x 435 x 296	115	50/60	1	8000	2300	7300/8200	6000/6800	131/55	50/10	128	58.1
G520826G050	52.69 x 17.12 x 11.66 1338 x 435 x 296	230	50/60	1	8000	2300	7300/8200	6000/6800	131/55	50/10	128	58.1
G520826G150	52.69 x 17.12 x 11.66 1338 x 435 x 296	230/208-230	50/60	1	8000	2300	7300/8200	6000/6800	131/55	50/10	128	58.1
G520846G050	52.69 x 17.12 x 11.66 1338 x 435 x 296	400/460 ~3	50/60	3	8000	2300	8800/9800	6000/6800	131/55	50/10	138	62.6
G521216G050	52.69 x 17.12 x 11.66 1338 x 435 x 296	115	50/60	1	12000	3500	12000/12500	9900/10700	131/55	50/10	131	59.4
G521216G150	52.69 x 17.12 x 11.66 1338 x 435 x 296	115	50/60	1	12000	3500	12000/12500	9900/10700	131/55	50/10	131	59.4
G521226G050	52.69 x 17.12 x 11.66 1338 x 435 x 296	230/208-230	50/60	1	12000	3500	12000/12500	9900/10700	131/55	50/10	131	59.4
G521226G150	52.69 x 17.12 x 11.66 1338 x 435 x 296	230/208-230	50/60	1	12000	3500	12000/12500	9900/10700	131/55	50/10	131	59.4
G521246G050	52.69 x 17.12 x 11.66 1338 x 435 x 296	400/460 ~3	50/60	3	12000	3500	11100/12000	9900/10700	131/55	50/10	141	64.0

Air Conditioners

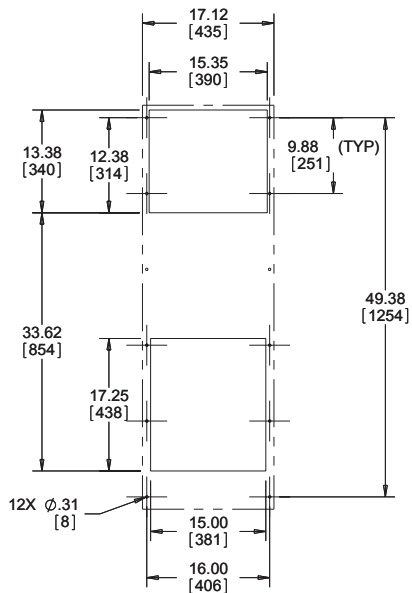
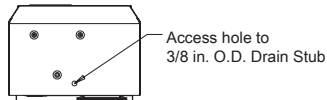
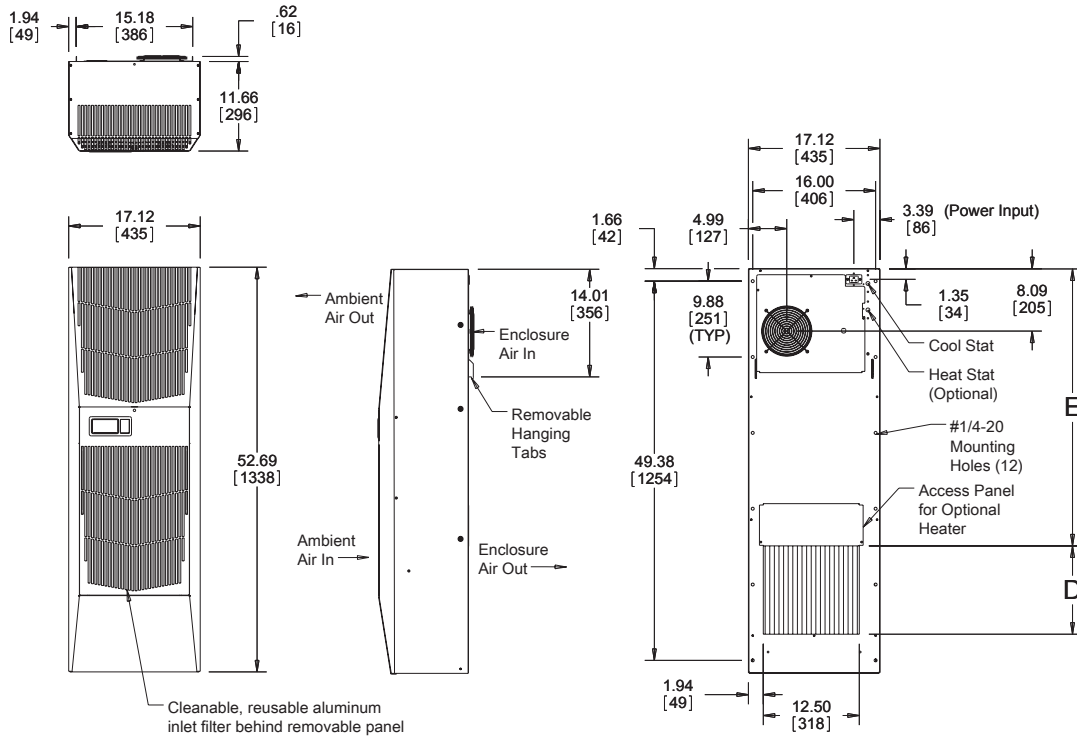

Mounting Cutout Dimensions (Standard)

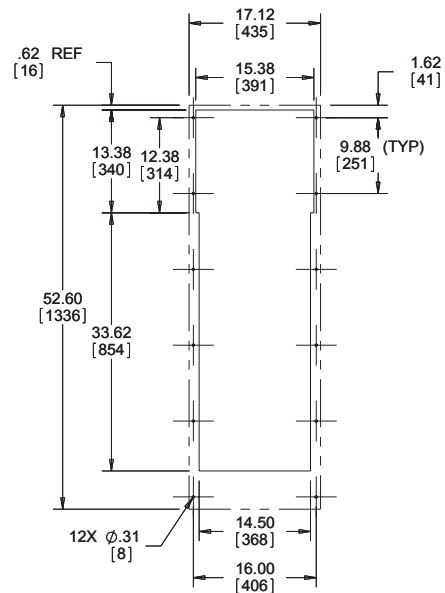

Mounting Cutout Dimensions (G520846G150, G521246G150 Only)

87957642

Air Conditioners

Cutout Adapter

Catalog Number	AxBxC in./mm	Description	Material	Ship Wt. (lb.)	Ship Wt. (kg)
52621601	0.00	M52 to G52 Cut-out Adapter	18 gauge galvanized	10	4.5

Cutout Adapter M52 to G52 Air Conditioner

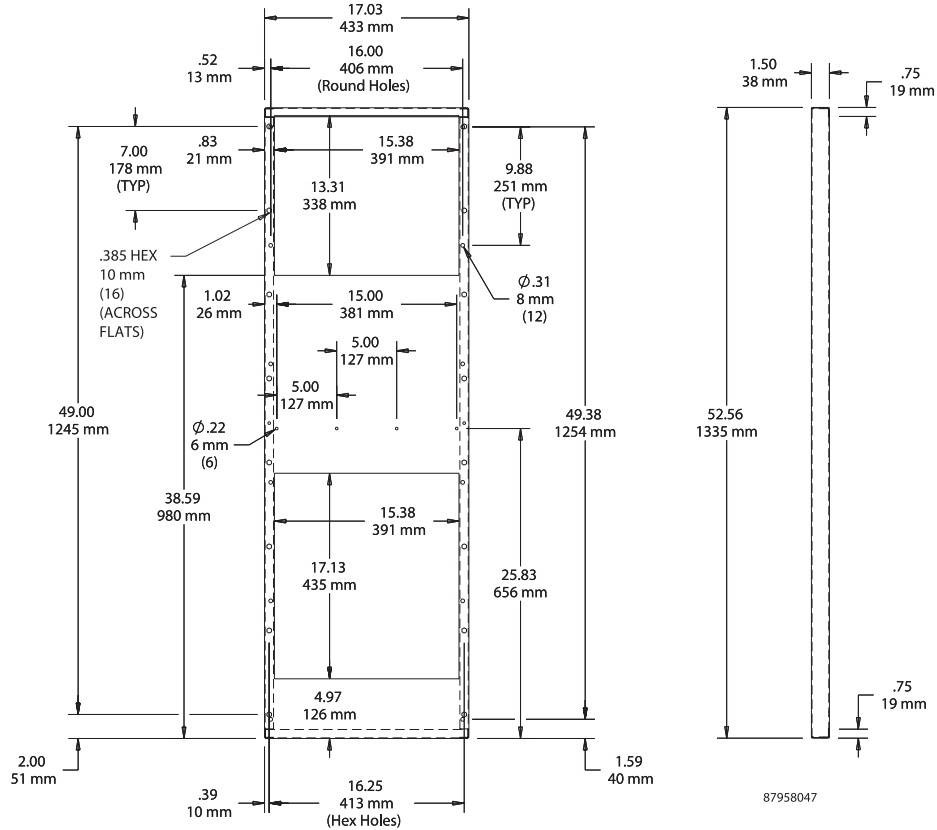
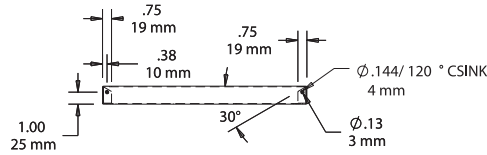



Air Conditioners

Notes

Air Conditioners

SPECTRACOOL™ Air Conditioners - 20,000 BTU



G57 Indoor Model
20000 BTU/Hr.
5900 Watts



G57 Outdoor Model
20000 BTU/Hr.
5900 Watts

Features

- Energy efficient rotary compressor
- R134a earth-friendly refrigerant and RoHS compliant
- Models for 208, 230 and 400/460 3-phase AC volt power input
- UL Listed to save customers time and money with agency approvals
- Outdoor model operating temperature range from -40 F/-40 C to 131 F/55 C
- Exterior and partial recessed mounting options
- Attractive industrial design with minimal use of visible fasteners
- Reliable mechanical thermostat on enclosure side of the unit. Indoor Air Conditioner models include digital display on ambient side.
- Dual condenser-side air movers for performance redundancy
- Galvanized sheet-metal cover for rugged factory and outdoor environments
- Easy-mount flanges for simple installation
- Cut-out adapter options for enclosures with McLean T-Series air conditioners, enabling users to easily transition to the new unit
- Cleanable, reusable aluminum mesh filter to protect coils for maximum cooling performance
- Mounting hardware, gaskets and user manual furnished with the unit
- Every unit functionally tested before shipping
- Standard Indoor Air Conditioner models also include:
 - Active condensate management with heater strip
 - Power-off relay for door switch and other system requirements
 - Malfunction switch
- Standard Outdoor Air Conditioner models also include:
 - Telcordia GR-487 capable
 - Corrosion-resistant components
 - Malfunction switch
 - Compressor heater
 - Head pressure control
 - Maximum 3000 Watt enclosure heater (Not available on 400/460 V 3~ outdoor models)

Industry Standards

UL/cUL Listed Type 12, 3R, 4, 4X

CE
IP 56 Internal Loop
IP 34 on External Loop
Telcordia GR-487 capable (Outdoor)

Application

- Industrial automation
- Telecommunications equipment
- Waste water treatment systems
- Package handling equipment
- Security and defense systems
- And more

Specifications

- Nominal cooling capacity 20000 BTUs/Hr. (5900 Watts)
- R134a earth-friendly refrigerant and RoHS compliant
- Outdoor model operating temperature range from -40 F/-40 C to 131 F/55 C

Finish

- RAL 7035 light-gray, semi-textured powder-coat paint
- Other colors and textures available

Bulletin: MCL

Standard Product

Catalog Number	AxBxC in./mm	Voltage	BTU/Hr. at Max. Ambient Temp.	Nominal Watts	BTU/Hr. at 131 F/131 F (55 C/55 C)	BTU/Hr. at 95 F/95 F (35 C/35 C)	Operating Temp. Range Max. (F/C)	Shipping Weight (lb.)	Shipping Weight (kg)
G572026G100	57.69 x 20.78 x 15.29 1465 x 528 x 388	230	20000	5861	17500/19600	16000/18000	131/55	197	89
G572026G050	57.69 x 20.87 x 15.28 1465 x 530 x 388	230	20000	5861	17500/19600	16000/18000	131/55	197	89
G572026G150	57.69 x 20.87 x 15.28 1465 x 530 x 388	230	20000	5861	17500/19600	16000/18000	131/55	197	89
G572046G050	57.69 x 20.87 x 15.28 1465 x 530 x 388	400/460 3~	20000	5861	21400/23400	19300/21400	131/55	197	89
G572046G150	57.69 x 20.87 x 15.28 1465 x 530 x 388	400/460 3~	20000	5861	21400/23400	19300/21400	131/55	197	89

Air Conditioners

20,000 BTU/Hr., 230V

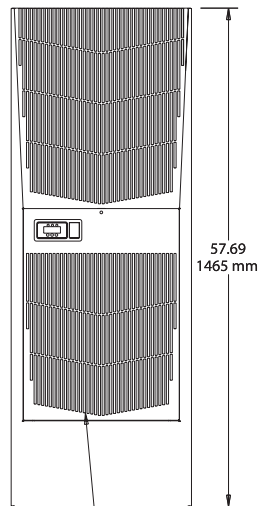
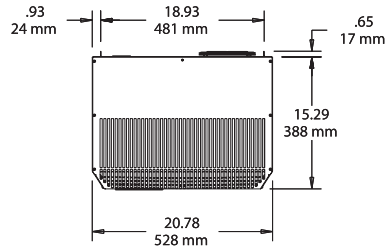

Cleanable, reusable aluminum inlet filter behind removable panel

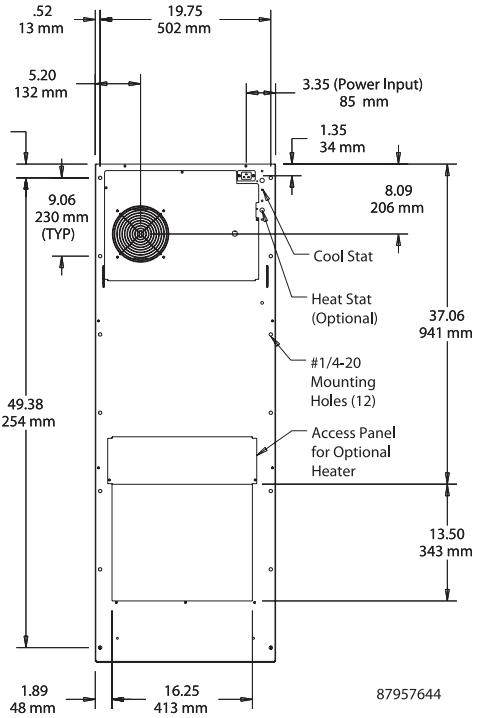
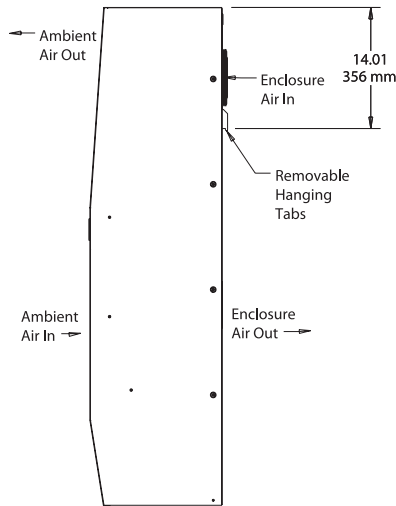

87957644

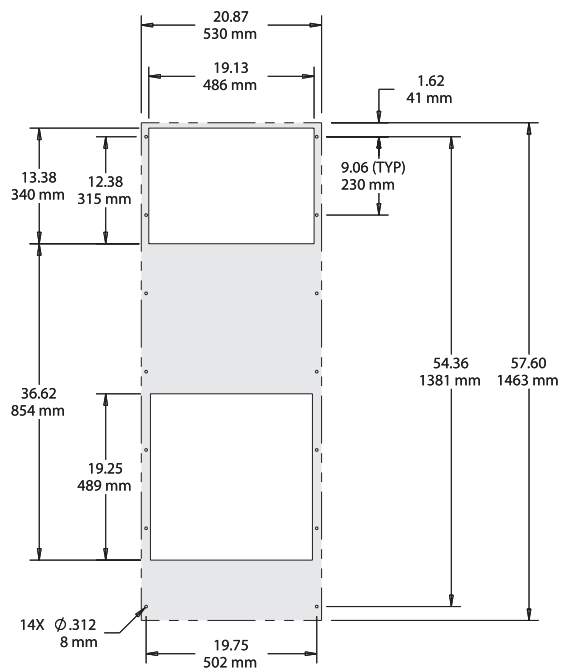
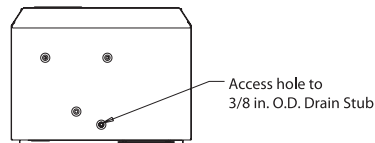

Mounting Cutout Dimensions

Air Conditioners

Outdoor Air Conditioners T15, T20 and T29 Series 800-4,000 BTU/Hr.



Application

Outdoor Air Conditioners provide high-efficiency positive cooling for wall-mount and stand-alone enclosures. Designed for outdoor applications requiring up to UL Type 4 rating.

Features

- Equipped with head pressure control for low ambient operation, compressor heater, coated condenser coil and thermostat
- Surface and internal recess mounting capabilities
- Equipped with a screwdriver-adjustable thermostat
- EMI/RFI noise suppressor is standard
- Reusable and washable air filter
- Broad operating range of -40 F (-40 C) to 131 F (55 C)
- All units use a CFC-free refrigerant
- Includes power cord with plug
- Built-in hanging brackets
- High performance, industrial grade and efficiency fans
- Hardware, gasket and instruction manual furnished
- Closed-loop cooling

Specifications

Galvanized steel

Finish

RAL 7035 smooth light-gray polyester powder coating

Bulletin: MCL

Industry Standards

Maintain UL/cUL Type 12, 3R or 4 rating when properly installed on a UL/cUL Type 12, 3R or 4 rated enclosure.

UL/cUL Listed; File No. SA6453

CE

Standard Product T15 Series

Catalog Number	Voltage	Hz	Phase	BTU/Hr. @ Max.	Full Load	50 Hz Max.	50 Hz Max.	60 Hz Max.	60 Hz Max.	Ship	Ship
				Ambient Temp.	Amps	Amb. Temp. (°F)	Amb. Temp. (°C)	Amb. Temp. (°F)	Amb. Temp. (°C)	Wt. (lb.)	Wt. (kg)
T150116G100	100/115	50/60	1	800/800	3.8/3.6	125	52	131	55	27	12
T150126G100	220/230	50/60	1	800/900	1.4/1.5	125	52	131	55	27	21

Replacement Filter No. 10100091

Standard Product T20 Series

Catalog Number	Voltage	Hz	Phase	BTU/Hr. @ Max.	Full Load	60 Hz Max.	60 Hz Max.	Ship	Ship
				Ambient Temp.	Amps	Amb. Temp. (°F)	Amb. Temp. (°C)	Wt. (lb.)	Wt. (kg)
T200216G100	115	50/60	1	1800/2000	7	131	55	56	25
T200226G100	230	50/60	1	1800/2000	3.5	131	55	56	25

Replacement Filter No. 10100090

Standard Product T29 Series

Catalog Number	Voltage	Hz	Phase	BTU/Hr. @ Max.	Full Load	60 Hz Max.	6 Hz Max.	Ship	Ship
				Ambient Temp.	Amps	Amb. Temp. (°F)	Amb. Temp. (°C)	Wt. (lb.)	Wt. (kg)
T290416G100	115	50/60	1	3600/4000	13.8/13.6	131	55	107	49
T290426G100	230	50/60	1	3600/4000	6.9/6.8	131	55	107	49

Replacement Filter No. 10100093

Air Conditioners

800 BTU

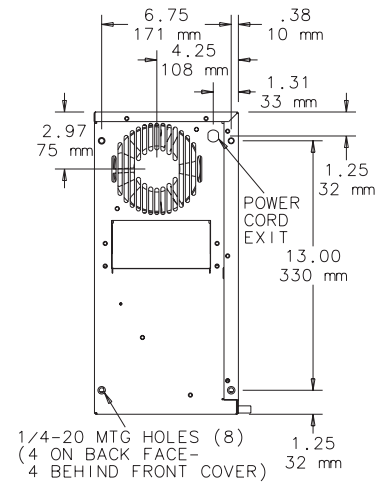
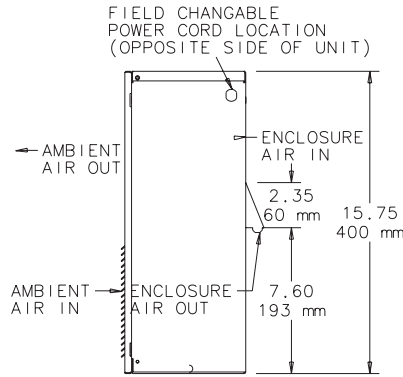
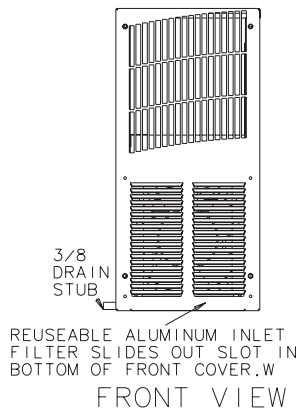

87939674

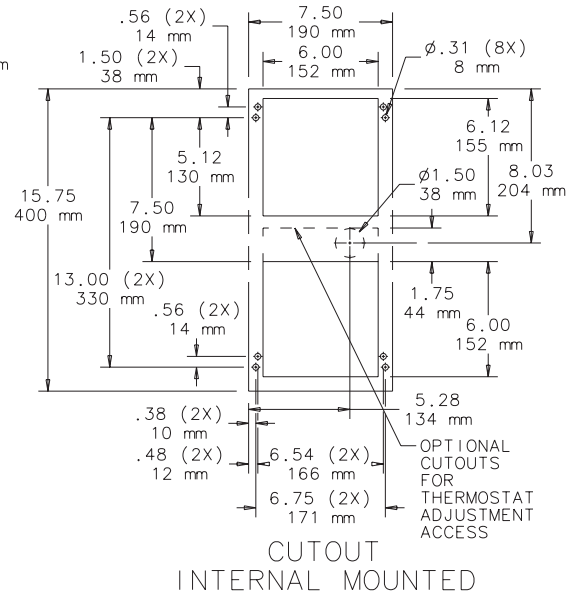
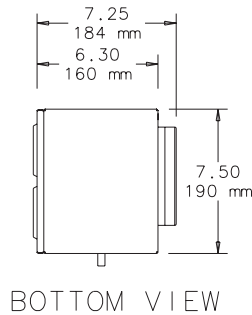
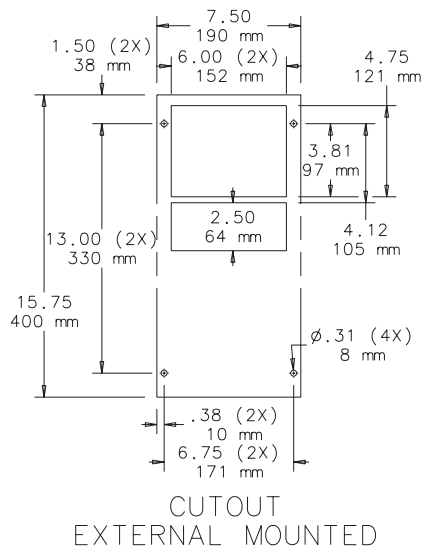

T15-0126-Gxxx Capacity Curves 230V 60Hz

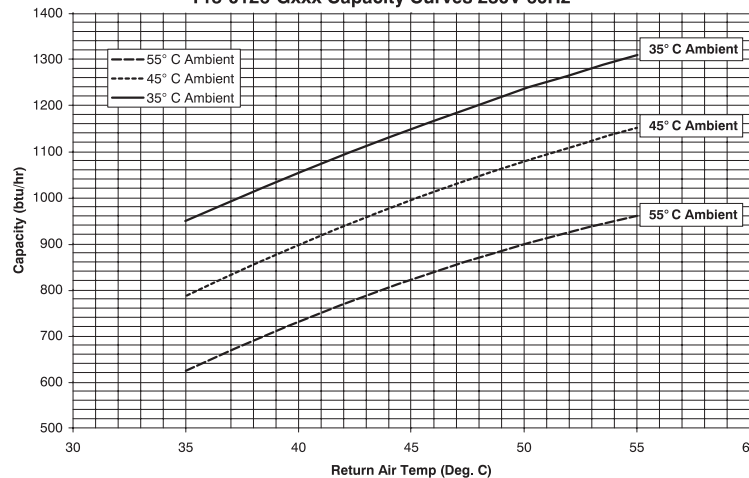

Air Conditioners

2000 BTU

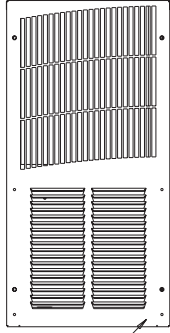

REUSABLE ALUMINUM INLET FILTER SLIDES OUT SLOT IN BOTTOM OF FRONT COVER.

FRONT

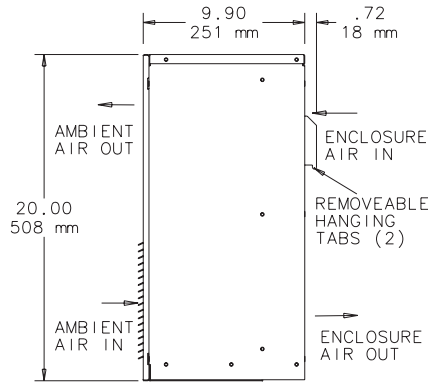

RIGHT

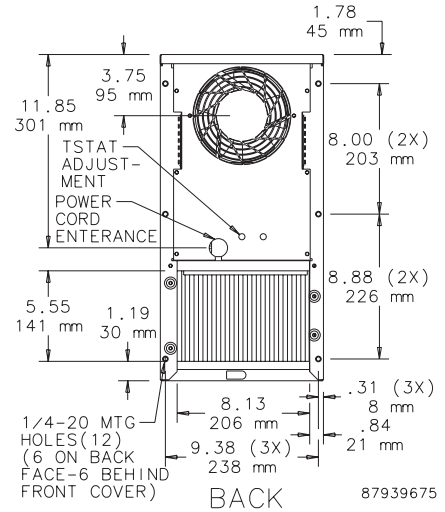

BACK

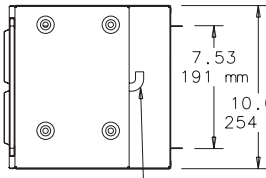

BOTTOM

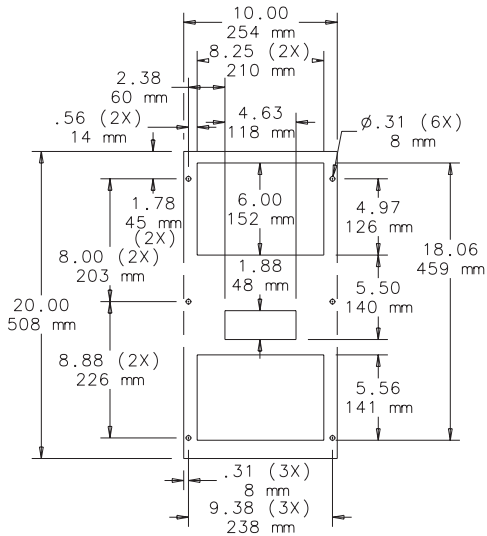

CUTOUT EXTERNAL MOUNTED

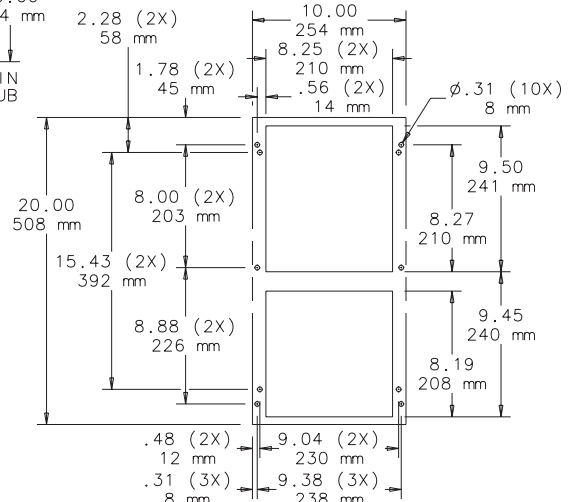

CUTOUT INTERNAL MOUNTED

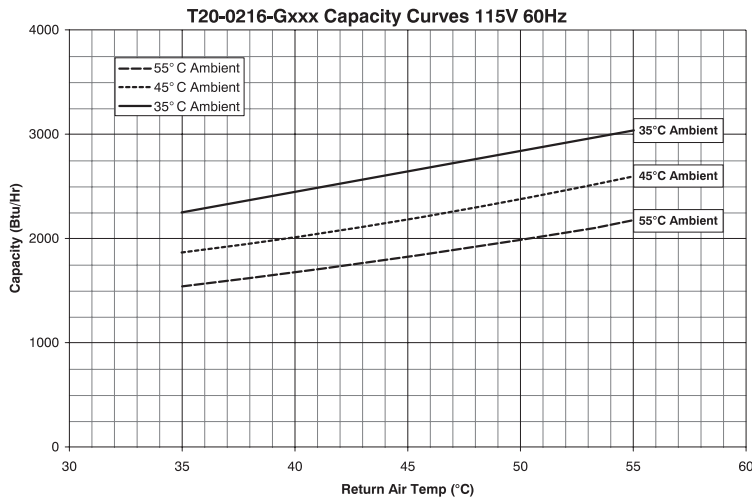

Air Conditioners

4000 BTU

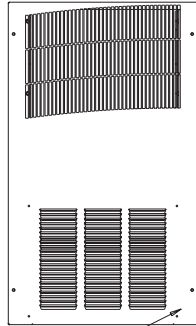

REUSEABLE ALUMINUM INLET FILTER SLIDES OUT SLOT IN BOTTOM OF FRONT COVER.

FRONT

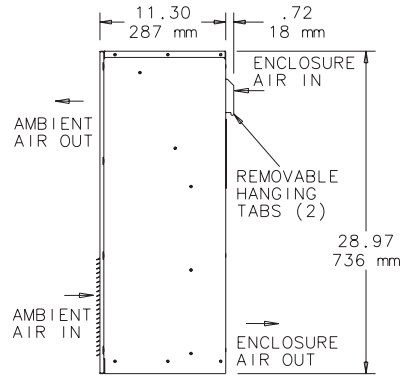

RIGHT

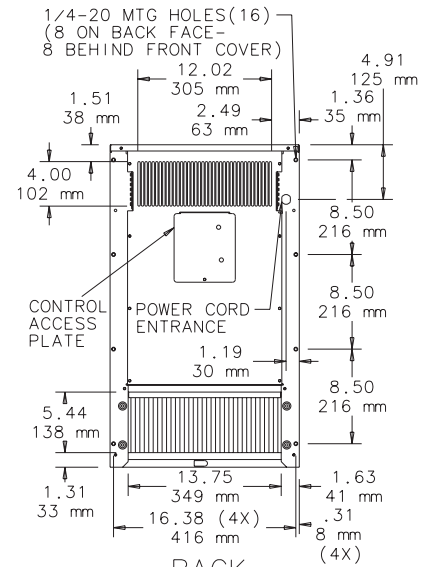

BACK

87939676

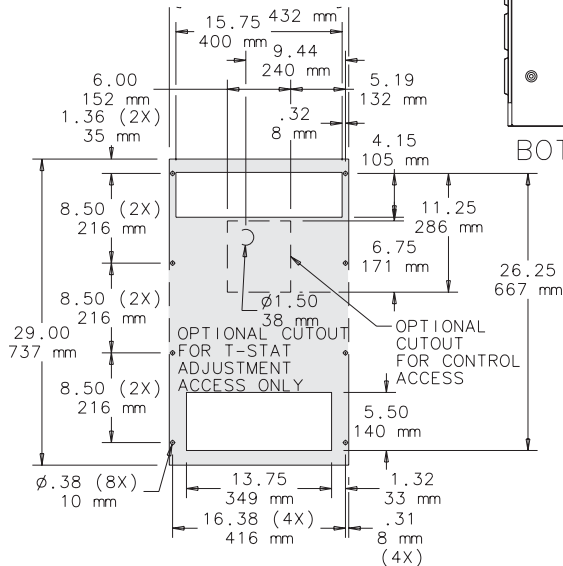

CUTOUT EXTERNAL MOUNTED

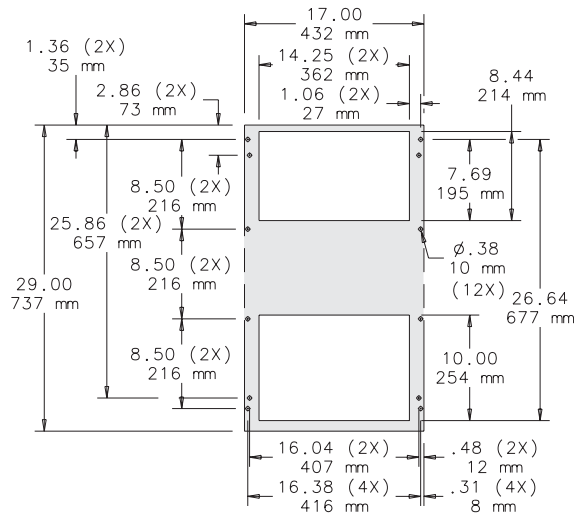

CUTOUT INTERNAL MOUNTED

T29-04x6-Gxxx Capacity Curves, 60 Hz

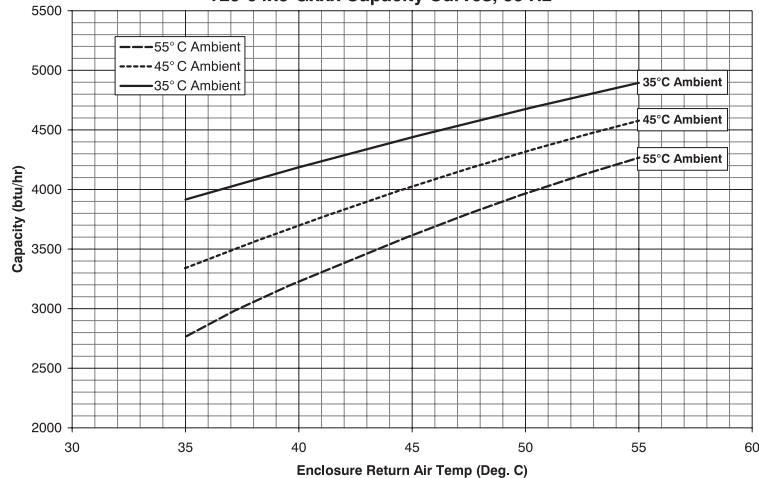

Air Conditioners

Outdoor Air Conditioners T43, T50 and T53 Series 6,680-20,000 BTU/Hr.



Features

- Equipped with head pressure control for low ambient operation, compressor heater, coated condenser coil and thermostat
- Surface and internal recess mounting capabilities
- Equipped with a screwdriver-adjustable thermostat
- EMI/RFI noise suppressor is standard
- Reusable and washable air filter
- Broad operating range of -40 F (-40 C) to 131 F (55 C)
- Includes power cord with plug
- Built-in hanging brackets
- High performance, industrial grade and efficiency fans
- Hardware, gasket and instruction manual furnished
- In accordance with the Montreal Protocol, the T53 GENESIS™ Air Conditioners have transitioned away from R22 refrigerant. Product performance remains within nominal capacity.

Industry Standards

Galvanized versions maintain UL/cUL Type 12, 3R or 4 rating when properly installed on UL/cUL Type 12, 3R or 4 rated enclosure. Stainless steel versions maintain UL/cUL Type 12, 3R or 4X rating when properly installed on UL/cUL Type 12, 3R or 4X rated enclosure.

UL/cUL Listed, UL File Number SA6453

CE

Application

Outdoor Air Conditioners provide high-efficiency positive cooling for wall-mount and stand-alone enclosures. Designed for outdoor applications requiring up to UL Type 4X rating.

Specifications

- Galvanized steel
- Stainless steel

Accessories

Replacement filter

Bulletin: MCL

Standard Product T43 Series

Catalog Number	Voltage	Hz	Phase	Material	BTU/Hr. @ Max. Ambient Temp.	Full Load Amps	60 Hz Max. Amb. Temp. (°F)	60 Hz Max. Amb. Temp. (°C)	Ship Wt. (lb.)	Ship Wt. (kg)
T430616G100	115	50/60	1	Galvanized	6310/6680	9.2/8.6	131	55	125	57
T430626G100	230	50/60	1	Galvanized	6520/6770	4.4/3.8	131	55	125	57
T430816G100	115	50/60	1	Galvanized	7900/8600	10.4/11.2	131	55	125	57
T430826G100	230	50/60	1	Galvanized	7400/8200	5.2/5.4	131	55	125	57
T431016G102	115	50/60	1	Stainless Steel	9700/10,300	15.9/19.9	131	55	125	57
T431026G104	230	50/60	1	Stainless Steel	10,000/10,600	9.0/9.0	131	55	125	57

Replacement Filter No. 10100096

Standard Product T50 Series

Catalog Number	Voltage	Hz	Phase	Material	BTU/Hr. @ Max. Ambient Temp.	Full Load Amps	60 Hz Max. Amb. Temp. (°F)	60 Hz Max. Amb. Temp. (°C)	Ship Wt. (lb.)	Ship Wt. (kg)
T501226G100	230	50/60	1	Galvanized	11,000/12,000	8.2/9.3	131	55	164	75
T501226G125	230	50/60	1	Stainless Steel	11,000/12,000	8.2/9.3	131	55	164	75

Replacement Filter No. 10100083

Standard Product T53 Series

Catalog Number	Voltage	Hz	Phase	Material	BTU/Hr. @ Max. Ambient Temp.	Full Load Amps	60 Hz Max. Amb. Temp. (°F)	60 Hz Max. Amb. Temp. (°C)	Ship Wt. (lb.)	Ship Wt. (kg)
T531926G100	230	50/60	1	Galvanized	18,000 / 20,000	17.3 / 20.3	131	55	197	90

Replacement Filter No. 10100085

Air Conditioners

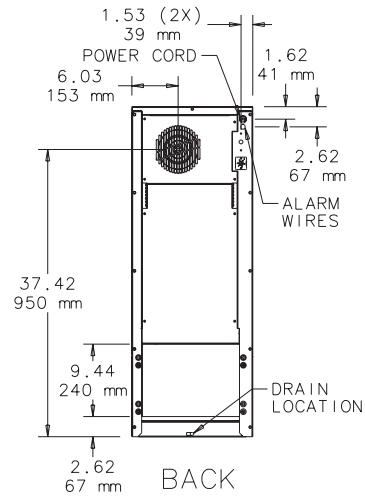
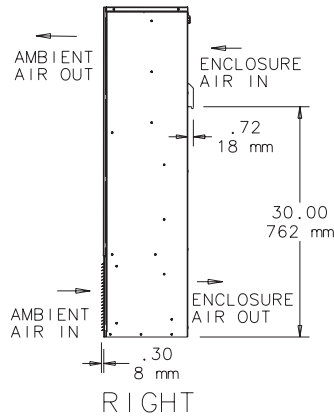
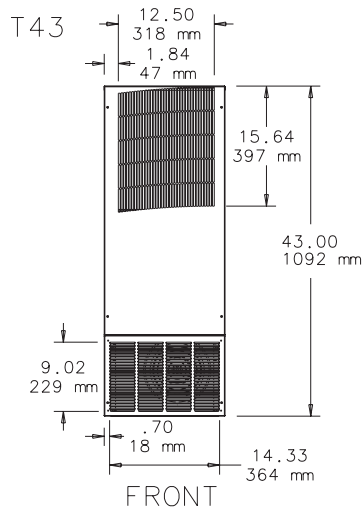

87939685

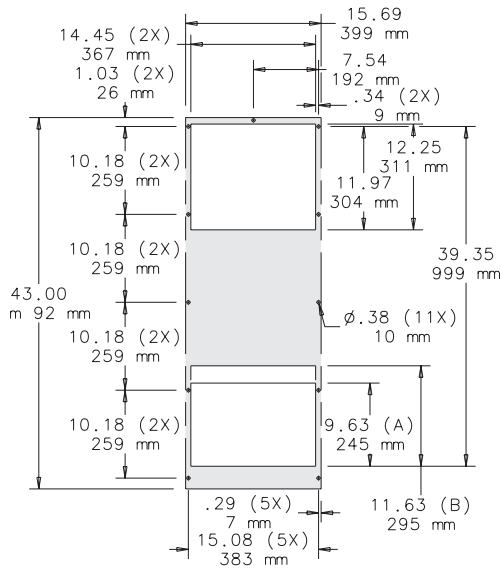

CUTOUT EXTERNAL MOUNTED

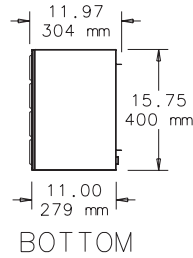

BOTTOM

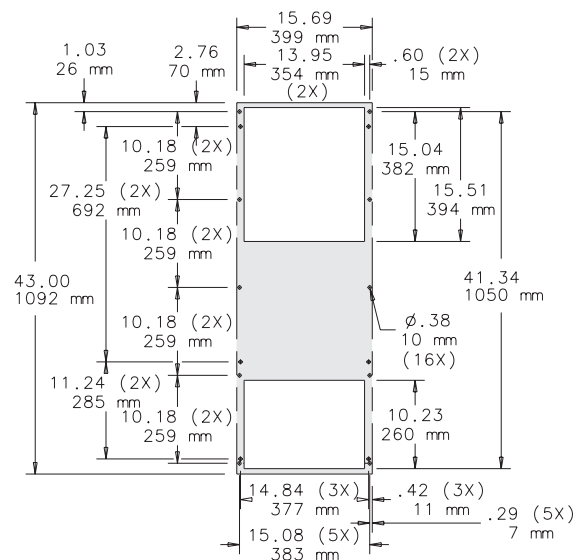

CUTOUT INTERNAL MOUNTED

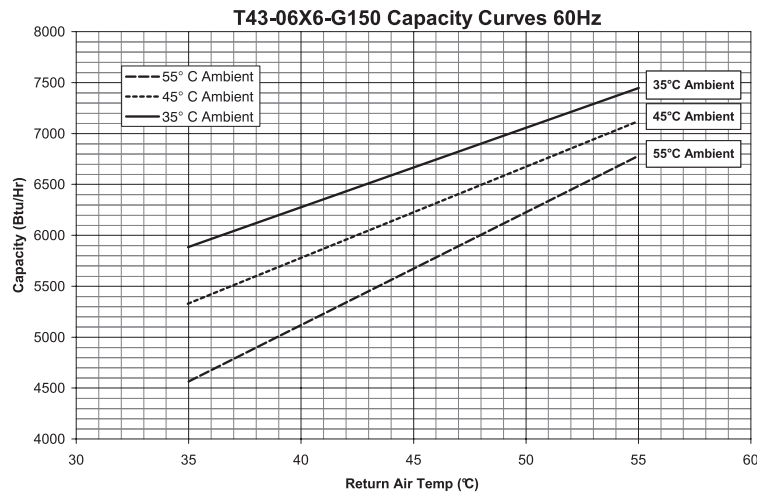

Air Conditioners

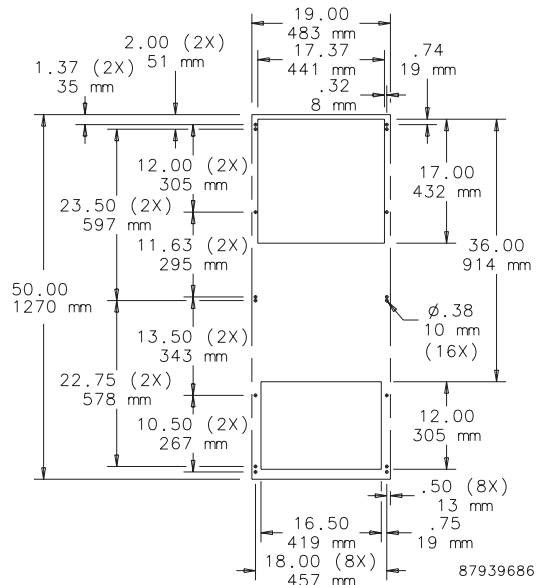
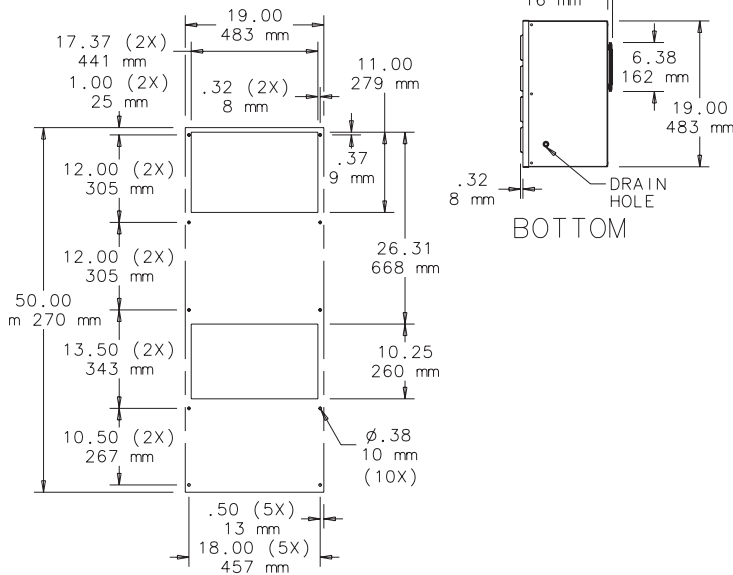
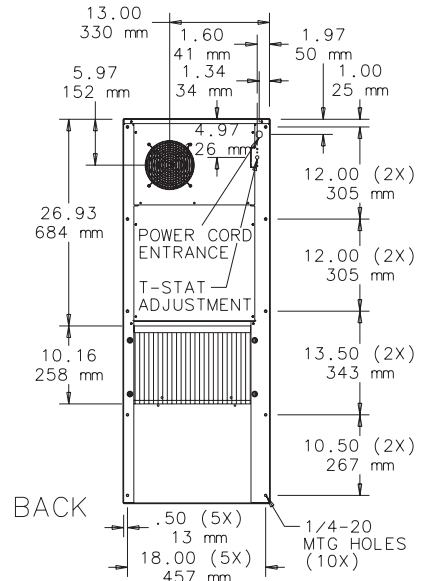
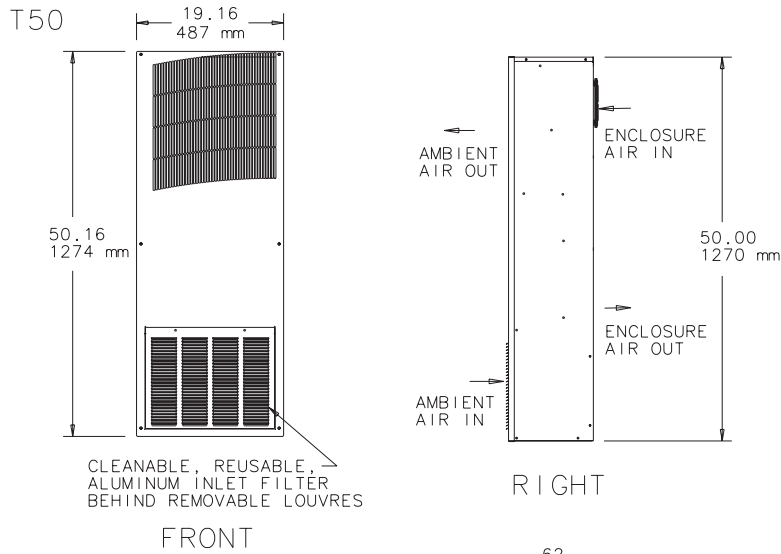

CUTOUT EXTERNAL MOUNTED

CUTOUT INTERNAL MOUNTED

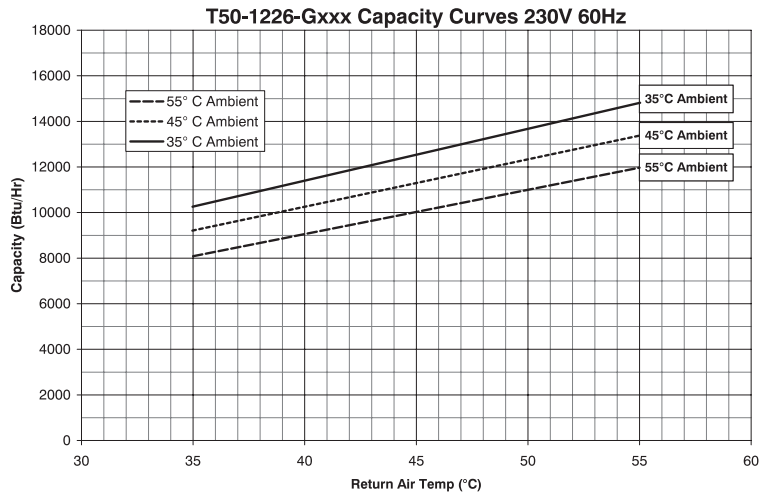

Air Conditioners

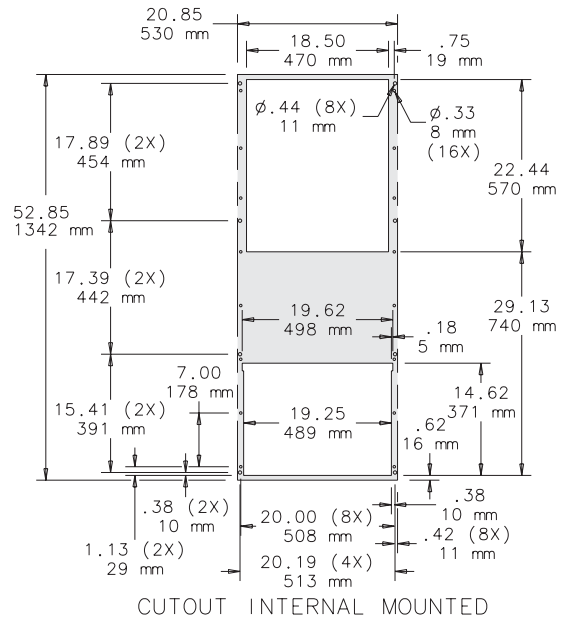
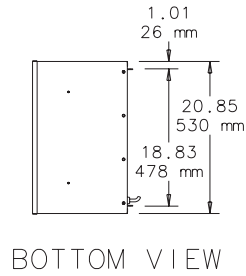
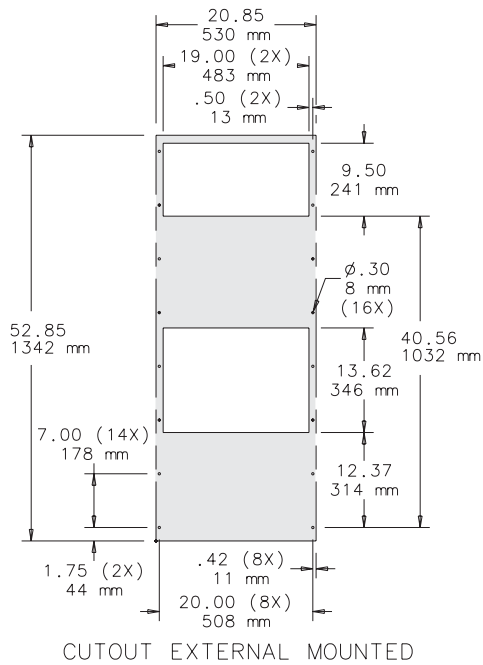
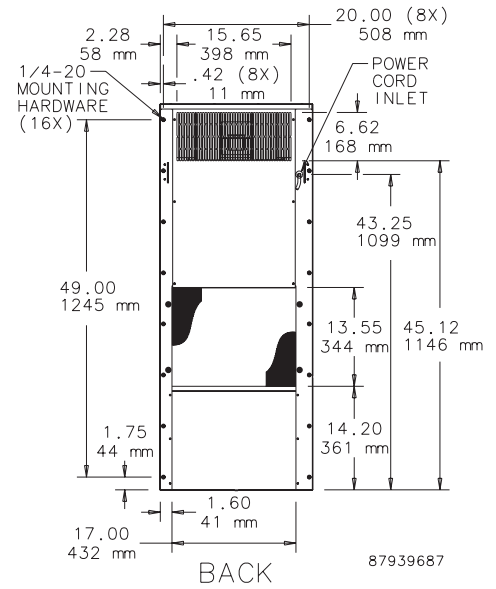
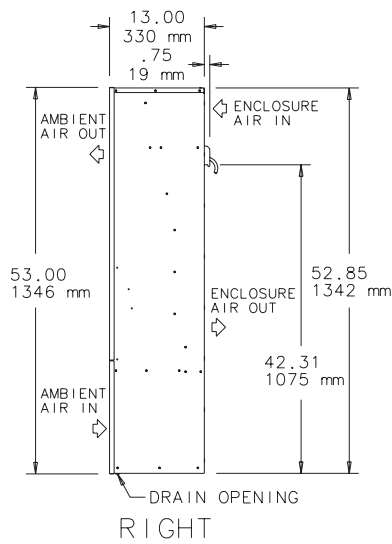
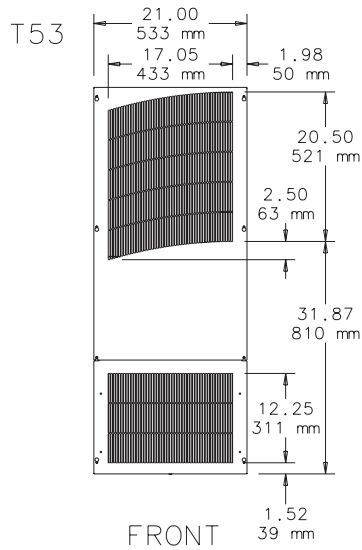

Air Conditioners

Performance Curves for T53 19000 BTU/Hr (5567 Watt) Models

T53-1926-GXXX Capacity Curve 50Hz
Return Air Temp (°C)

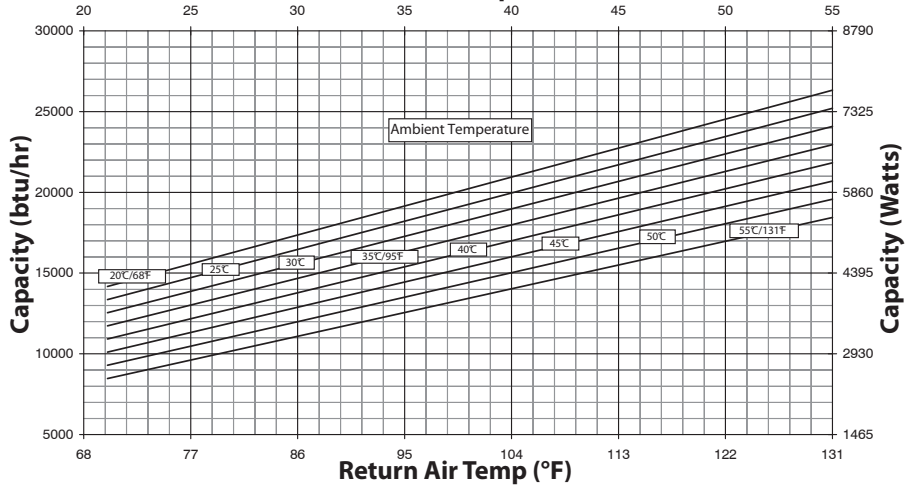

T53-1926-GXXX Capacity Curve 60Hz
Return Air Temp (°C)

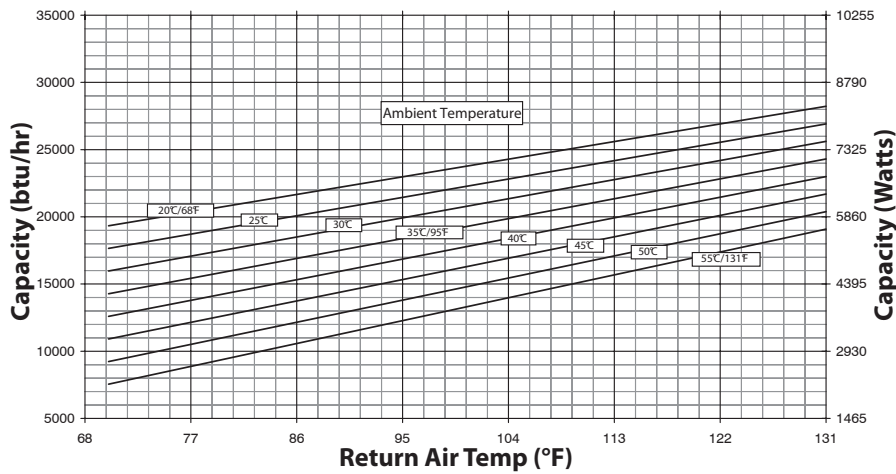



Air Conditioners

Notes

Air Conditioners

Side-Mount Subcompact Air Conditioner



Industry Standards

Maintains UL/cUL Type 12 or 3R rating when properly installed on a UL/cUL Type 12 or 3R enclosure.

UL/cUL Listed; File No. SA6453

CE

Application

In indoor industrial applications, the Side-Mount Subcompact Air Conditioner provides high-efficiency, positive cooling for densely-populated wall-mount and narrow enclosures that require a high degree of heat dissipation.

Features

- Equipped with a screwdriver-adjustable thermostat
- High-performance, industrial-grade ball-bearing fans
- Reusable and washable air filter
- Built-in hanging brackets
- EMI/RFI noise suppressor is standard
- Includes power cord with plug for standard grounded outlet
- Condensate management system with base pan side drain
- All units use a universally accepted CFC-free or environmentally safe refrigerant
- Mounting hardware, gaskets, mounting template and instruction manual furnished
- Closed-loop cooling

Finish

RAL 7035 light-gray polyester powder coating

Bulletin: MCL

Standard Product

Catalog Number	Voltage	Hz	Phase	BTU/Hr. @ Max. Ambient Temp.	Full Load Amps	50 Hz Max Amb. Temp. (°F)	50 Hz Max Amb. Temp. (°C)	60 Hz Max Amb. Temp. (°F)	60 Hz Max Amb. Temp. (°C)	Ship Wt. (lb.)	Ship Wt. (kg)
T150116G120	110/115	50/60	1	800	3.8/3.6	125	52	131	55	27	12.25
T150126G120	220/230	50/60	1	800	1.4/1.5	125	52	131	55	27	12.25

Replacement Filter No. 10100091

Air Conditioners

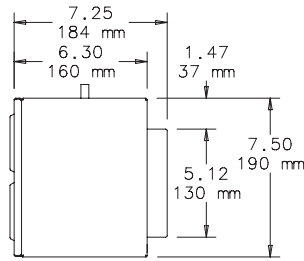

TOP VIEW

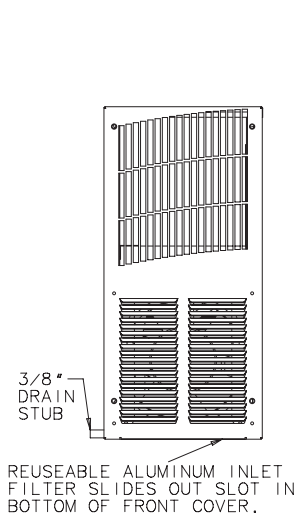

FRONT VIEW

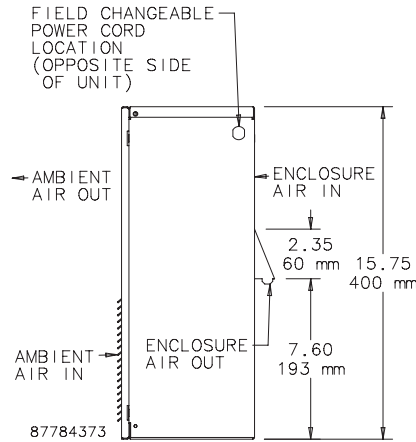

RIGHT VIEW

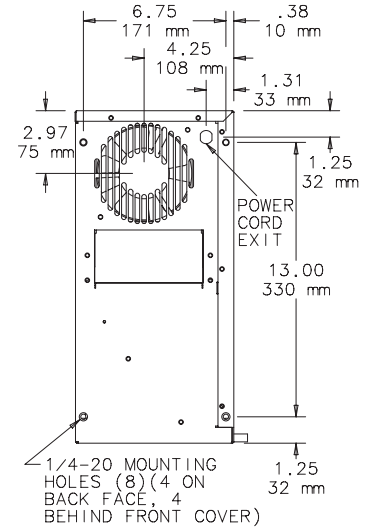

BACK VIEW

Notes:

1. Shaded area represents air conditioner.
2. Cutout dimensions for standard product only.
3. Full-size mounting template provided.

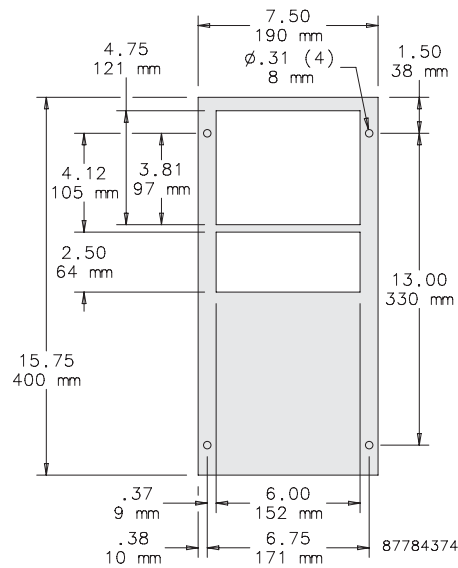

MOUNTING CUTOUT DIMENSIONS

Air Conditioners

GENESIS™ Side-Mount Compact Air Conditioner

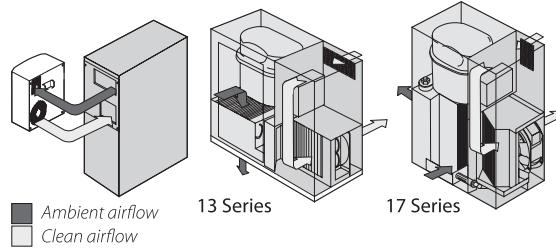

Industry Standards

Maintains U/CUL Type 12 rating when properly installed on a UL/cUL Type 12 enclosure.

UL/cUL Listed; File No. SA6453

CE

Application

13 Series and 17 Series compact air conditioners cool 25- to 40-cu. ft. enclosures in indoor applications.

Features

- High-performance, industrial-grade ball-bearing fans
- Removable air filter and grille
- Built-in hanging brackets
- All units use a universally accepted CFC-free or environmentally safe refrigerant
- Mounting hardware, gaskets, mounting template and instruction manual furnished
- Closed-loop cooling

Finish

- Body: RAL 7042 smooth gray polyester powder coating
- Grille: RAL 7035 light gray

Notes

Hoffman side-mount models are directly interchangeable with comparable Slimboy and GENESIS models.

Bulletin: MCL

Standard Product GENESIS Side-Mount 13 Series

Catalog Number	Voltage	Hz	Phase	BTU/Hr. @ 125 F/125 F	Full Load Amps	Max. Ambient Temp. (°F)	Max. Ambient Temp. (°C)	Ship Wt. (lb.)	Ship Wt. (kg)
M130116G1014	115	50/60	1	800/1000	4.0/4.0	125	52	48	22
M130126G1008	230	50/60	1	800/1000	2.2/2.1	125	52	48	22
M130146G1400	460	50/60	1	800/1000	1.2/1.2	125	52	58	26

Replacement filter No. 10100057

13 Series

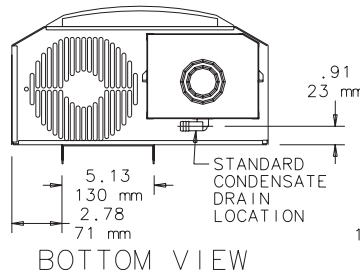
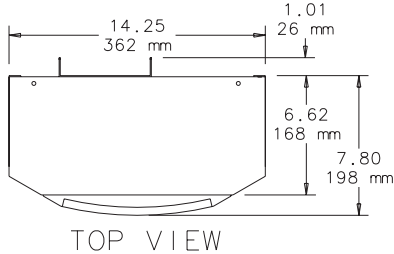

NOTE:
 1. Gasket for mounting to enclosure included.
 2. Service cord.
 Number in triangle in CAD view refers to note number.

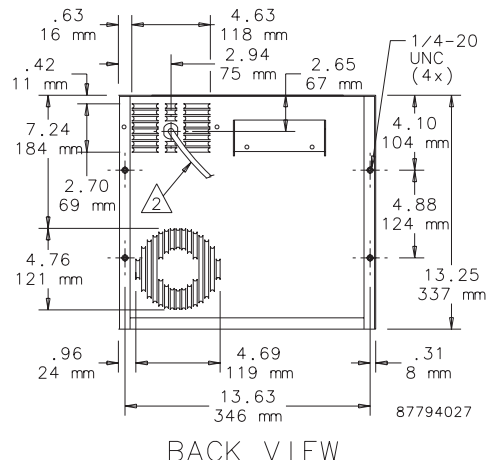
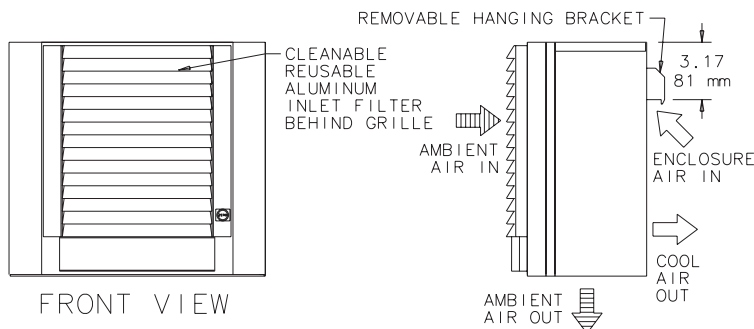

Air Conditioners

Standard Product GENESIS Side-Mount 17 Series

Catalog Number	Voltage	Hz	Phase	BTU/Hr. @ 125 F/125 F	Full Load Amps	Max. Amb. Temp. (°F)	Max. Amb. Temp. (°C)	Ship Wt. (lb.)	Ship Wt. (kg)
M170216G009	110/115	50/60	1	1500/1800	6.6/6.7	125	52	56	25
M170226G004	220/230	50/60	1	1500/1800	4.2/3.7	125	52	56	25
M170246G400	460	50/60	1	1500/1800	2.3/2.0	125	52	66	30

Replacement Filter No. 10100057

17 Series

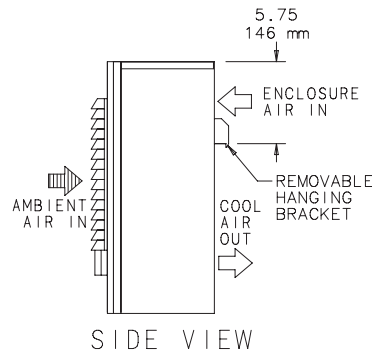
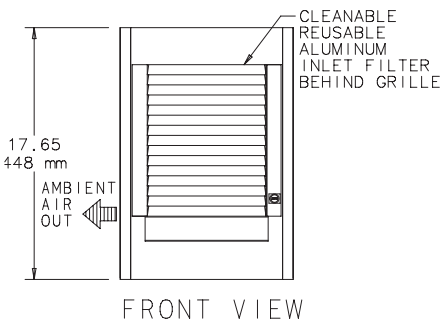
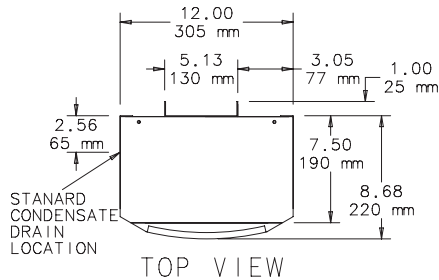

NOTE:

- Gasket kit for mounting to enclosure included.
- Service cord.
- Condensate from enclosure drains to bottom of unit, where it is evaporated by condenser heat.

Number in triangle in CAD view refers to note number.

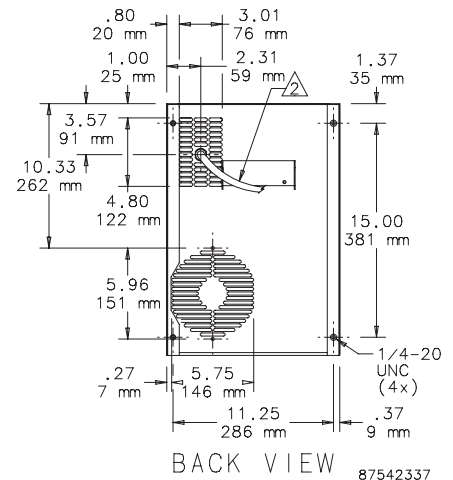

Cutout Dimensions

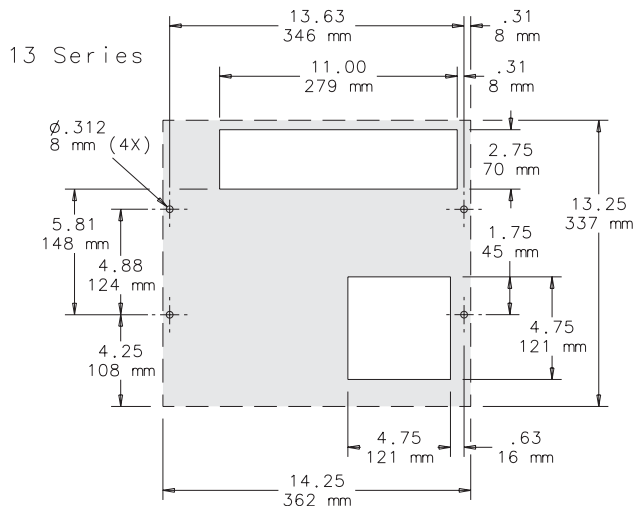

- NOTE:
- Shaded area represents air conditioner.
 - Cutout dimensions for standard products only.
 - Full-size mounting template provided.

17 Series

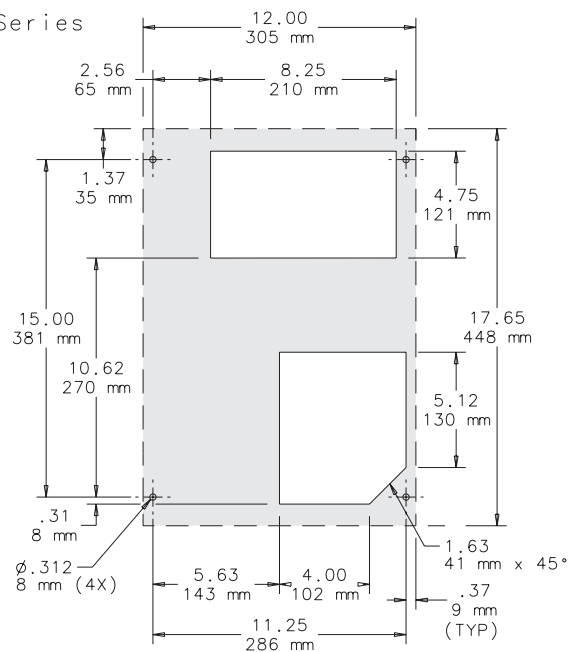

87939691

Air Conditioners

GENESIS™ Side-Mount Mid-Size Air Conditioner

**Industry Standards**

Maintains UL/cUL Type 12 rating when properly installed on a UL/cUL Type 12 enclosure.

UL/cUL Listed; UL File No. SA6453

CE

Application

Less than 12-in. deep, the 28 Series, 33NSM Series and 36N Series Air Conditioners offer a broad capacity range for applications requiring narrow enclosures.

Features

- Thermostat control
- High-performance, industrial-grade ball bearing fans in the 33 NSM and high performance centrifugal blowers in the 28 and 36N
- Removable air filter
- Built-in hanging brackets
- EMI/RFI noise suppressor is standard
- Unique condensate management system
- All units use a universally accepted CFC-free or environmentally-safe refrigerant
- Mounting gaskets and instruction manual furnished
- In accordance with the Montreal Protocol, the GENESIS™ 36 Series Air Conditioners have transitioned away from R22 refrigerant. Product performance remains within nominal capacity.

Finish

- Body: RAL 7042 smooth gray polyester powder coating
- Grille: RAL 7035 light gray

Bulletin: MCL

Air Conditioners

Standard Product GENESIS Side-Mount 28 Series

Catalog Number	Voltage	Hz	Phase	BTU/Hr @ 125 F/125 F	Full Load Amps	Max. Amb. Temp. (°F)	Max. Amb. Temp. (°C)	Ship Wt. (lb.)	Ship Wt. (kg)
M280216G013	115	50/60	1	2200/2200	9.8/9.0	125	52	98	45
M280226G004	230	50/60	1	2200/2200	5.0/4.5	125	52	98	45
M280246G400	460	50/60	1	2200/2200	2.8/2.5	125	52	108	49
M280416G007	115	50/60	1	3800/4000	14.6/14.0	125	52	116	53
M280426G032	230	50/60	1	3800/4000	7.4/6.9	125	52	116	53
M280446G400	460	50/60	1	3800/4000	4.1/3.8	125	52	136	62

Replacement Filter No. 10100056

28 Series

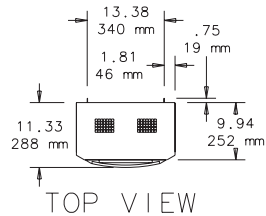

TOP VIEW

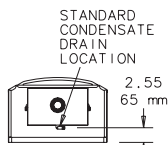

BOTTOM VIEW

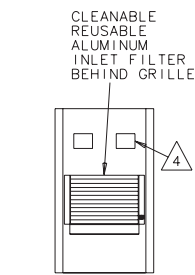

FRONT VIEW

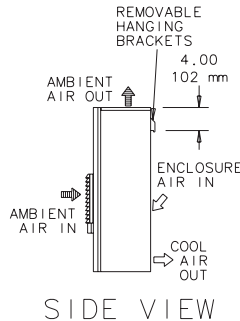

SIDE VIEW

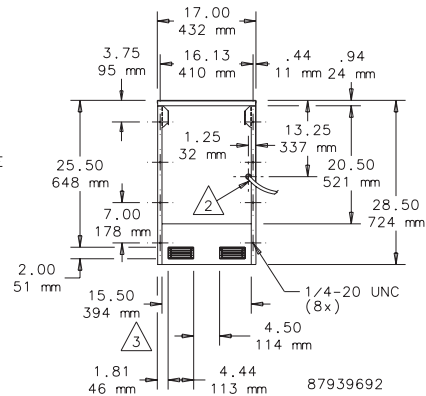

BACK VIEW

NOTE:

1. Gasket kit for mounting to enclosure included.
 2. Service cord.
 3. 20.50 x 15.50 inch area is recessed 1.00 inch from rear surface, or plenum.
 4. Condenser air discharge out front is optional.
- Number in triangle in CAD view refers to note number.

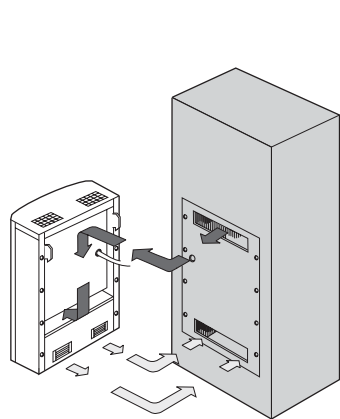

Side-Mount to Enclosure

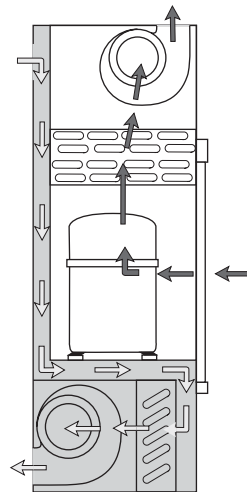

28 Series

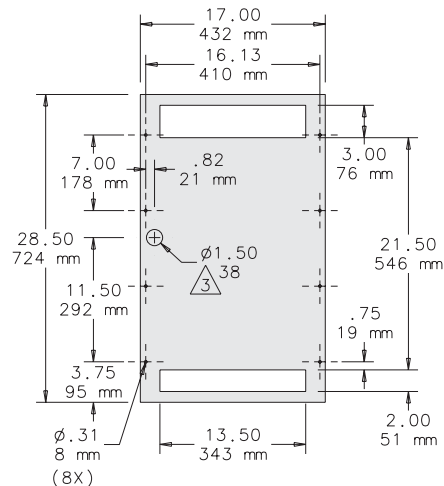

CUTOUT

NOTE:

1. Shaded area represents air conditioner.
 2. Cutout dimensions for standard products only.
 3. Hole may be deleted if the service cord is routed through the 3.00 x 13.50 inch return air opening.
 4. Full-size mounting template provided.
- Number in triangle in CAD view refers to note number.

Air Conditioners

Standard Product GENESIS Side-Mount 33 Series

Catalog Number	Voltage	Hz	Phase	BTU/Hr @ 125 F/125 F	Full Load Amps	Max. Amb. Temp. (°F)	Max. Amb. Temp. (°C)	Ship Wt. (lb.)	Ship Wt. (kg)
M330416G010	115	50/60	1	3700/4000	13.0/13.2	125	52	105	48
M330426G009	230	50/60	1	3700/4000	7.2/7.3	125	52	105	48
M330446G400	460	50/60	1	3700/4000	4.0/4.0	125	52	125	57

Replacement Filter No. 10100057

33 Series

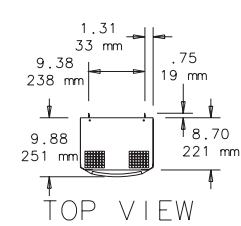

TOP VIEW

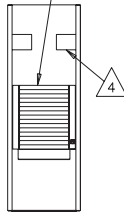
 CLEANABLE
REUSABLE
ALUMINUM
INLET FILTER
BEHIND GRILLE

FRONT VIEW

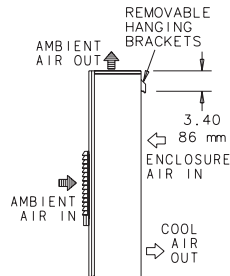

SIDE VIEW

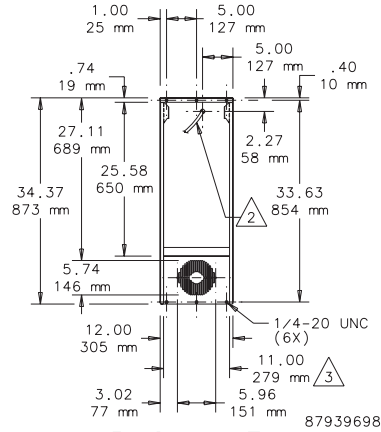

BACK VIEW

NOTE:

- Gasket kit for mounting to enclosure included.
 - Service cord.
 - 25.58 x 11.00 inch area is recessed 1.12 inches from rear surface, or plenum.
 - Condenser air discharge out front is optional.
- Number in triangle in CAD views refers to note number.

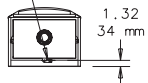
 STANDARD
CONDENSATE
DRAIN
LOCATION

BOTTOM VIEW

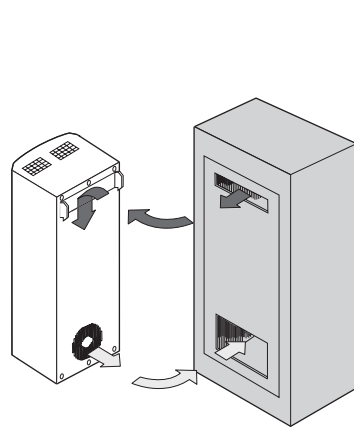

Side-Mount to Enclosure

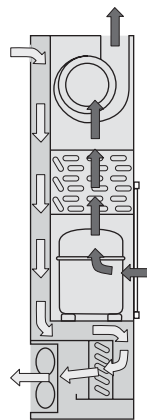

33NSM Series

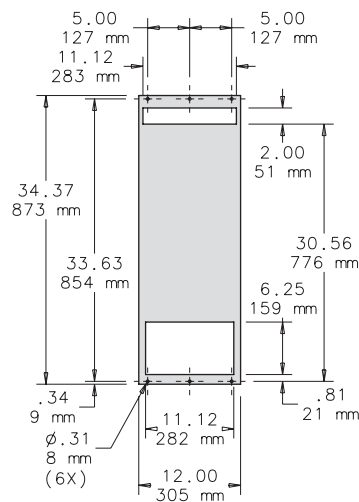

CUTOUT

NOTE:

- Shaded area represents air conditioner.
- Cutout dimensions for standard products only.
- Cord is routed through the 3.00 x 14.00 inch return air opening.
- Full-size mounting template provided.

Air Conditioners

Standard Product GENESIS Side-Mount 36 Series

Catalog Number	Voltage	Hz	Phase	BTU/Hr @ 131 F/131 F	Full Load Amps	Max. Amb. Temp. (°F)	Max. Amb. Temp. (°C)	Ship Wt. (lb.)	Ship Wt. (kg)
M360616G307	115	50/60	1	5000/6000	12.3	152	67	120	54
M360626G306	230	50/60	1	5000/6000	6.2	152	67	120	54
M360646G400	460	50/60	1	5000/6000	3.9	125	52	140	67

Replacement Filter No. 10100056

36 Series

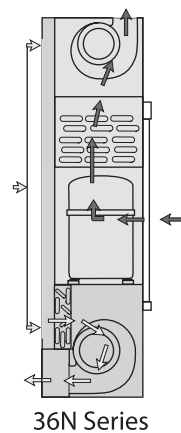
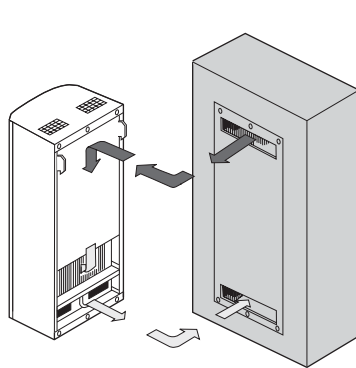
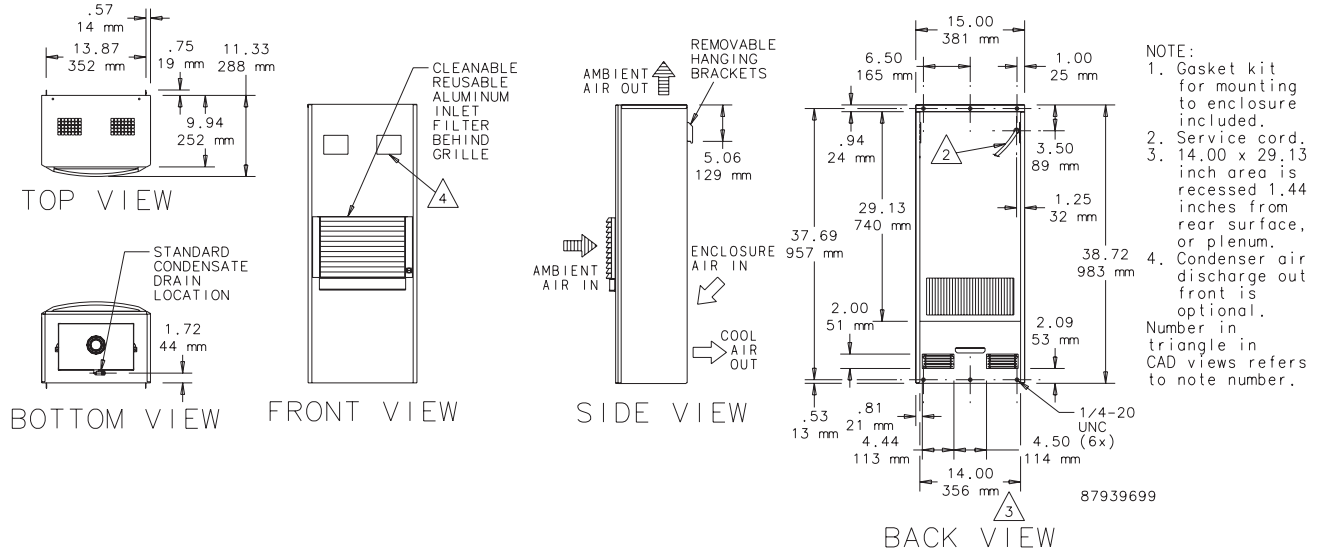

■ Ambient airflow
 ■ Clean airflow

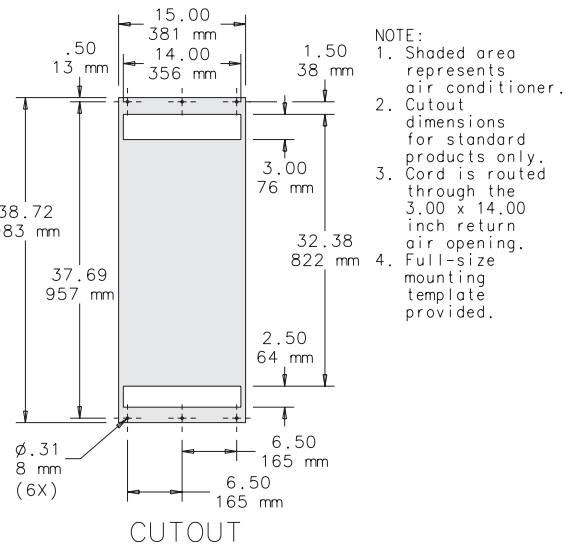

Air Conditioners

GENESIS™ 3-Phase 460-Volt Side-Mount Full-Size Air Conditioner



Industry Standards

Maintains UL/cUL Type 12 rating when properly installed on a UL/cUL Type 12 enclosure.

UL/cUL Listed; File No. SA6453

CE

Application

The efficient 3-phase, 460-volt compressor in the Genesis™ Full-Size Air Conditioner eliminates the need for additional transformers to cool controls in industrial, large enclosure applications.

Features

- Thermostat control
- Digital display of enclosure temperature
- High-temperature alarm
- High-performance centrifugal blowers
- Removable air filter
- Mounting brackets
- EMI/RFI noise suppression is standard
- Unique condensate management system
- All units use a universally accepted CFC-free or environmentally safe refrigerant
- Mounting gaskets and instruction manual furnished
- Closed-loop cooling

Finish

- Body: RAL 7042 smooth gray polyester powder coating
- Grille: RAL 7035 light gray

Bulletin: MCL

Standard Product

Catalog Number	AxBxC in./mm	Voltage	Hz	Phase	BTU/Hr. @ 125 F/125 F	Full Load Amps	Max. Amb. Temp. (°F)	Max. Amb. Temp. (°C)	Ship Wt. (lb.)	Ship Wt. (kg)
M520446G002	52.63 x 17.13 x 11.33 1337 x 435 x 288	460	50/60	3	3800/4100	1.8/1.6	125	52	162	74
M520646G002	52.63 x 17.13 x 11.33 1337 x 435 x 288	460	50/60	3	5700/6000	2.0/1.8	125	52	162	74
M520846G002	52.63 x 17.13 x 11.33 1337 x 435 x 288	460	50/60	3	6500/7500	3.5/3.2	125	52	162	74
M521046G002	52.63 x 17.13 x 11.33 1337 x 435 x 288	460	50/60	3	8000/10000	3.7/3.4	125	52	165	75

Replacement Filter No. 10100056

Air Conditioners

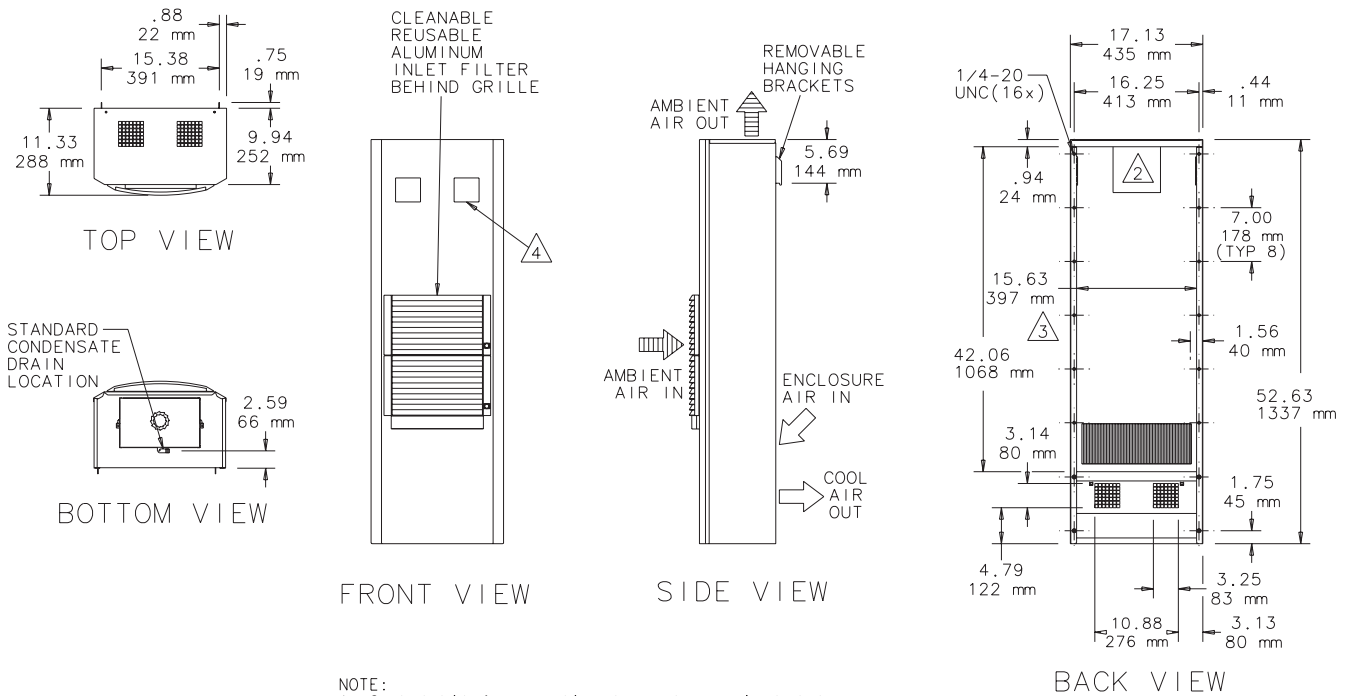

- NOTE:**
1. Gasket kit for mounting to enclosure included.
 2. 4 inch junction box with terminal block.
 3. 42.06 x 15.63 inch area is recessed 1.44 inches from rear surface, or plenum.
 4. Condenser air discharge out front is optional.
- Number in triangle in CAD views refers to note number.

87939701

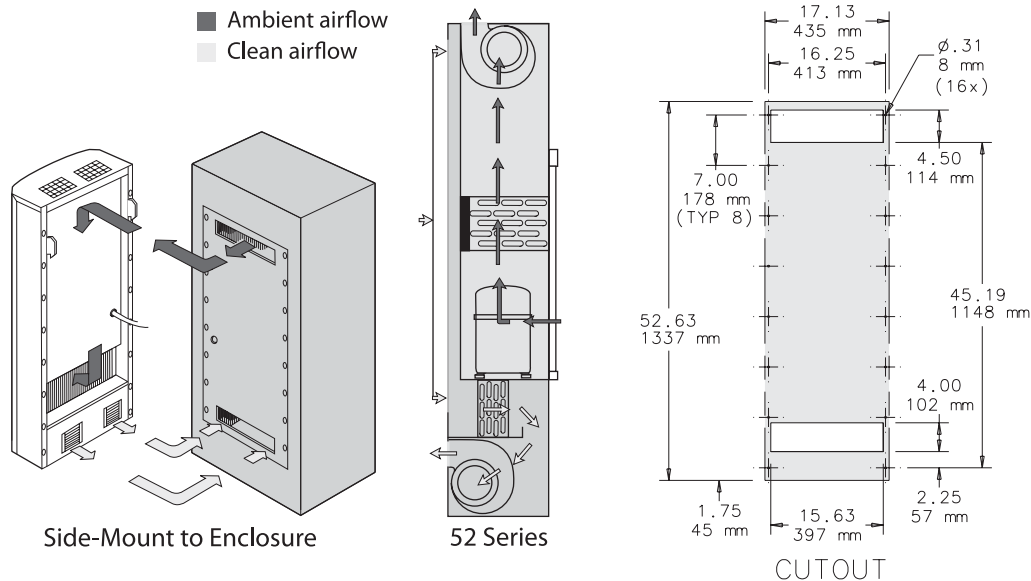

- NOTE:**
1. Shaded area represents air conditioner.
 2. Cutout dimensions for standard products only.
 3. Full-size mounting template provided.

Air Conditioners

GENESIS™ Top-Mount Series Air Conditioner



Industry Standards

Maintains UL/cUL Type 12 rating when properly installed on a UL/cUL Type 12 enclosure.

UL/cUL Recognized; File No. SA6453

CE

Application

The Top-Mount GENESIS™ Air Conditioner is ideal for applications that have little or no clearance around the sides of an enclosure.

Features

- Removable air filter
- High-performance CFM ball-bearing centrifugal blowers
- Unique condensate management system
- All units use a universally accepted CFC-free or environmentally safe refrigerant
- Mounting gaskets and instruction manual furnished
- Closed-loop cooling

Finish

- Body: RAL 7042 smooth gray polyester powder coating
- Grille: RAL 7035 light gray

Notes

Hoffman top-mount units are directly interchangeable with comparable GENESIS and Slimboy models.

Bulletin: MCL

Standard Product

Catalog Number	Voltage	Hz	Phase	BTU/Hr. (W) @ 125 F/125 F	Full Load Amps	Max. Amb. Temp. (°F)	Max. Amb. Temp. (°C)	Ship Wt. (lb.)	Ship Wt. (kg)
MHB110216G306	115	50/60	1	2200/2200	9.7/9.0	125	52	104	47
MHB110226G306	230	50/60	1	2200/2200	5.5/4.6	125	52	104	47
MHB110246G400	460	50/60	1	2200/2200	3.0/2.5	125	52	110	50
MHB110416G307	115	50/60	1	3300/4000	14.7/13.6	125	52	118	54
MHB110426G306	230	50/60	1	3300/4000	8.0/7.5	125	52	118	54
MHB110446G400	460	50/60	1	3300/4000	4.4/4.1	125	52	128	58

Replacement Filter No.10100056

Air Conditioners

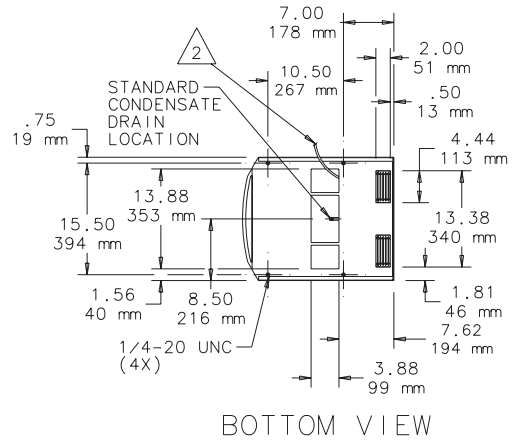
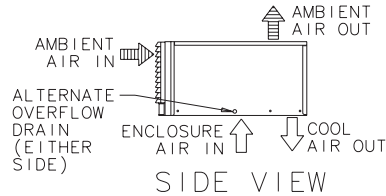
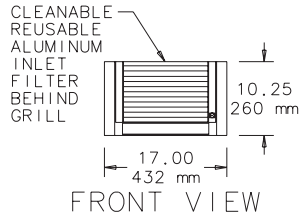
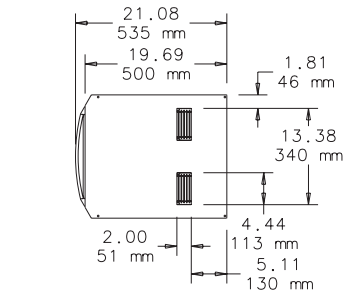

BOTTOM VIEW

87939702

- NOTE:
1. Gasket kit for mounting to enclosure included.
 2. Service cord.
 3. Condensate from enclosure drains to bottom of unit, where it is evaporated by condenser heat.
 4. Condensate overflow drain hose included.
- Number in triangle in CAD views refers to note number.

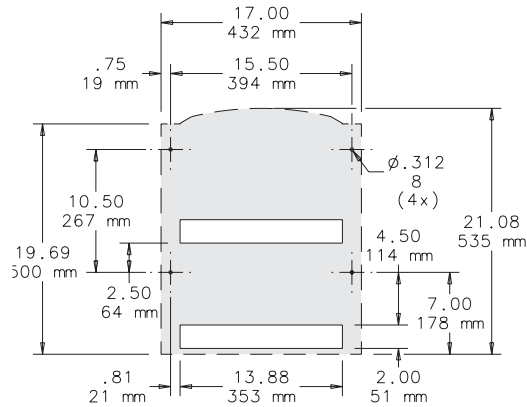

- NOTE:
1. Shaded area represents air conditioner.
 2. Cutout dimensions for standard products only.
 3. Full-size mounting template provided. Number in triangle in CAD views refers to note number.

CUTOUT

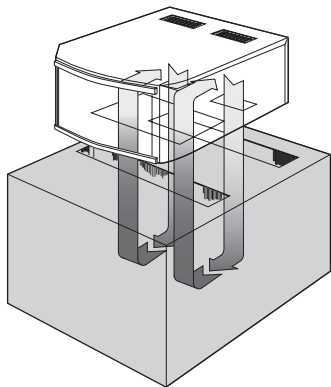

Top-Mount to Enclosure

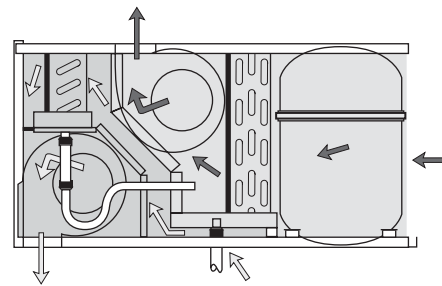

- Ambient airflow
- Clean airflow

Air Conditioners

CR Compact, Mid-Size and Full-Size Air Conditioners and Accessories



Shield maintains UL/cUL Type 4X rating. (Package 6) Ambient air enters from the bottom.

Industry Standards

Refer to tables for specific UL/cUL Type ratings these air conditioners maintain when properly installed on a UL/cUL rated enclosure.

UL/cUL Listed; File No. SA6453

CE

Application

CR Air Conditioners are available in a variety of configurations and sizes to match indoor or outdoor application requirements. CR23 and CR29 Air Conditioners feature an invertible, washable filter for easy maintenance.

Features

- Thermostat control and EMI/RFI noise suppressor included
- Front cover hinges open for quick access to all components
- Filter can be inverted to double operating time between cleanings and or replacements (models CR23 and CR29 only)
- Filterless operation possible in many applications
- Mounting flanges facilitate installation on door, side or front of enclosure

- For a typical application, unique condensate management system evaporates moisture from enclosure
- High-performance fans and blowers are ideal for densely-packed enclosures
- All units use a CFC-free or environmentally safe refrigerant that is universally accepted
- Mounting hardware, gaskets, mounting template and instruction manual furnished
- In accordance with the Montreal Protocol, the CR43 Air Conditioners have transitioned away from R22 refrigerant. Product performance remains within nominal capacity.

Finish

Available in brushed stainless steel or RAL 7035 light-gray polyester powder coating.

Notes

Some packages are not listed. Verify package before ordering.

Bulletin: MCL

Standard Product CR23 Air Conditioner Packages

Catalog Number	BTU/Voltage/Hz	Package	UL/cUL Type Rating
CR230216G002	1600 BTU/Hr. 115V-50/60 Hz	1 - Basic	12, 3R
CR230216G016	1600 BTU/Hr. 115V-50/60 Hz	2 - Level 2 Controller	12, 3R
CR230216G013	1600 BTU/Hr. 115V-50/60 Hz	3 - Low Ambient Temperature	12, 3R
CR230216G007	1600 BTU/Hr. 115V-50/60 Hz	4 - Low Ambient/SST/Corrosion	12, 3R
CR230216G017	1600 BTU/Hr. 115V-50/60 Hz	5 - Low Ambient/SST/Level 2	12, 3R
CR230216G015	1600 BTU/Hr. 115V-50/60 Hz	6 - Outdoor/SST/Corrosion/4X	4, 4X, 12
CR230226G002	1600 BTU/Hr. 230V-50/60 Hz	1 - Basic	12, 3R
CR230226G030	1600 BTU/Hr. 230V-50/60 Hz	3 - Low Ambient Temperature	12, 3R
CR230226G016	1600 BTU/Hr. 230V-50/60 Hz	5 - Low Ambient/SST/Level 2	12, 3R
CR230226G014	1600 BTU/Hr. 230V-50/60 Hz	6 - Outdoor/SST/Corrosion/4X	4, 4X, 12

Air Conditioners

CR23

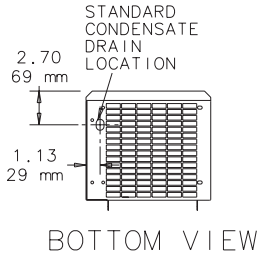
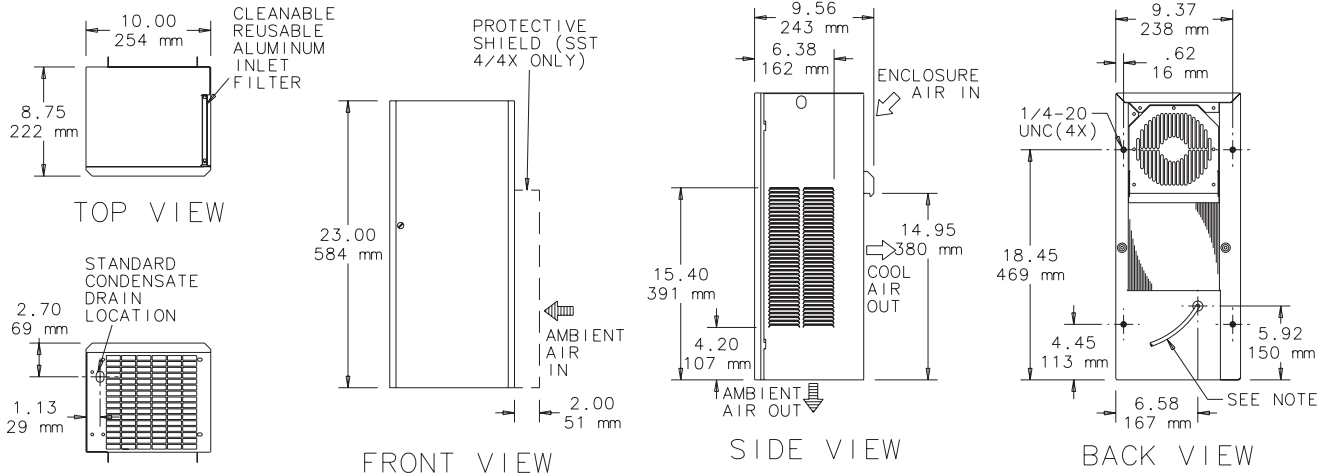

NOTE: Service cord terminated with appropriate plug cap.

87939703

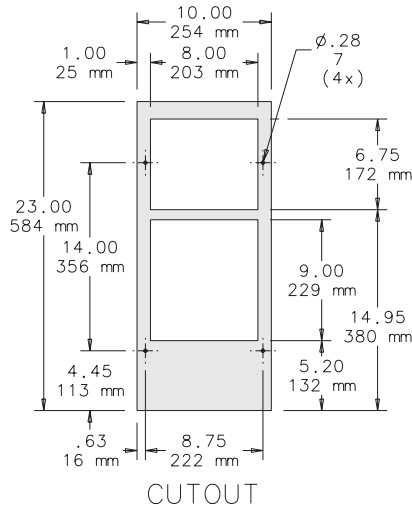

- NOTE:
1. Shaded area represents air conditioner.
 2. Cutout dimensions for standard products only.
 3. Full-size mounting template provided.

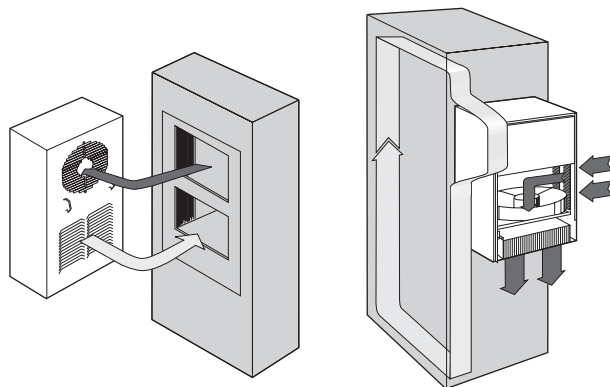

■ Ambient airflow
 ■ Clean airflow

Air Conditioners

Standard Product CR29 Air Conditioner Packages

Catalog Number	BTU/Voltage/Hz	Package
CR290216G002	2200 BTU/Hr. 115V-50/60 Hz	1 - Basic
CR290216G030	2200 BTU/Hr. 115V-50/60 Hz	2 - Level 2 Controller
CR290216G035	2200 BTU/Hr. 115V-50/60 Hz	3 - Low Ambient Temperature
CR290216G013	2200 BTU/Hr. 115V-50/60 Hz	4 - Low Ambient/SST/Corrosion
CR290216G036	2200 BTU/Hr. 115V-50/60 Hz	6 - Outdoor/SST/Corrosion/4X
CR290226G002	2200 BTU/Hr. 230V-50/60 Hz	1 - Basic
CR290226G030	2200 BTU/Hr. 230V-50/60 Hz	2 - Level 2 Controller
CR290226G020	2200 BTU/Hr. 230V-50/60 Hz	3 - Low Ambient Temperature
CR290226G010	2200 BTU/Hr. 230V-50/60 Hz	4 - Low Ambient/SST/Corrosion
CR290226G031	2200 BTU/Hr. 230V-50/60 Hz	5 - Low Ambient/SST/Level 2
CR290226G037	2200 BTU/Hr. 230V-50/60 Hz	6 - Outdoor/SST/Corrosion/4X
CR290416G002	4000 BTU/Hr. 115V-50/60 Hz	1 - Basic
CR290416G047	4000 BTU/Hr. 115V-50/60 Hz	2 - Level 2 Controller
CR290416G045	4000 BTU/Hr. 115V-50/60 Hz	3 - Low Ambient Temperature
CR290416G030	4000 BTU/Hr. 115V-50/60 Hz	4 - Low Ambient/SST/Corrosion
CR290416G052	4000 BTU/Hr. 115V-50/60 Hz	5 - Low Ambient/SST/Level 2
CR290416G068	4000 BTU/Hr. 115V-50/60 Hz	6 - Outdoor/SST/Corrosion/4X
CR290426G002	4000 BTU/Hr. 230V-50/60 Hz	1 - Basic
CR290426G027	4000 BTU/Hr. 230V-50/60 Hz	2 - Level 2 Controller
CR290426G022	4000 BTU/Hr. 230V-50/60 Hz	3 - Low Ambient Temperature
CR290426G017	4000 BTU/Hr. 230V-50/60 Hz	4 - Low Ambient/SST/Corrosion
CR290426G054	4000 BTU/Hr. 230V-50/60 Hz	6 - Outdoor/SST/Corrosion/4X

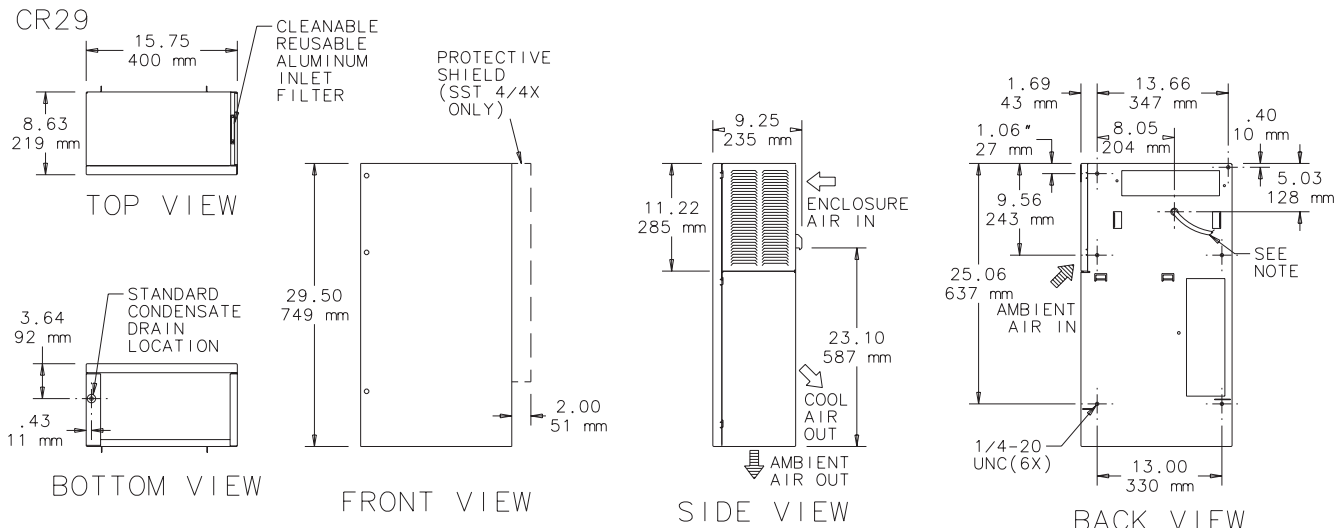

- NOTE:
1. Shaded area represents air conditioner.
 2. Cutout dimensions for standard products only.
 3. Full-size mounting template provided.

NOTE: Service cord terminated with appropriate plug cap.

87939704

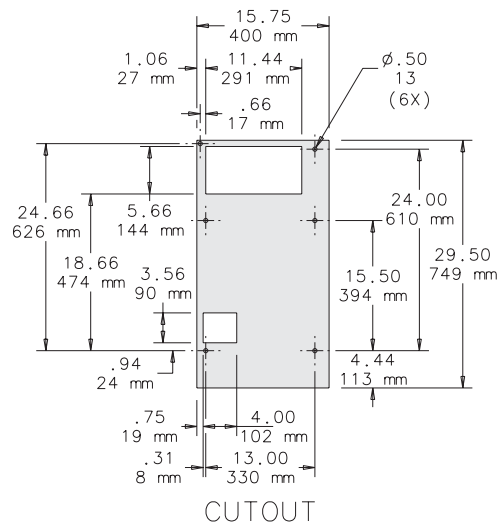
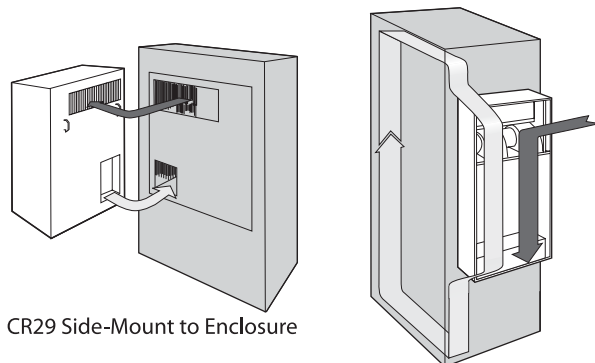

Air Conditioners

Standard Product CR43 Air Conditioner Packages

Catalog Number	BTU/Voltage/Hz	Package
CR430616G002H	6500 BTU/Hr. 115V-50/60 Hz	1 - Basic
CR430616G016	6500 BTU/Hr. 115V-50/60 Hz	2 - Level 2 Controller
CR430616G013	6500 BTU/Hr. 115V-50/60 Hz	3 - Low Ambient Temperature
CR430616G004	6500 BTU/Hr. 115V-50/60 Hz	4 - Low Ambient/SST/Corrosion
CR430616G031	6500 BTU/Hr. 115V-50/60 Hz	6 - Outdoor/SST/Corrosion/4X
CR430626G002H	6500 BTU/Hr. 230V-50/60 Hz	1 - Basic
CR430626G018	6500 BTU/Hr. 230V-50/60 Hz	2 - Level 2 Controller
CR430626G014	6500 BTU/Hr. 230V-50/60 Hz	3 - Low Ambient Temperature
CR430626G020	6500 BTU/Hr. 230V-50/60 Hz	5 - Low Ambient/SST/Level 2
CR430626G034	6500 BTU/Hr. 230V-50/60 Hz	6 - Outdoor/SST/Corrosion/4X
CR430816G002H	8000 BTU/Hr. 115V-50/60 Hz	1 - Basic
CR430816G021	8000 BTU/Hr. 115V-50/60 Hz	2 - Level 2 Controller
CR430816G038	8000 BTU/Hr. 115V-50/60 Hz	3 - Low Ambient Temperature
CR430816G010	8000 BTU/Hr. 115V-50/60 Hz	4 - Low Ambient/SST/Corrosion
CR430816G023	8000 BTU/Hr. 115V-50/60 Hz	5 - Low Ambient/SST/Level 2
CR430816G036	8000 BTU/Hr. 115V-50/60 Hz	6 - Outdoor/SST/Corrosion/4X
CR430826G002H	8000 BTU/Hr. 230V-50/60 Hz	1 - Basic
CR430826G026	8000 BTU/Hr. 230V-50/60 Hz	2 - Level 2 Controller
CR430826G007	8000 BTU/Hr. 230V-50/60 Hz	3 - Low Ambient Temperature
CR430826G037	8000 BTU/Hr. 230V-50/60 Hz	4 - Low Ambient/SST/Corrosion
CR430826G024	8000 BTU/Hr. 230V-50/60 Hz	5 - Low Ambient/SST/Level 2
CR430826G038	8000 BTU/Hr. 230V-50/60 Hz	6 - Outdoor/SST/Corrosion/4X

CR43

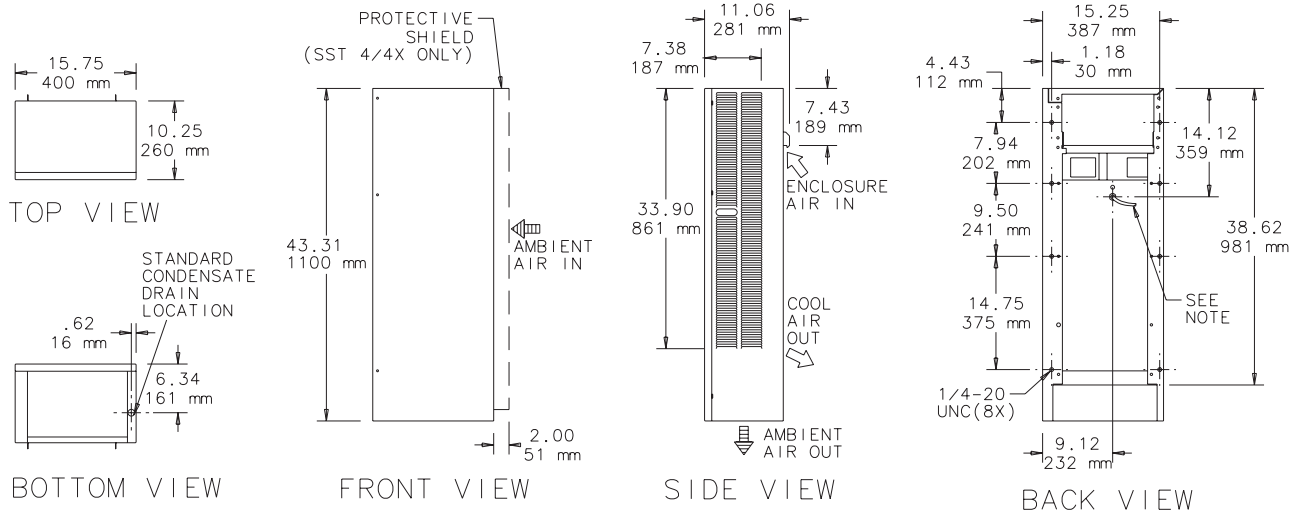

NOTE: Service cord terminated with appropriate plug cap.

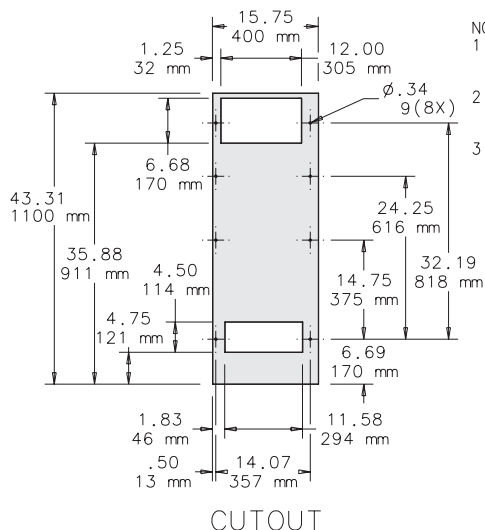

- NOTE:
1. Shaded area represents air conditioner.
 2. Cutout dimensions for standard products only.
 3. Full-size mounting template provided.

87939705

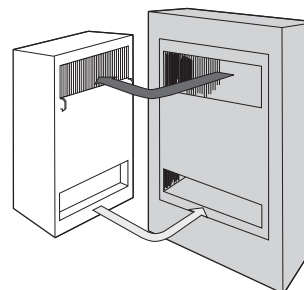

CR43 Side-Mount to Enclosure

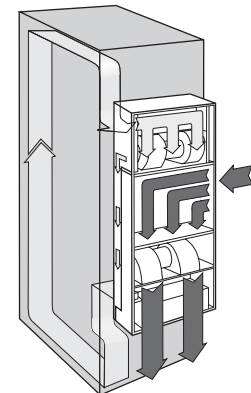

Air Conditioners

CR23 Series

Catalog Numbers	Voltage	Hz	Phase	BTU/Hr. @		Amps @		Max. Amb. Temp. (°F)	Max. Amb. Temp. (°C)	Ship Wt. (lb.)	Ship Wt. (kg)
				131 F/131 F	131 F/131 F	95 F/95 F	95 F/95 F				
CR230216GXXX	115	50/60	1	1400/1600	4.1/4.5	1500/1700	3.8/3.6	131	55	57	26
CR230226GXXX	230	50/60	1	1400/1600	2.2/2.2	1500/1700	2.1/1.8	131	55	57	26

Because air conditioners provide less cooling at lower operating temperatures, two cooling capacity ratings are provided.

For Stainless Steel UL Type 4X models, add approximately 10 lb. to shipping weight.

Replacement Filter No. 23200400

CR29 Series

Catalog Numbers	Voltage	Hz	Phase	BTU/Hr. @		Amps @		Max. Amb. Temp. (°F)	Max. Amb. Temp. (°C)	Ship Wt. (lb.)	Ship Wt. (kg)
				131 F/131 F	131 F/131 F	95 F/95 F	95 F/95 F				
CR290216GXXX	115	50/60	1	2000/2200	7.4/7.4	1700/2000	7.0/6.0	131	55	98	44
CR290226GXXX	230	50/60	1	2500/2700	4.6/3.9	1900/2300	4.4/3.3	131	55	98	44
CR290416GXXX	115	50/60	1	3500/4000	13.5/13.5	2400/2800	10.7/9.06	131	55	118	54
CR290426GXXX	230	50/60	1	3500/4000	6.7/6.7	2400/2800	5.9/5.3	131	55	118	54

Because air conditioners provide less cooling at lower operating temperatures, two cooling capacity ratings are provided.

For Stainless Steel UL Type 4X models, add approximately 10 lb. to shipping weight.

Replacement Filter No. 10100032

CR43 Series

Catalog Numbers	Voltage	Hz	Phase	BTU/Hr. @		Amps @		Max. Amb. Temp. (°F)	Max. Amb. Temp. (°C)	Ship Wt. (lb.)	Ship Wt. (kg)
				131 F/131 F	131 F/131 F	95 F/95 F	95 F/95 F				
CR430616GXXX	115	60	1	6500	12.0	6000	11.0	131	55	133	60
CR430626GXXX	230	60	1	6500	3.0	6000	5.5	131	55	133	60
CR430816GXXX	115	60	1	8000	14.0	7000	12.9	131	55	140	64
CR430826GXXX	230	60	1	8000	7.1	7000	6.3	131	55	140	64

Because air conditioners provide less cooling at lower operating temperatures, two cooling capacity ratings are provided.

For Stainless Steel UL Type 4X models, add approximately 10 lb. to shipping weight.

Replacement Filter No. 10100044

Air Conditioners

Closed Loop Cooling

Within the air conditioner, the recirculated clean air is kept separate from the ambient airflow system. This protects the electronic controls and prevents shutdowns caused by heat, humidity, dust and other contaminants.

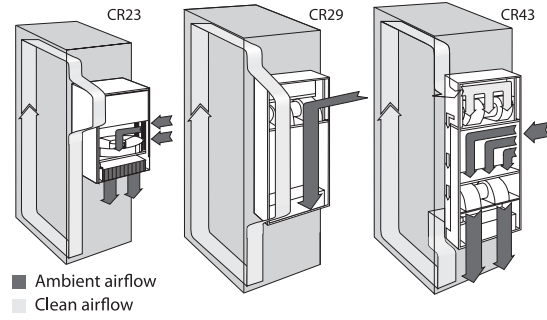

Vortex Cooling Systems and Accessories

Vortex Cooling System



Industry Standards

NEMA Type 4 Models:

Maintains UL/cUL Type 4 when properly installed on a UL/cUL Type 4 enclosure.

UL508 Listed; Type 4; File No. E187045

NEMA Type 4X Models:

Maintains UL/cUL Type 4X when properly installed on a UL/cUL Type 4X enclosure.

UL508 Listed; Type 4X; File No. E187045

NEMA Type 12 Models:

Maintains UL/cUL Type 12 when properly installed on a UL/cUL Type 12 enclosure.

UL508 Listed; Type 12; File No. E187045

Application

Powered by compressed air, Vortex Cooling Systems generate chilled air to cool small enclosures without refrigerants or moving parts. These systems are exceptionally reliable and low maintenance, even in the harshest and dirtiest environments.

Features

- Five-micron airline filter, 115 V solenoid
- Thermostat
- Ducting kit
- Cooling capacities to 2500 Btu/Hr. (733 W)

Finish

Brushed satin aluminum or stainless steel

Accessories

(for the enclosure)
Can be installed on all enclosure product families. Separate VCool accessories include an in-line oil filter.

Notes

Manufactured for Hoffman by ITW Vortec.

Bulletin: [MCL](#), [MCLY](#)

Standard Product VC Series NEMA Type 12

Catalog Number	Cooling Capacity (BTU/Hr.)	Cooling Capacity (W)	Compressed Air Consumption (SCFM)	Compressed Air Consumption (l ³ /m)	Noise Level (dB)	Voltage	Frequency (Hz)	Material	Weight (lb.)	Weight (kg)
VC0416012	400	117	8	227	69	115	50/60	Aluminum	5	2.27
VC0916012	900	264	15	425	80	115	50/60	Aluminum	6	2.72
VC1516012	1500	440	25	708	83	115	50/60	Aluminum	6	2.72
VC2516012	2500	733	35	991	90	115	50/60	Aluminum	6	2.72

Vortex Cooling Systems and Accessories

NEMA Type 12 - 400 BTU/Hr.

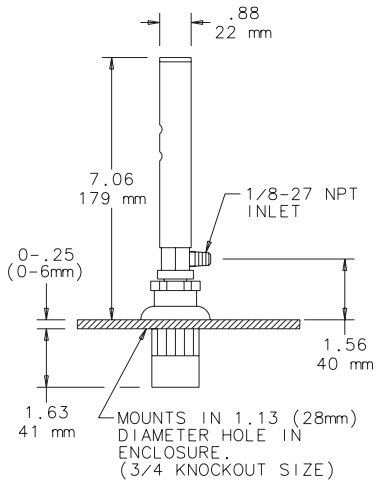

NEMA Type 12 - 900, 1500, 2500 BTU/Hr.

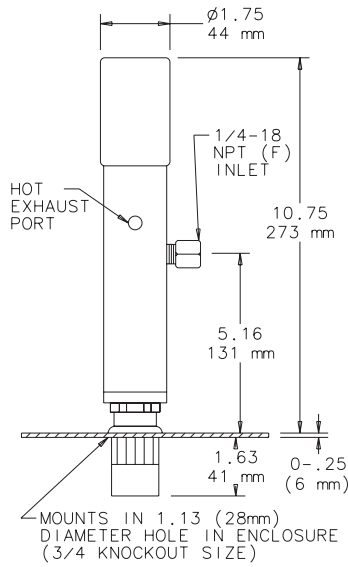

NEMA Type 4X 900, 1700, 2500 BTU/Hr.

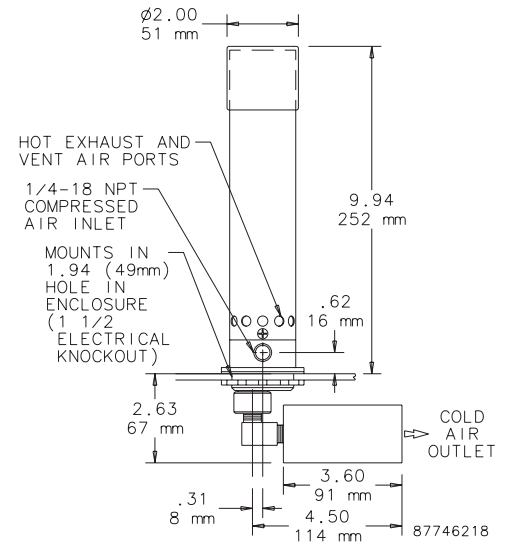

ENCLOSURE COOLER MUST REMAIN IN A VERTICAL ORIENTATION TO MAINTAIN NEMA 4/4X RATINGS.

Typical Installation

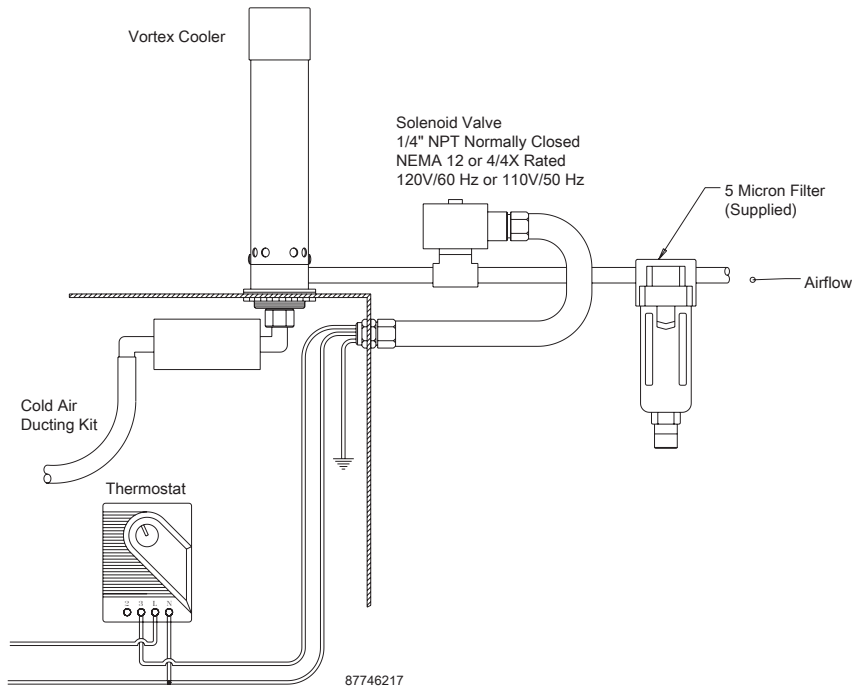

Vortex Cooling Systems and Accessories

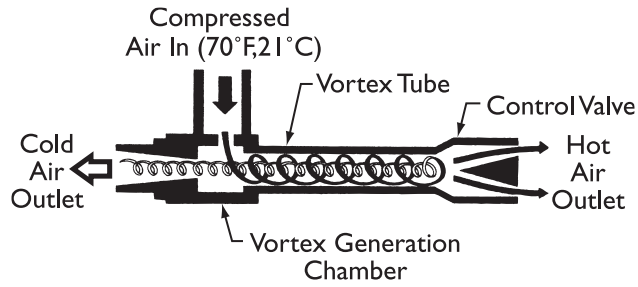

Vortex Tube Air Flow Schematic

Standard Product **VC Series NEMA Type 4, 4X**

Catalog Number	Cooling Capacity (BTU/Hr.)	Cooling Capacity (W)	Compressed Air Consumption (SCFM)	Compressed Air Consumption (l ³ /m)	Noise Level (dB)	Voltage	Frequency (Hz)	Material	Weight (lb.)	Weight (kg)
VC0916004	900	264	15	425	83	115	50/60	Aluminum	6	2.72
VC1716004	1700	498	25	708	86	115	50/60	Aluminum	6	2.72
VC2516004	2500	733	35	991	90	115	50/60	Aluminum	6	2.72
VC091604X	900	264	15	425	83	115	50/60	Stainless Steel	6	2.72
VC171604X	1700	498	25	708	86	115	50/60	Stainless Steel	6	2.72
VC251604X	2500	733	35	991	90	115	50/60	Stainless Steel	6	2.72

Vortex Cooling System Accessories

Catalog Number	Description	Use with VCool Model Capacity
VCOF17	Oil Filter	Up to 1700 BTU/Hr.
VCOF25	Oil Filter	2500 BTU/Hr.



Vortex Cooling Systems and Accessories

Notes

Heat Exchangers Sizing and Selection

Heat Exchangers Sizing and Selection Overview

Before choosing a thermal management solution, you need to carefully consider the specifics of your application in addition to the following factors:

- Fan packages and blowers may introduce ambient contaminants like oil mist and dust into the enclosure
- Heat exchangers (this section) cannot cool below the ambient temperature
- Closed-loop air conditioners can cool below ambient temperature and reduce humidity without introducing contaminants
- Simple ventilation devices such as louvers or grilles and filters are appropriate if maintaining a cool, constant temperature is not a critical factor

Once you have determined the proper form of cooling equipment you need, selecting the required cooling capacity is outlined in this section.

When Should You Use a Heat Exchanger?

A heat exchanger is recommended when:

- ambient air contaminants must be kept out of the enclosure
- the integrity of the enclosure must be maintained
- temperature slightly above ambient inside the cabinet is acceptable
- humidity is not a factor

How to Read Heat Exchanger Catalog Numbers

XR - 29 - 18 - 1 - 6 - 012

XR = Heat Exchanger Series; XR Modified Heat Pipe Core heat exchanger

29 = Approximate height of the heat exchanger (i.e., 29 = 29-in. high)

18 = Capacity in W/°F

1 = 115 V, 2 = 230 V

6 = 50/60 Hz

012 = UL Type

Heat Exchanger Sizing

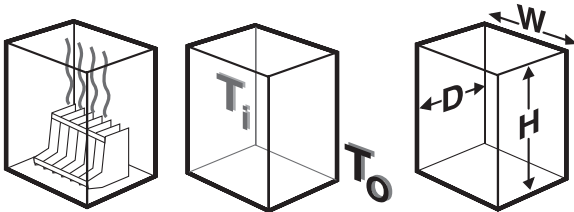

1. Determine internal heat load in Watts (W).

$$1 \text{ W} = 3.413 \text{ BTU/Hr.}$$

Determine the internal heat load produced by equipment as total operating Watts.

2. Determine desired temperature difference in degrees F.

$$1 \text{ K } \Delta T = 1.8 \text{ F } \Delta T \quad \text{K } \Delta T = \text{ } ^\circ\text{C } \Delta T$$

Determine the ΔT (°F), the temperature difference between the maximum temperature outside the enclosure (T_o) and the maximum desired temperature inside the enclosure (T_i), which can be calculated as:

$$T_i - T_o = \Delta T \text{ for heat exchangers.}$$

3. Determine exposed surface area of the enclosure in square feet.

$$\text{Area (ft.}^2\text{)} \quad 1 \text{ m}^2 = 10.76 \text{ ft.}^2$$

Calculate the exposed surface area of the enclosure in Square Feet:

$$\text{Area (ft.}^2\text{)} = 2[(H \times W) + (H \times D) + (W \times D)] \div 144$$

where "H", "W", and "D" are the dimensions of the enclosure.

4. Determine required heat exchanger performance rating.

$$\text{Watts} \div \Delta T(\text{ } ^\circ\text{F}) - [0.22 \times \text{Area (ft.}^2\text{)}] = \text{Watts/ } ^\circ\text{F}$$

Use this formula to determine the required cooling capacity needed to maintain the desired operating temperature for your enclosure. This selection procedure applies to uninsulated, sealed, gasketed enclosures in indoor locations.

It is recommended that the average "Air In" rating be used when sizing an application. However, it may be possible to use a lower-rated heat exchanger by locating the most heat-sensitive components in line with the "Air Out" opening of the heat exchanger. The actual performance rating of any heat exchanger may vary slightly because of the airflow impedance of the specific electronics configurations.

Heat Exchangers Sizing and Selection

Thermal Management Sizing and Selection Software



Designed to assist you in determining the most suitable choices of air conditioners, heat exchangers or fans for your application. Download a free copy of our selection software by visiting our web site: hoffmanonline.com. Click on **Thermal Management** chapter.

Compact and Mid-Size Heat Exchangers



XR Compact and Mid-Size

Series	A (in.)	A (mm)	B (in.)	B (mm)	C (in.)	C (mm)	Enclosure Air In (W/°F)	Enclosure Air In (W/K)	Enclosure Air Out (W/°F)	Enclosure Air Out (W/K)
XR2004_	20.00	508	7.50	191	3.00	76	4	7	9	16
XR2908_	29.50	749	10.00	254	3.09	79	8	14	30	54
XR2918_	29.66	753	10.24	260	5.92	150	18	32	34	61
XR4724_	47.16	1198	10.24	260	5.92	150	24	43	44	79
XR4735_	47.16	1198	15.24	387	5.92	150	34	63	77	139
XR6055_	59.66	1515	15.24	387	5.92	150	55	99	138	248
XR6084_	59.66	1515	15.24	387	9.92	252	84	151	210	378

Heat Exchangers

CLIMAGUARD™ Outdoor Heat Exchangers



Application

The CLIMAGUARD™ Outdoor Heat Exchanger is a rugged and reliable unit engineered for temperature extremes, corrosive environments and wind-driven rain. Its design keeps enclosures sealed tight for reliable closed-loop cooling while ensuring vital electronics stay protected.

Features

- Removes up to 3000 W of enclosure heat
- Available in DC and AC power supply
- Cooling capacities ranging from 25 W/°C (14 W/°F) and 150 W/°C (83 W/°F)
- Variable-speed blowers standard on DC-powered units
- Surface- and recess-mount capable
- Gasket and hardware included
- Few moving parts
- Double-sealed core ends
- Closed-loop cooling

Specifications

- Powder-coated galvanized sheet metal shroud
- Corrosion-resistant aluminum core

Finish

RAL 7035 smooth light-gray polyester powder coating

Accessories

Ambient-side insect screen
Up to 2000 Watt heater for DC and AC models

Bulletin: MCLHE

Industry Standards

Maintains UL/cUL Type 4, 12, 3R rating when properly installed on the appropriate UL/cUL Type 4, 12, 3R enclosure.

UL/cUL Listed, UL File No. SA7402

Standard Product

Catalog Number	AxBxC in.	AxBxC mm	Power Source	Voltage	Hz	Phase	Full Load Amps	Operating Temp. Range (°F)	Operating Temp. Range (°C)	Cooling Capacity (W/°F)	Cooling Capacity (W/°C)	Ship Wt. (lb.)	Ship Wt. (kg)
TX231416100	23.00 x 12.00 x 7.10	584 x 305 x 180	AC	115	50/60	1	.6	-40 - 149	-40 - 65	14	25	32	14.5
TX231448100	23.00 x 12.00 x 7.10	584 x 305 x 180	DC	48	—	—	1.8	-40 - 149	-40 - 65	14	25	32	14.5
TX332816100	33.00 x 15.70 x 8.10	838 x 399 x 206	AC	115	50/60	1	1.4	-40 - 149	-40 - 65	28	50	52	23.6
TX332848100	33.00 x 15.70 x 8.10	838 x 399 x 206	DC	48	—	—	1.8	-40 - 149	-40 - 65	28	50	52	23.6
TX385616100	38.00 x 19.70 x 10.10	965 x 500 x 257	AC	115	50/60	1	2.3/3.2	-40 - 149	-40 - 65	56	100	69	31.3
TX385648100	38.00 x 19.70 x 10.10	965 x 500 x 257	DC	48	—	—	5.8	-40 - 149	-40 - 65	56	100	69	31.3
TX528316100	52.00 x 19.70 x 10.10	1321 x 500 x 257	AC	115	50/60	1	4.3/6.7	-40 - 149	-40 - 65	83	150	103	46.7
TX528348100	52.00 x 19.70 x 10.10	1321 x 500 x 257	DC	48	—	—	7.8	-40 - 149	-40 - 65	83	150	103	46.7

TX23 Models For AC Power Supply

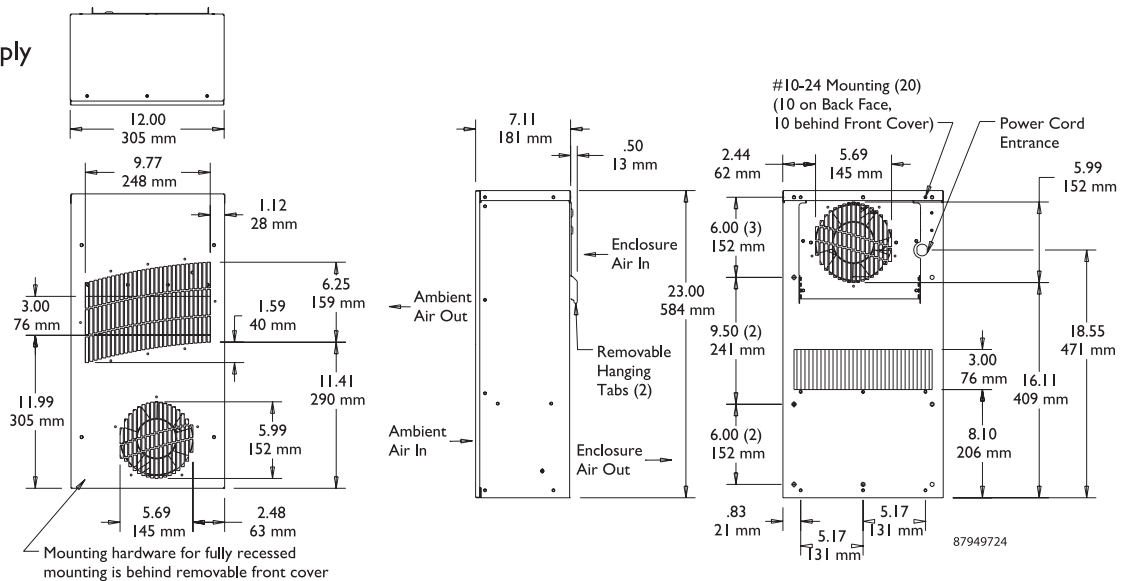

Heat Exchangers

TX23 Models For DC Power Supply

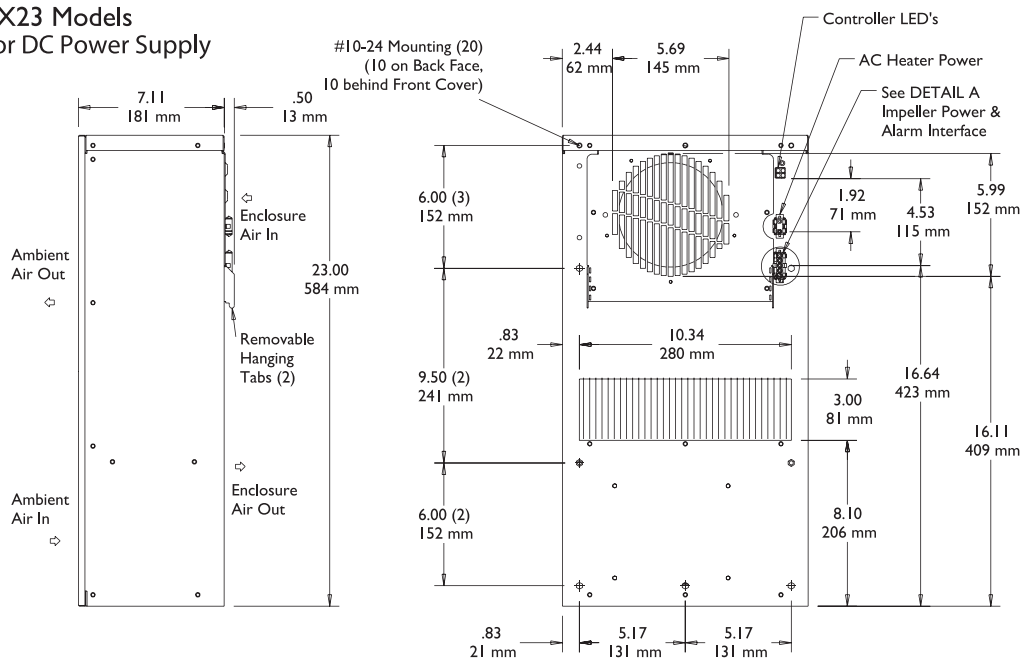

87949725

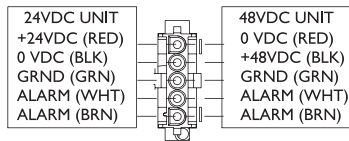

DETAIL A

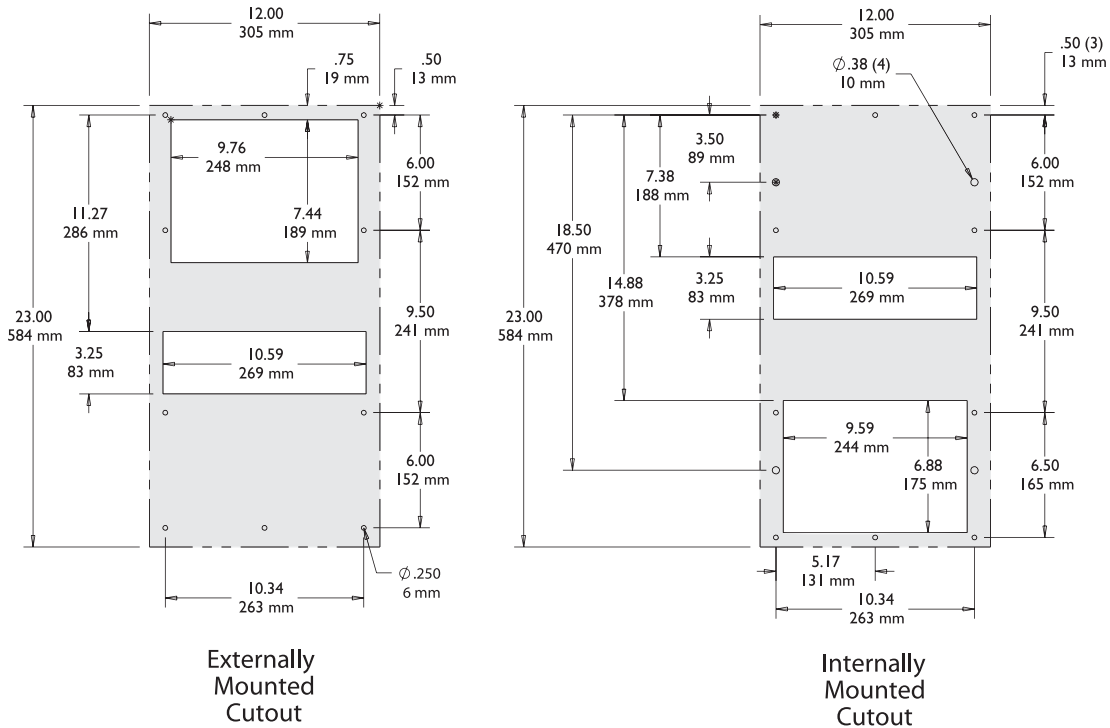

Heat Exchangers

TX33 Models
For AC Power Supply

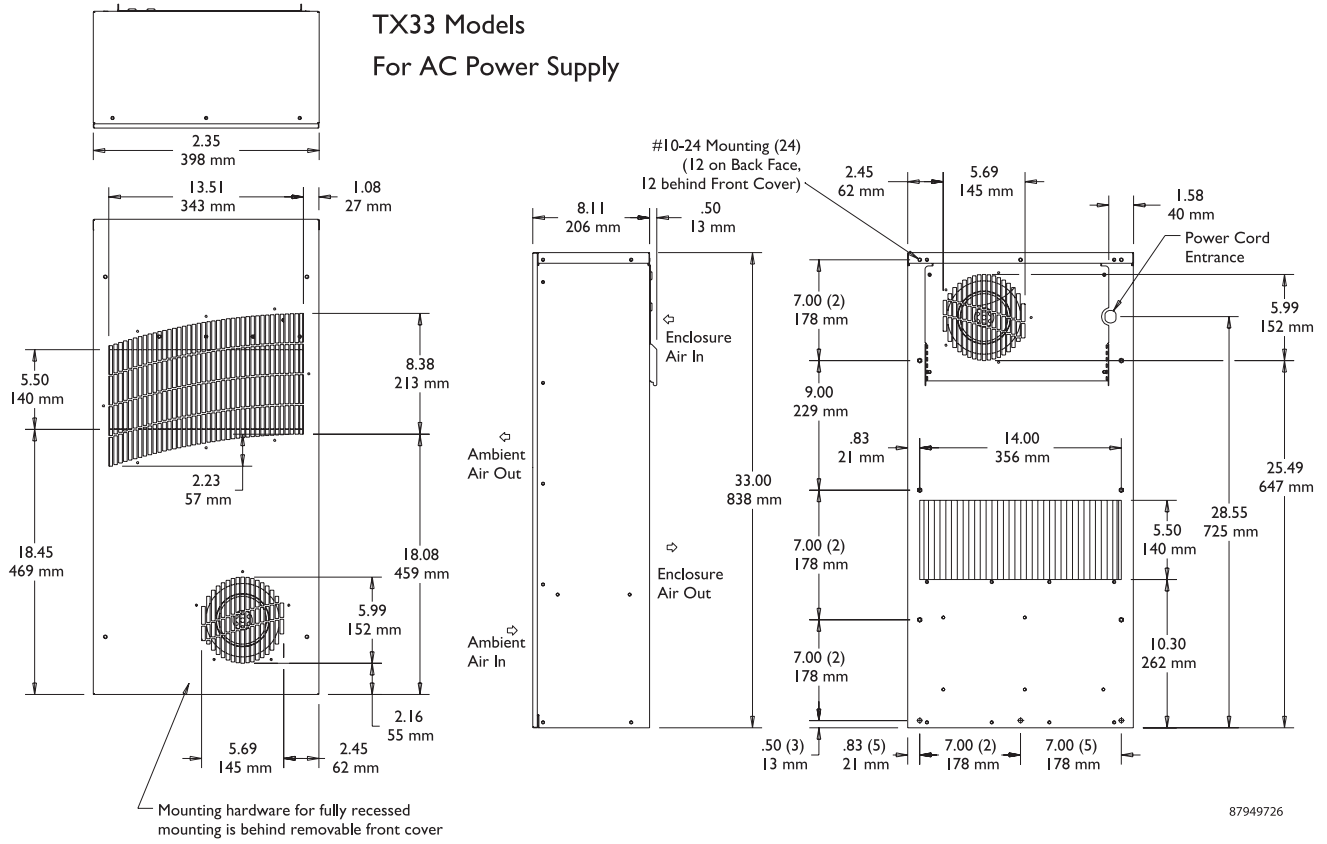

87949726

Heat Exchangers

TX33 Models For DC Power Supply

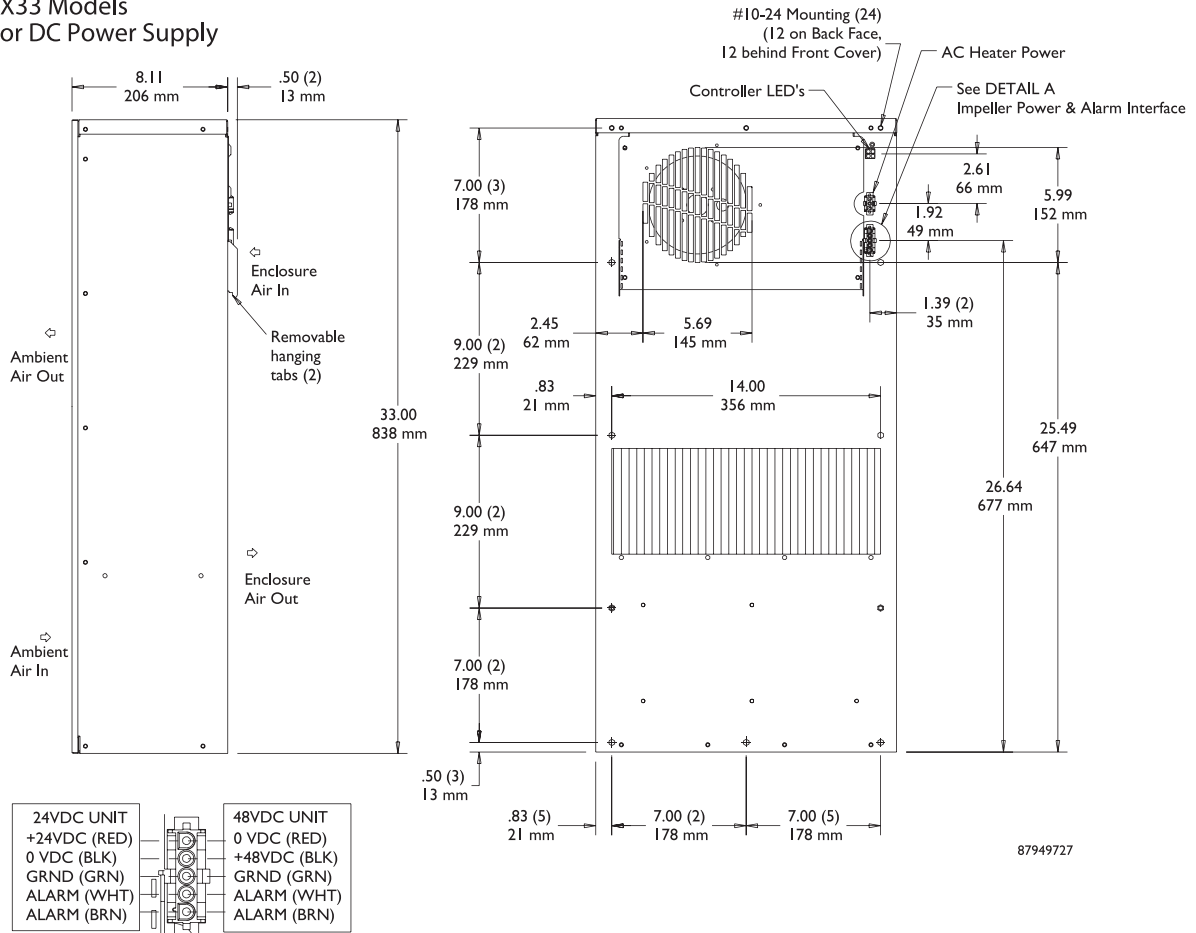

DETAIL A

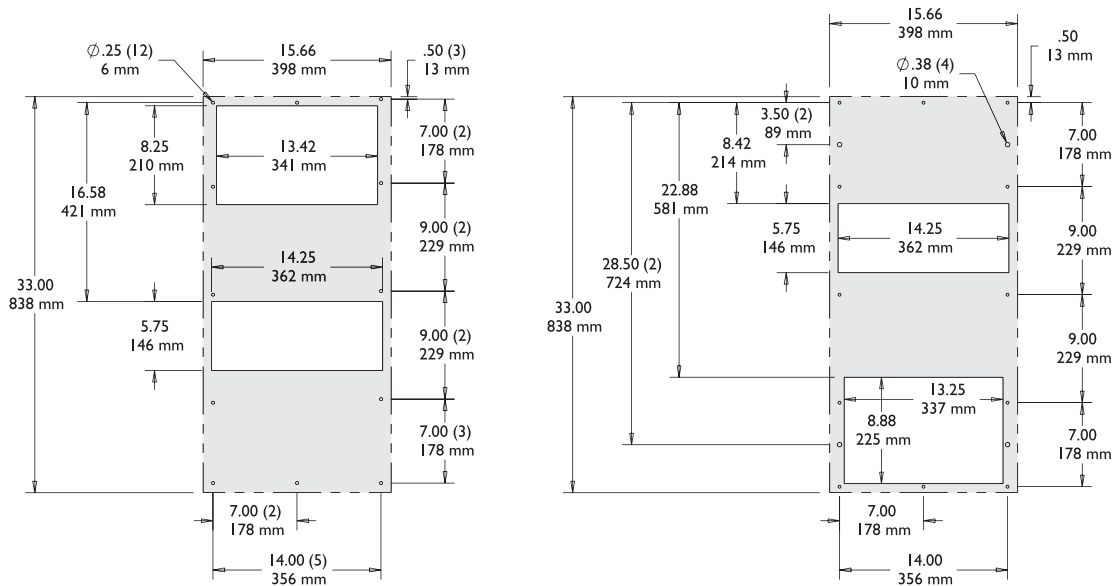

Externally Mounted Cutout

Internally Mounted Cutout

Heat Exchangers

TX38 Models For DC Power Supply

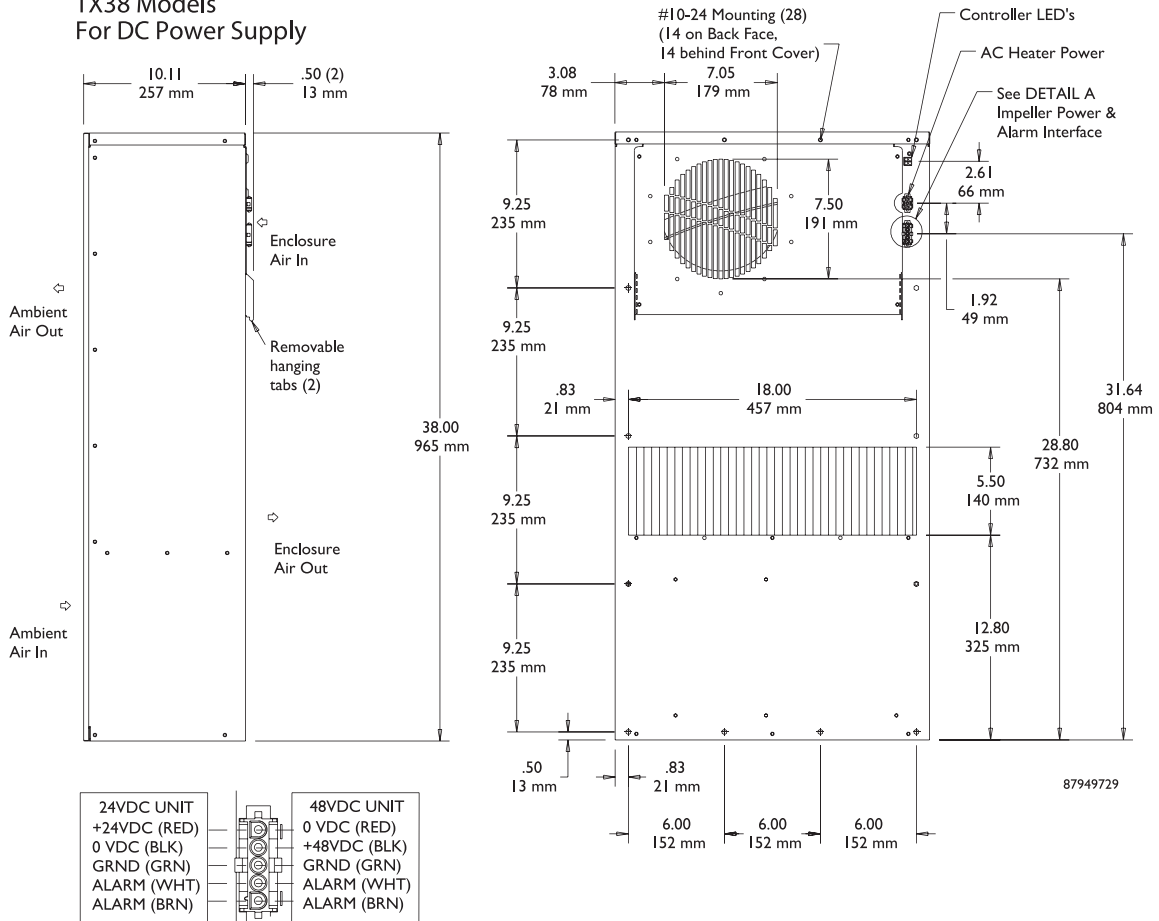

DETAIL A

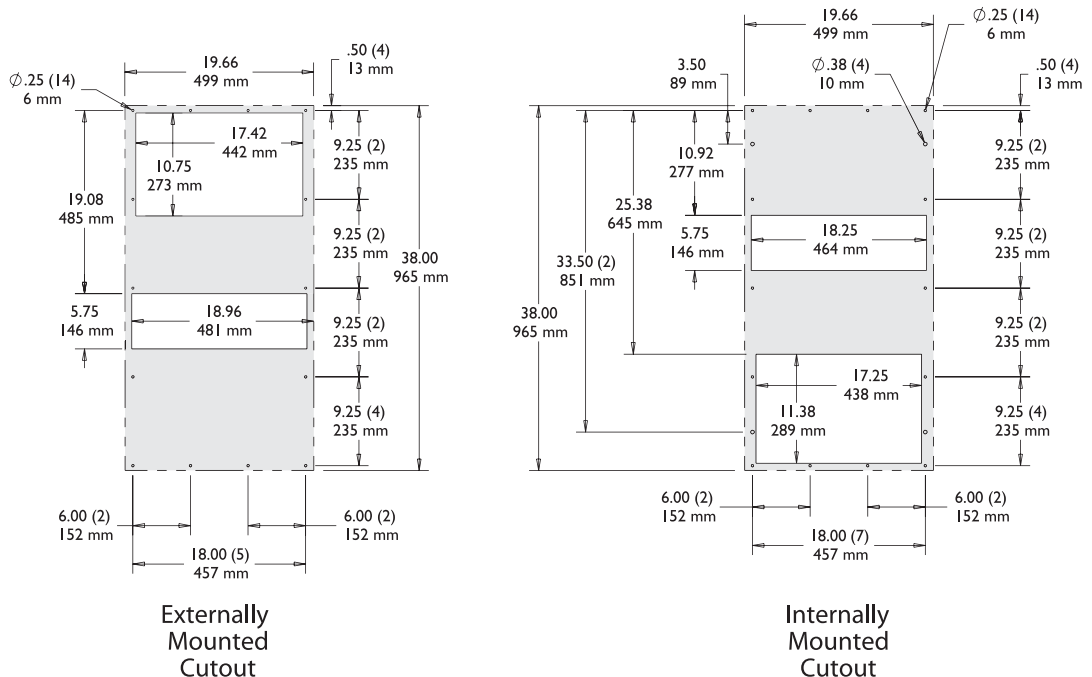

Heat Exchangers

**TX52 Models
For AC Power Supply**

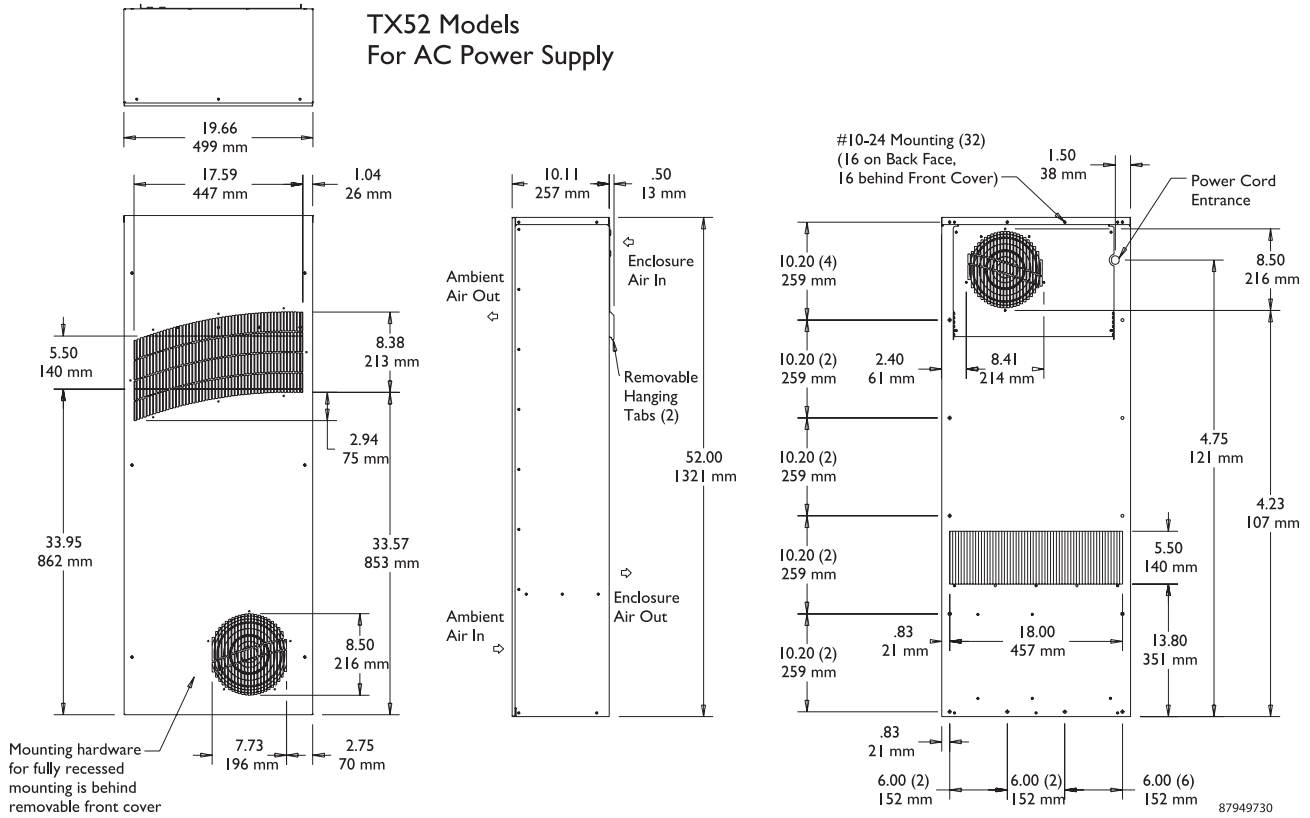

Heat Exchangers

TX52 Models For DC Power Supply

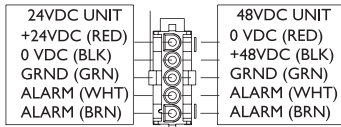
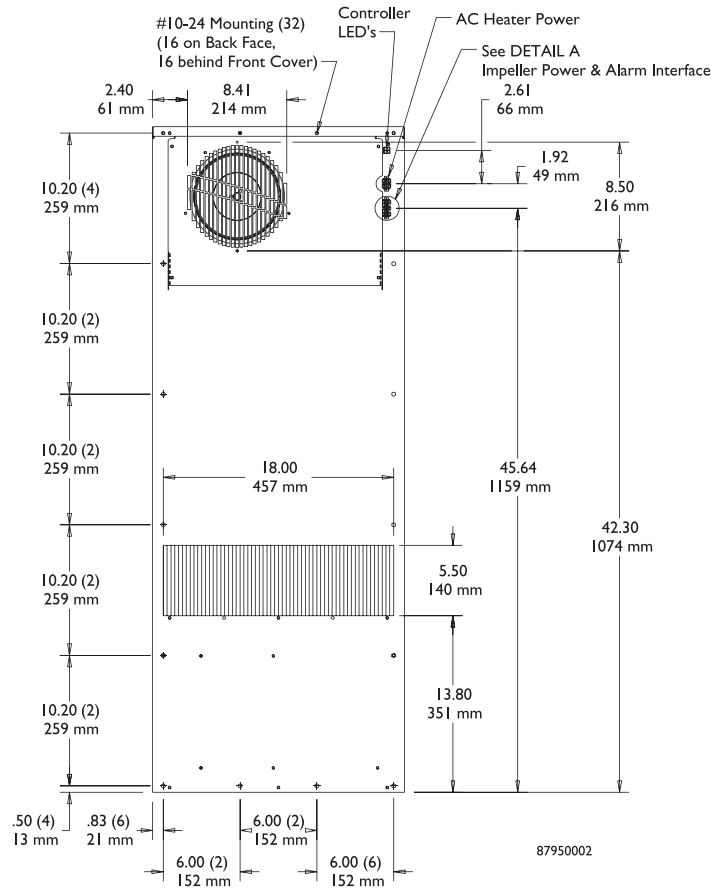
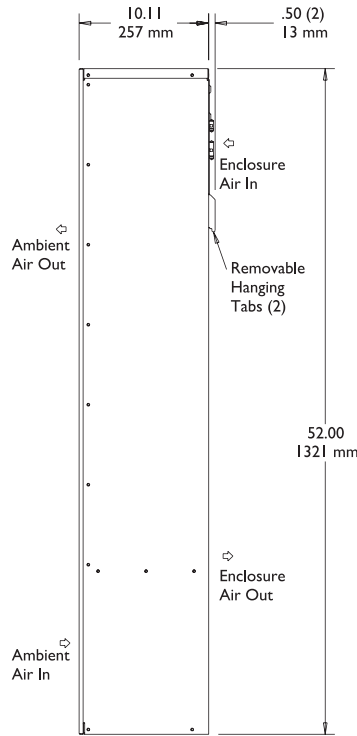

DETAIL A

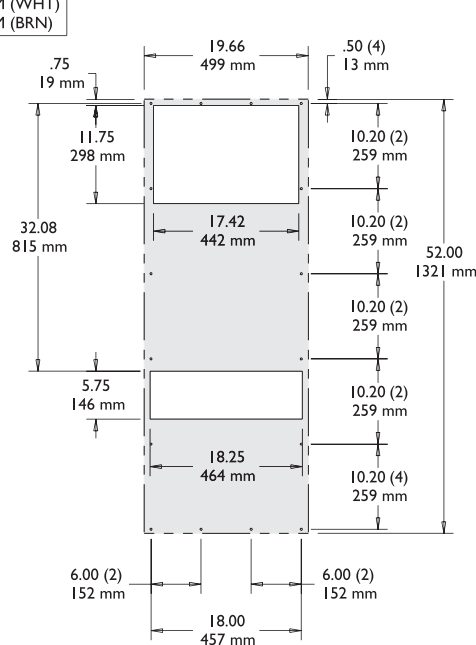

Externally Mounted Cutout

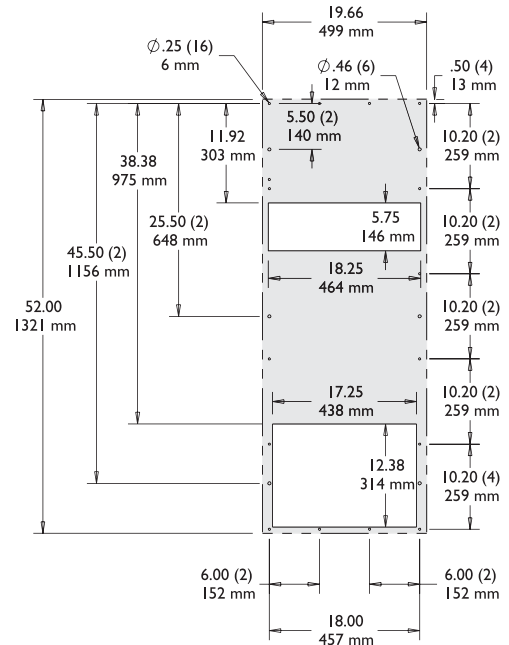

Internally Mounted Cutout

Heat Exchangers

XR Series Compact and Mid-Size Heat Exchanger

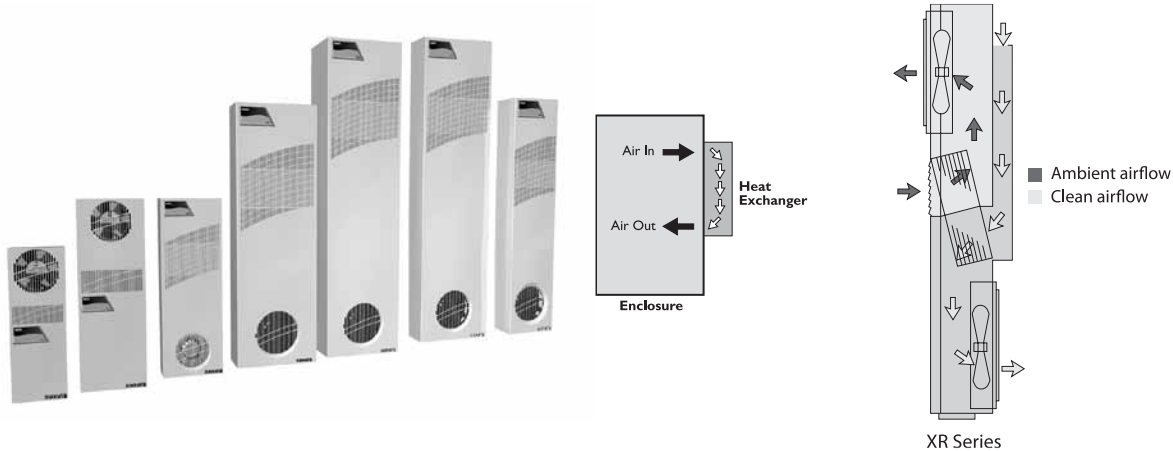

Industry Standards

Maintains UL/cUL Type 12 rating when properly installed on a UL/cUL Type 12 enclosure.

Maintains Type 3R rating when mounted externally and in a vertical position on a UL/cUL Type 3R enclosure.

XR200416012 and XR200426012 do not carry Type 3R rating.

UL/cUL Listed; File No. SA7402

CE

Application

Available in several sizes, these high-efficiency, streamlined heat exchangers are designed for use on narrow or shallow enclosures.

Application Tip

Locate heat-sensitive components in line with the "Air Out" opening of the heat exchanger.

Features

- Unique cores include modified heat pipe core on XR20 and XR2908 and counterflow aluminum core on XR2918, XR47 and XR60
- Top-quality ball-bearing fans
- Streamlined aesthetics with no visible mounting rails or fasteners
- Front cover hinges
- Filterless design; the core slides out for easy cleaning
- Mounts vertically or horizontally on front, side or top of enclosure, inside or outside of enclosure
- Mounting gaskets and instruction manual furnished
- DC voltage available if required. Please contact Hoffman. Service cord provided includes appropriate plug:
 - NEMA 5-15P for 115V units
 - NEMA 6-15P for 230V units

Finish

Coated with RAL 7035 polyester powder paint inside and out

Notes

Hoffman XR units are directly interchangeable with ProAir models.

Bulletin: MCLHE

Standard Product

Catalog Number	AxBxC in.	AxBxC mm	Voltage	Hz	Phase	Full Load Amps	Max Amb. Temp. (°F)	Max Amb. Temp. (°C)	Enclosure Air In (W/°F)	Enclosure Air In (W/K)	Enclosure Air Out (W/°F)	Enclosure Air Out (W/K)	Ship Wt. (lb.)	Ship Wt. (kg)
XR200416012	20.00 x 7.50 x 3.00	508 x 191 x 76	115	50/60	1	0.6	140	60	4	7	9	16	16	7
XR200426012	20.00 x 7.50 x 3.00	508 x 191 x 76	230	50/60	1	0.3	140	60	4	7	9	16	16	7
XR290816012	29.50 x 10.00 x 3.09	749 x 254 x 78	115	50/60	1	0.6	140	60	8	14	30	54	27	12
XR290826012	29.50 x 10.00 x 3.09	749 x 254 x 78	230	50/60	1	0.3	140	60	8	14	30	54	27	12
XR291816012	29.66 x 10.24 x 5.92	753 x 260 x 150	115	50/60	1	1.0	140	60	18	32	34	61	34	16
XR291826012	29.66 x 10.24 x 5.92	753 x 260 x 150	230	50/60	1	0.6	140	60	18	32	34	61	34	16
XR472416012	47.16 x 10.24 x 5.92	1198 x 260 x 150	115	50/60	1	1.5	140	60	24	43	44	79	51	24
XR472426012	47.16 x 10.24 x 5.92	1198 x 260 x 150	230	50/60	1	0.8	140	60	24	43	44	79	51	24
XR473516012	47.16 x 15.24 x 5.92	1198 x 387 x 150	115	50/60	1	1.5	140	60	35	63	77	139	63	29
XR473526012	47.16 x 15.24 x 5.92	1198 x 387 x 150	230	50/60	1	0.8	140	60	35	63	77	139	63	29
XR605516012	59.66 x 15.24 x 5.92	1515 x 387 x 150	115	50/60	1	6.7	140	60	55	99	138	248	91	42
XR605526012	59.66 x 15.24 x 5.92	1515 x 387 x 150	230	50/60	1	3.4	140	60	55	99	138	248	91	42
XR608416012	59.66 x 15.24 x 9.92	1515 x 387 x 252	115	50/60	1	6.7	140	60	84	151	210	378	115	53
XR608426012	59.66 x 15.24 x 9.92	1515 x 387 x 252	230	50/60	1	3.4	140	60	84	151	210	378	115	53

The "enclosure air in" efficiency rating is based on air entering the heat exchanger from the enclosure. The "enclosure air out" efficiency rating is based on air exiting the heat exchanger into the enclosure. All XR exchanger units are rated at 100 F/38 C ambient temperatures with 1500 W internal heat load. Heat exchanger efficiency will decrease as ambient temperature and/or internal heat load decreases.

Heat Exchangers

Mounting Options

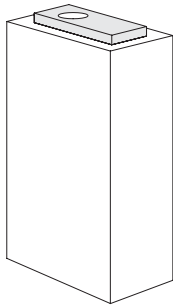

External Top-Mount

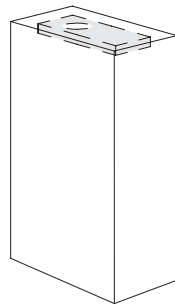

Internal Top-Mount

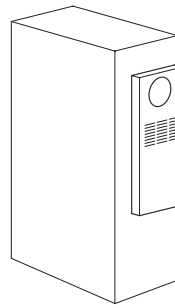

External Vertical-Mount

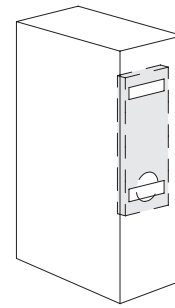

Internal Vertical-Mount

Note:
Internal mounting requires inverting the heat exchanger as shown.

87569532

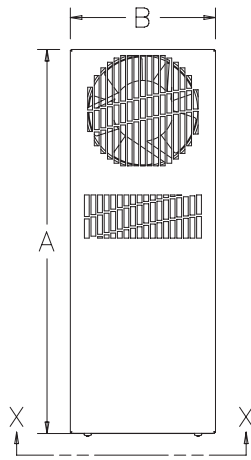

FRONT VIEW

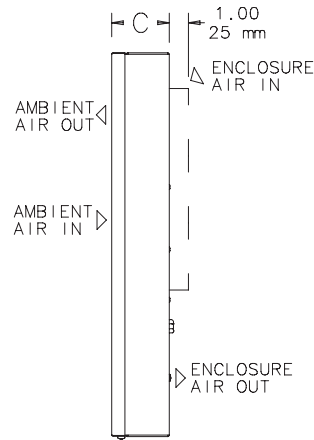

SIDE VIEW

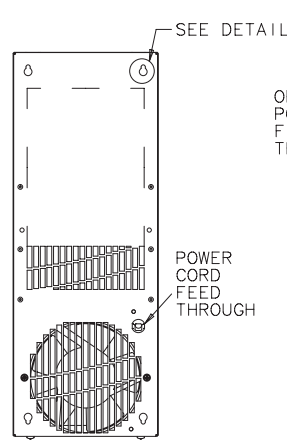

BACK VIEW

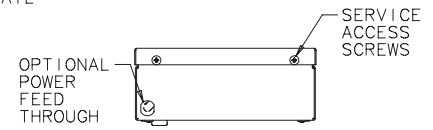

DETAIL X-X

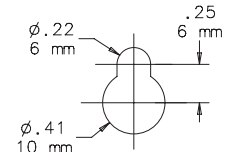

DETAIL

87569500

Note: Detachable airflow plenum can be used when mounting the heat exchanger either inside or outside the enclosure.

Heat Exchangers

XR2918 and XR4724 Heat Exchangers

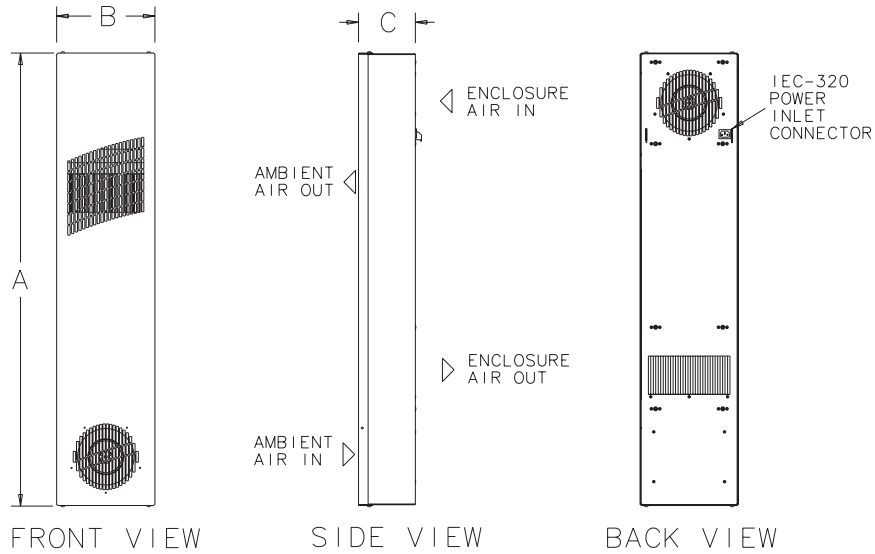

XR4735 and XR60 Heat Exchangers

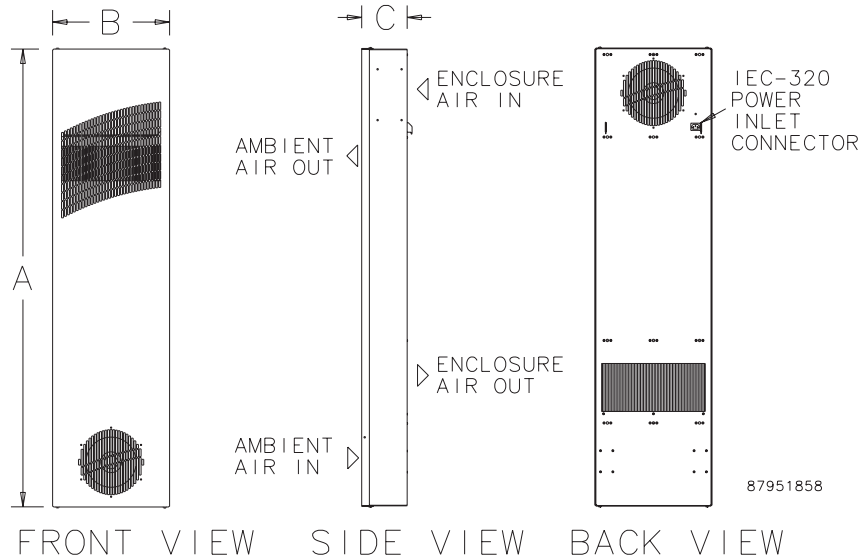

Heat Exchangers

CUTOUTS

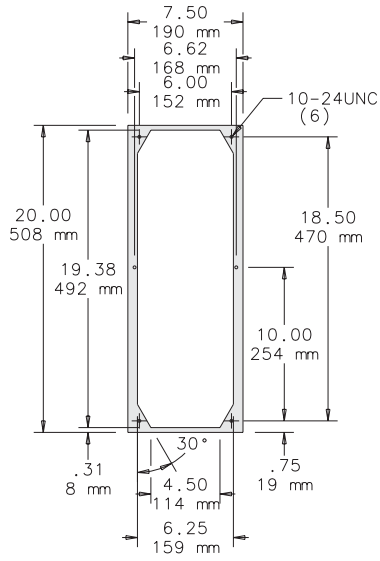

XR20

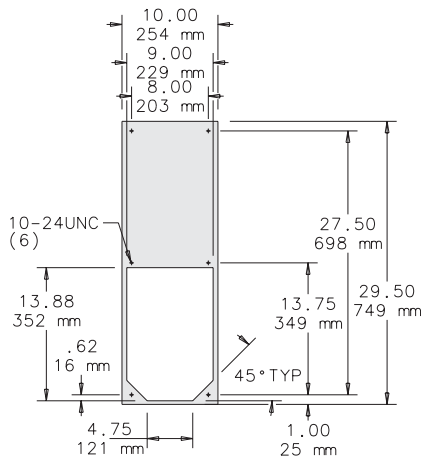

XR29-08

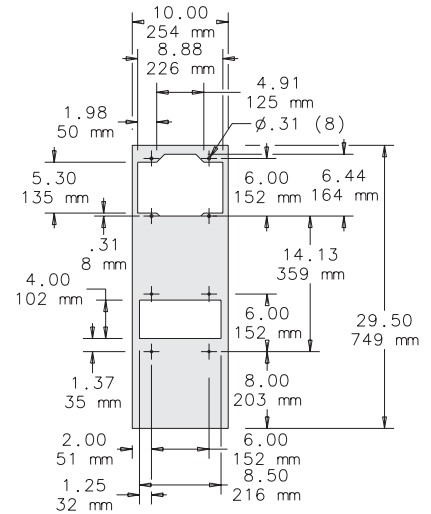

XR2918

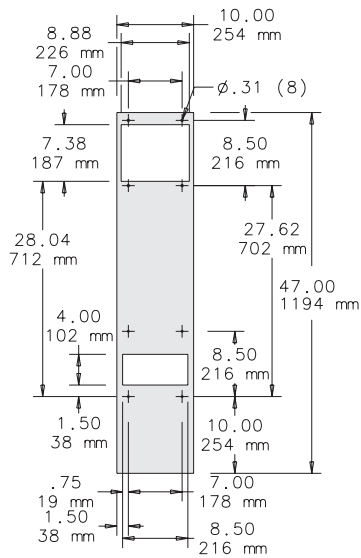

XR4724

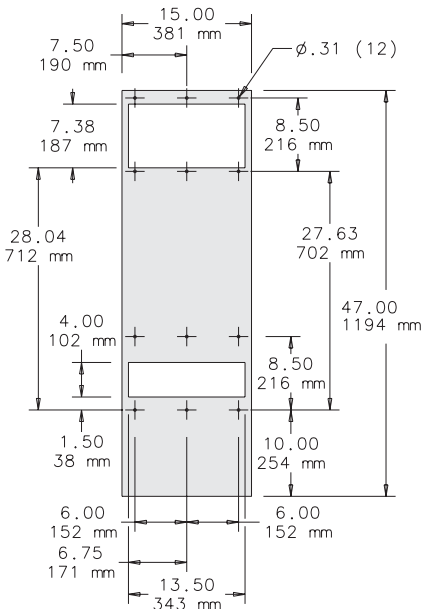

XR4735

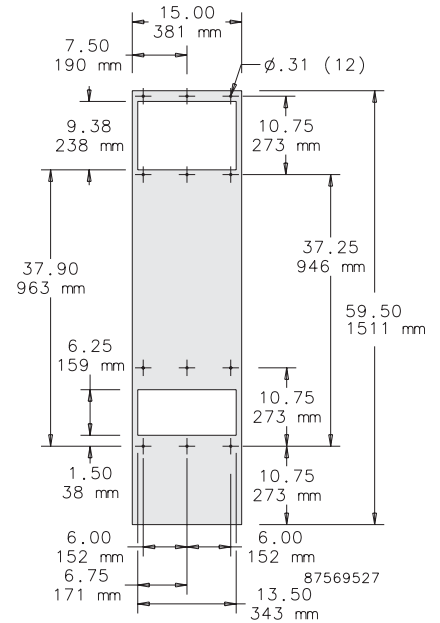

XR60

Notes:

1. Cutouts shown are for external mounting only. For internal mounting, except XR2908, rotate cutout 180 degrees. XR2908 internal mount cutout is not shown.

Fans, Blowers, Louvers and Vents Sizing and Selection

Fans, Blowers, Louvers and Vents Overview

Before choosing a thermal management solution, you need to carefully consider the specifics of your application in addition to the following factors:

- Fan packages and blowers may introduce ambient contaminants like oil mist and dust into the enclosure
- Heat exchangers (this section) cannot cool below the ambient temperature
- Closed-loop air conditioners can cool below ambient temperature and reduce humidity without introducing contaminants
- Simple ventilation devices such as louvers or grilles and filters are appropriate if maintaining a cool, constant temperature is not a critical factor

Once you have determined the proper form of cooling equipment you need, selecting the required cooling capacity is outlined in this section.

Determine the Required Fan/Blower Size (Volume Airflow)

Step 1. Select the product family which best fits your application:

- Compact Cooling Fans (economical fan with no filter)
- Cooling Fan Packages (economical fan package with low-density filter)
- Type 12 Cooling Fan Package
- Filter Fan Packages (high-tech fan package with high-density filter, for IP54 rating)
- Blower Package (centrifugal blower package with filter for densely packed enclosures)

Step 2. Determine the internal heat load in Watts (W).

1 W = 3.413 BTU/Hr.

Step 3. Determine desired temperature difference in degrees F.

Determine the ΔT (F), the temperature difference between the maximum temperature outside the enclosure (T_o) and the maximum desired temperature inside the enclosure (T_i).

$T_o - T_i = \Delta T$ for heat exchangers and fans

NOTE: $1 C \Delta T = 1.8 F \Delta T$

Step 4. Plot your application using the selection graph to the right.

- Find Watts (internal heat load) on the vertical scale
- Draw a horizontal line across to the intersection point with the diagonal line representing your ΔT
- Extend a vertical line down to the horizontal scale to determine your CFM requirement
- Continue the vertical line to identify applicable fan or blower

A sample line is shown in red for a 400 W heat load and a ΔT of 20 F, which indicates a 63 CFM airflow requirement.

Step 5. Make sure the line intersects the bar which includes the exhaust grille kit(s) from the product family chosen in Step 1.

Remember, actual airflow going through your enclosure may be less depending on how densely packed your enclosure is.

Fan output (CFM) is reduced by 10-15% when operated at 50 Hz.

Or calculate using the formula:

$$CFM = (3.16 \times W) / \Delta T (\text{°F})$$

Where:

Watts = Internal Heat Load in Watts

ΔT = Internal Temperature minus Ambient Temperature in °F

CFM = Required airflow in ft.³/min.

Example:

An internal heat load of 400 W requires airflow of about 63 CFM to maintain the enclosure at a ΔT of 20 F above the ambient temperature.

$$CFM = (3.16 \times W) / \Delta T (\text{°F}) \approx 63 \text{ CFM}$$

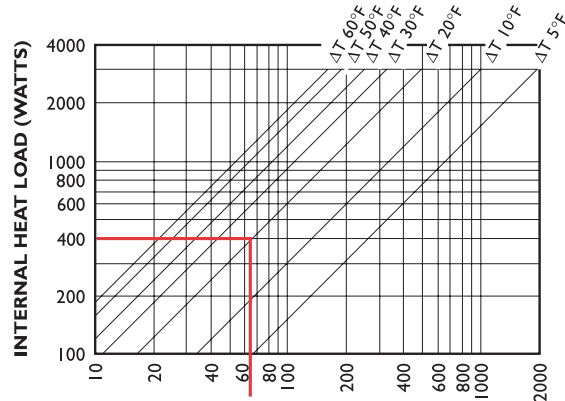

FILTER FAN PACKAGES

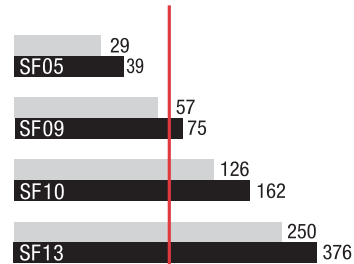

COOLING FAN PACKAGES

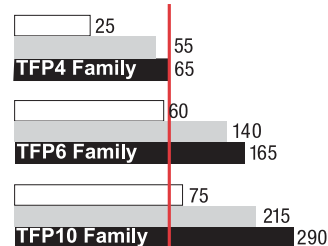

BLOWER PACKAGE



63 CFM

TYPE 12

WITH 1 EXHAUST GRILLE

WITH 2 EXHAUST GRILLES

Fans, Blowers, Louvers and Vents Sizing and Selection

How to Read Filter Fan Package Catalog Numbers

Filter Fans
SF - 05 - 1 - 6 - 001

- SF = Filter fan
- 05 = Approximate size of fan frame (i.e., 05 = 5")
- 1 = 115 Volt, or 2 = 230 Volt
- 6 = 50/60 Hz
- 001 = Standard model

Exhaust Grille Kit
SG - 0500 - 001

- SG = Exhaust grille kit
- 0500 = Approximate size of fan frame (i.e., 05 = 5")
- 001 = Standard model

Thermal Management Sizing and Selection Software



Designed to assist you in determining the most suitable choices of air conditioners, heat exchangers or fans for your application. Download a free copy of our selection software by visiting our web site: hoffmanonline.com. Click on **Thermal Management** chapter.

Cooling Fan and Blower Selection



Cooling Fan Packages

CFM	Cooling Fan Packages
55	TFP41, TFP42
140	TFP61, TFP62
215	TFP101, TFP102

CFM is with one exhaust grille @ 60 Hz.

Filter Fan Packages

CFM	Filter Fan Packages
29	SF05
57	SF09
126	SF10
250	SF13

CFM is with one exhaust grille @ 60 Hz.

Blower Package

CFM	Blower Package
260	ADB275

CFM is with one exhaust grille @ 60 Hz.

Fans, Blowers, Louvers and Vents Sizing and Selection

Compact Cooling Fans



Catalog No.	Diameter in./mm	Square in./mm	Depth in./mm	CFM@60 Hz (M ³ /Hr.)
A4AXFN	—	4.69	1.52	100 (170)
	—	119	39	
A6AXFN	6.72	—	2.00	240 (408)
	171	—	51	
A10AXFN	10.00	—	3.50	560 (951)
	254	—	89	

Cooling Fan Packages

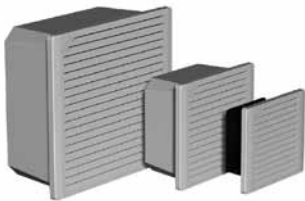

Catalog No.	Diameter in./mm	Square in./mm	Depth in./mm	CFM@60 Hz (M ³ /Hr.)
TFP41	6.29	7.37	2.65	55 (95)
	160	187	67	
TFP61	7.80	8.87	3.75	140 (238)
	198	225	95	
TFP101	11.81	12.99	5.25	215 (370)
	300	330	133	

CFMs with single exhaust grille installed.

Filter Fan Packages



Catalog No.	Diameter in./mm	Square in./mm	Depth in./mm	CFM@60 Hz (M ³ /Hr.)
SF05XXXXXXX	5.83	5.83	2.76	29 (49)
	148	148	70	
SF09XXXXXXX	8.03	8.03	3.76	57 (97)
	204	204	96	
SF10XXXXXXX	9.84	9.84	5.20	126 (214)
	250	250	132	
SF13XXXXXXX	12.72	12.72	6.09	250 (425)
	323	323	155	

CFMs with single exhaust grille installed.

Fans, Blowers, Louvers and Vents Sizing and Selection

Blower Package



Catalog No.	Diameter in./mm	Square in./mm	Depth in./mm	CFM@60 Hz (M ³ /Hr.)
ADB275	5.75 146	19.00 483	7.25 184	230/275 (135/162)

Louvers and Vents

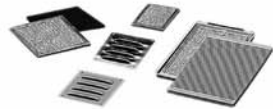

Three styles of louvers and vents provide passive cooling.

Compact Cooling Fans



Can be installed on any surface of an enclosure. With the addition of accessory fan brackets, Compact Cooling Fans can also be installed in any position inside the enclosure for spot cooling or air circulation.

Features

- Maximum operating temperature is 158 F (70 C)
- 4-in. fan is thermally protected and uses permanently lubricated ball bearings
- 6- and 10-in. fans have ball-bearing construction and split-capacitor motors
- Split-capacitor motors are thermally protected to avoid premature failure
- Dynamically balanced impellers molded from polycarbonate material
- One finger guard is furnished (additional finger guards are available)
- All mounting hardware is provided

Fan bracket and additional finger guards must be purchased separately

- 240 and 560 CFM fans have ball bearing construction and split capacitor motors
- Fans have leadwires with ends stripped 1/2-in. (12-mm) or 6-ft. (1.8-m) cord with polarized plug for power connections

Consult your local Hoffman sales office for information on modifications to this product

Industry Standards

UL Component Recognized

CSA certified

Application

Compact Cooling Fans are ideal for applications where enclosure space is limited and quiet, reliable cooling is required. Engineered for 50,000 hours of continuous operation without lubrication or service.

Installation

Finish

Fan housing is black.

Accessories

Fan Brackets
 Finger Guards
 Temperature Control Switch
Bulletin: D85

Standard Product and Cutout Dimensions

Catalog Number	Nominal Size	Power Connection	Voltage	A in./mm	D in./mm	E in./mm	J in./mm	K in./mm	L in./mm	M in./mm
A2AXFN24	2	Lead wires	24 VDC	—	1.97 50	.98 25	1.97 50	.98 25	—	—
A3AXFN	3	Lead wires	115 VAC	—	2.81 71	1.40 36	2.81 71	1.40 36	—	—
A3AXFN24	3	Lead wires	24 VDC	—	2.81 71	1.40 36	2.81 71	1.40 36	—	—
A4AXFNGQ	4	Power cord/Quiet	115 VAC	4.62 117	4.12 105	2.06 52	4.12 105	2.06 52	—	—
A4AXFNPG	4	Power cord	115 VAC	4.62 117	4.12 105	2.06 52	4.12 105	2.06 52	—	—
A4AXFN	4	Lead wires	115 VAC	4.62 117	4.12 105	2.06 52	4.12 105	2.06 52	—	—
A4AXFN2	4	Lead wires	230 VAC	4.62 117	4.12 105	2.06 52	4.12 105	2.06 52	—	—
A4AXFN24	4	Lead wires	24 VDC	4.62 117	4.12 105	2.06 52	4.12 105	2.06 52	—	—
A6AXFNGQ	6	Power cord/Quiet	115 VAC	5.88 149	—	—	—	—	3.19 81	6.38 162
A6AXFNPG	6	Power cord	115 VAC	5.88 149	—	—	—	—	3.19 81	6.38 162
A6AXFN	6	Lead wires	115 VAC	5.88 149	—	—	—	—	3.19 81	6.38 162
A6AXFN2	6	Lead wires	230 VAC	5.88 149	—	—	—	—	3.19 81	6.38 162
A6AXFN24	6	Lead wires	24 VDC	5.88 149	—	—	—	—	3.19 81	6.38 162
A10AXFNPG	10	Power cord	115 VAC	9.00 229	6.88 175	3.44 87	6.88 175	3.4 87	—	—
A10AXFN	10	Lead wires	115 VAC	9.00 229	6.88 175	3.44 87	6.88 175	3.44 87	—	—
A10AXFN2	10	Lead wires	230 VAC	9.00 229	6.88 175	3.44 87	6.88 175	3.44 87	—	—

CFM without exhaust grille

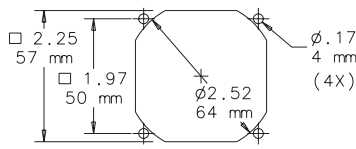
Compact Cooling Fans and Accessories

MOUNTING CUTOUT DIMENSIONS 2 INCH

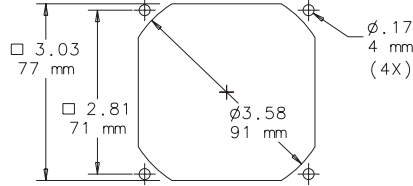

MOUNTING CUTOUT DIMENSIONS 3 INCH

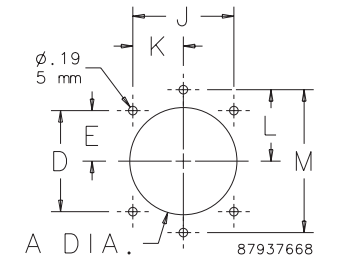

MOUNTING CUTOUT DIMENSIONS 4, 6, 10 INCH

Technical/Performance Data for Compact Cooling Fans

Catalog Number	Nominal Size	Power Connection	Voltage	A @ 50/60 Hz	W @ 50/60 Hz	CFM @ 50/60 Hz	Fan Size (in. ²)	Fan Depth	Max. Motor Operating RPM @	
									50/60 Hz	Noise SIL (dB)
A2AXFN24	2	Lead wires	24 VDC	.09	2.16	21.5	2.36	.98 in.	4550	65
A3AXFN	3	Lead wires	115 VAC	.09	7	27	3.15	1.50 in.	2700	40
A3AXFN24	3	Lead wires	24 VDC	.14	3.36	40	3.15	.98 in.	3400	35
A4AXFNGQ	4 (Quiet Fan)	Power cord	115 VAC	.09/.08	6/5	46/49	4.69	1.52 in.	1350/1450	27/28
A4AXFNPG	4	Power cord	115 VAC	.26/.21	17/15	85/100	4.69	1.52 in.	2415/2900	37/41
A4AXFN	4	Lead wires	115 VAC	.26/.21	17/15	85/100	4.69	1.52 in.	2415/2900	37/41
A4AXFN2	4	Lead wires	230 VAC	.14/.11	16/14	85/100	4.69	1.52 in.	2415/2900	37/41
A4AXFN24	4	Lead wires	24 VDC	.35	84	118	4.69	1.52 in.	3200	46.5
A6AXFNGQ	6 (Quiet Fan)	Power cord	115 VAC	.16/.19	16/18	85/102	6.77	1.50 in.	1400/1650	35/38
A6AXFNPG	6	Power cord	115 VAC	.45/36	36/32	200/240	6.77	1.50 in.	2670/3200	50/56
A6AXFN	6	Lead wires	115 VAC	.45/36	36/32	200/240	6.77	1.50 in.	2670/3200	50/56
A6AXFN2	6	Lead wires	230 VAC	.23/18	39/35	200/240	6.77	1.50 in.	2670/3200	50/56
A6AXFN24	6	Lead wires	24 VDC	.88	21.1	280	6.77	2.00 in.	3750	62.5
A10AXFNPG	10	Power cord	115 VAC	1.0/.88	36/36	480/560	10.00	3.50 in.	1350/1650	45.8/49
A10AXFN	10	Lead wires	115 VAC	1.0/.88	36/36	480/560	10.00	3.50 in.	1350/1650	45.8/49
A10AXFN2	10	Lead wires	230 VAC	.47/43	36/36	480/560	10.00	3.50 in.	1350/1650	45.8/49

Performance Curves: 4-in. Fans

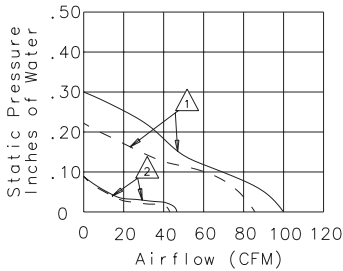

FNPG, FN, FN2 models
 FNGQ models

Performance Curves: 6-in. Fans

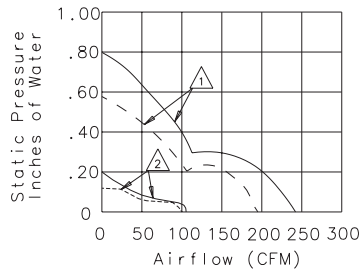

(Curves represent fan performance only.)

Performance Curves: 10-in. Fans

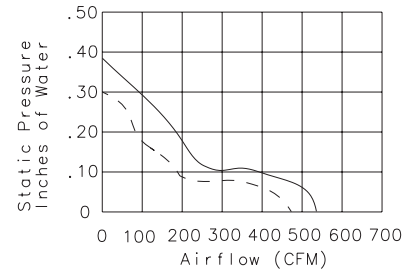

——— 60 Hz
 - - - - - 50 Hz

87744317

Compact Cooling Fans and Accessories

Fan Cords



Used to power Compact Cooling Fans when positive ground of the cabinet case is required. Available with connectors for one or two fans. Five-foot (1.52-meter) cord with grounded three-prong plug. Fits A4AXFNPG, A6AXFNPG, A10AXFNPG, A4AXFNGQ and A10AXFNGQ.

Bulletin: DTHRM

Catalog Number	Description
ACORD1	One connector
ACORD2	Two connectors

Fan Filter and Finger Guard Kit



Low-density filter kit for 4-in. (102-mm) and 6-in. (152-mm) fans. Can also be used as vent. Filter is removable and can be cleaned and reused. Mounting hardware included.

Bulletin: DTHRM, DWS1

Catalog Number	Description	Fits
AFLTR4LD	Fan Filter and Finger Guard Kit	4-in. fans
AFLTR6LD	Fan Filter and Finger Guard Kit	6-in. fans

Compact Cooling Fans and Accessories

Fan Brackets



Designed to provide easy mounting of Hoffman cooling fans on enclosure panels. Brackets can be used for general air circulation or to direct air at problem areas. All sizes are .100-in. aluminum. Package quantity of 1 bracket. Fans must be ordered separately.

Bulletin: D85

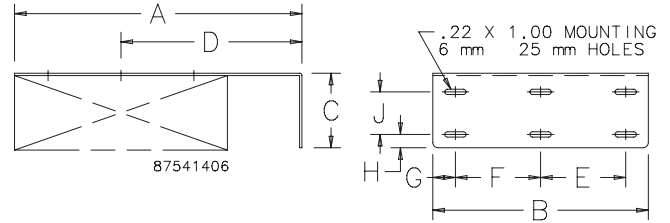

Catalog Number	AxBxC in./mm	Used with Fan Catalog Number	D in./mm	E in./mm	F in./mm	G in./mm	H in./mm	J in./mm
ABRKT2	3.75 x 2.75 x 1.50	A2AXFN24	2.38	—	1.75	.50	.37	.62
	95 x 70 x 38		60	—	44	13	9	16
ABRKT3	4.50 x 3.50 x 1.50	A3AXFN, A3AXFN24	2.75	—	2.50	.50	.37	.62
	114 x 89 x 38		70	—	64	13	9	16
ABRKT4	6.00 x 5.00 x 1.50	A4AXFNPG, A4AXFNGQ, A4AXFN, or A4AXFN2	3.50	—	3.00	1.00	.38	.62
	152 x 127 x 38		89	—	76	25	10	16
ABRKT6	10.00 x 6.88 x 2.00	A6AXFNPG, A6AXFNGQ, A6AXFN, or A6AXFN2	6.50	—	5.00	.94	.38	1.00
	254 x 175 x 51		51	—	127	24	10	25
ABRKT10	13.50 x 10.12 x 3.50	A10AXFNPG, A10AXFNGQ, A10AXFN, or A10AXFN2	8.50	4.00	4.00	1.06	.62	2.00
	343 x 257 x 89		216	102	102	27	16	51

Finger Guards

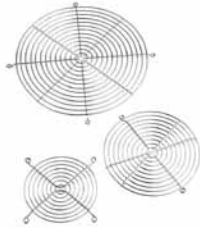

One finger guard is included with each Compact Cooling Fan and Cooling Fan Package. Additional Finger Guards can be mounted on either side of the fan for maximum safety. All guards are chrome-plated and meet UL 507 .25-in. plug gauge test.

Bulletin: D85

Catalog Number	Use on Compact Cooling Fan Catalog Numbers
AGARD2	A2AXFN24
AGARD3	A3AXFN, A3AXFN24
AGARD4	A4AXFNPG, A4AXFNGQ, A4AXFN, A4AXFN2
AGARD6	A6AXFNPG, A6AXFNGQ, A6AXFN, A6AXFN2
AGARD10	A10AXFNPG, A10AXFNQR, A10AXFN, A10AXFN2

Cooling Fan and Exhaust Packages and Accessories

Cooling Fan and Exhaust Packages

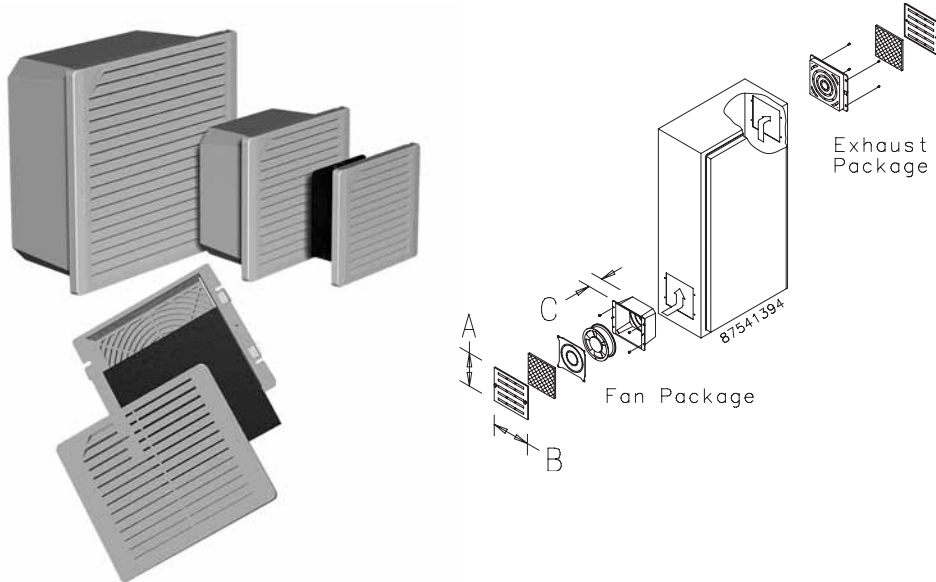

Industry Standards

UL 508A Component Recognized, File Number E61997
TFP# Models: Type 1
TFP# UL 12 Models: Type 12

CSA certified (fan only)
CE

Application

Cooling Fan and Exhaust Packages are designed for limited-space enclosures that require a reliable and filtered airflow. Where positive airflow is not required, Exhaust Packages can be used on both the inlet and outlet.

Engineered for 50,000 hours of continuous operation without lubrication or service. For both Type 1 and Type 12 systems a monthly maintenance schedule is recommended to ensure optimal cooling performance.

Features

- Cooling Fan Package includes fan, air filter, composite air plenum, finger guard and grille
- Exhaust Package includes air filter, filter retainer with integral finger guard and grille
- EMC Upgrade Kit includes a grille standoff collar and a special EMC shielding grille
- Washable foam (Type 1) or disposable (Type 12) filter in fan. Optional washable aluminum air filter is available for Type 1 applications.
- Dynamically-balanced fan impellers molded from polycarbonate material
- 4-in. fan is thermally protected and uses permanently-lubricated ball bearings
- 6- and 10-in. fans have ball bearing construction and split-capacitor motors that are thermally protected to avoid premature failure

- Fans have leadwires for power connection with ends stripped 1/2 in. (12 mm)
- All mounting hardware and installation instructions are furnished

Filters

Standard Type 1 air filters are washable foam.

Type 12 air filters are not washable.

Installation

Fan and exhaust packages can be installed on any surface of an enclosure. They are most effective when the fan assembly is located on a lower panel of the enclosure and the exhaust grille is positioned near the top of the opposite side. This installation assists heat transfer by causing slightly more turbulence and also prolongs the working life of the fan since it is located in the path of the cooler air entering the enclosure.

The height and width of the cooling fans and exhaust grilles can be rotated 90 degrees for mounting on narrow enclosures. Allow adequate clearance for servicing the fan when equipment is installed inside the enclosure and for replacing filters on both the fan and the exhaust. Cutout dimensions for both the fan and the exhaust are shown in the order table. Order the fan and exhaust packages separately.

Finish

Stainless steel grilles have brushed finish.
ABS composite grille is black.

Accessories

Aluminum Type 1 and Hi-Density Type 12 Filters

EMC Upgrade Kit

Grille Options:

- Stainless Steel
- Black ABS Plastic

Bulletin: D85

Cooling Fan and Exhaust Packages and Accessories

Standard Product and Cutout Dimensions **Cooling Fan and Exhaust Packages**

Catalog Number	AxBxC in./mm	Material and Type	Use with Exhaust Grille	Nominal Fan Size	D in./mm	F in./mm	H in./mm	T in./mm	W in./mm
TFP424	6.29 x 7.37 x 2.35 160 x 187 x 67	Composite Grille UL 508 Type 1	TEP4	4	0.45 11	5.66 144	0.77 20	4.12 105	6.39 162
TFP41	6.29 x 7.37 x 2.65 160 x 187 x 67	Composite Grille UL 508 Type 1	TEP4	4	0.45 11	5.66 144	0.77 20	4.12 105	6.39 162
TFP41SS	6.29 x 7.37 x 2.65 160 x 187 x 67	Stainless Steel Grille UL 508 Type 1	TEP4SS	4	0.45 11	5.66 144	0.77 20	4.12 105	6.39 162
TFP41UL12	6.29 x 7.37 x 2.65 160 x 187 x 67	Composite Grille UL 508 Type 12	TEP4UL12	4	0.45 11	5.66 144	0.77 20	4.12 105	6.39 162
TFP42	6.29 x 7.37 x 2.65 160 x 187 x 67	Composite Grille UL 508 Type 1	TEP4	4	0.45 11	5.66 144	0.77 20	4.12 105	6.39 162
TFP42SS	6.29 x 7.37 x 2.65 160 x 187 x 67	Stainless Steel Grille UL 508 Type 1	TEP4SS	4	0.45 11	5.66 144	0.77 20	4.12 105	6.39 162
TFP42UL12	6.29 x 7.37 x 2.65 160 x 187 x 67	Composite Grille UL 508 Type 12	TEP4UL12	4	0.45 11	5.66 144	0.77 20	4.12 105	6.39 162
TFP624	7.80 x 8.87 x 3.75 198 x 225 x 95	Composite Grille UL 508 Type 1	TEP6	6	0.49 12	7.16 182	1.33 34	4.50 114	7.89 200
TFP61	7.80 x 8.87 x 3.75 198 x 225 x 95	Composite Grille UL 508 Type 1	TEP6	6	0.49 12	7.16 182	1.33 34	4.50 114	7.89 200
TFP61SS	7.80 x 8.87 x 3.75 198 x 225 x 95	Stainless Steel Grille UL 508 Type 1	TEP6SS	6	0.49 12	7.16 182	1.33 34	4.50 114	7.89 200
TFP61UL12	7.80 x 8.87 x 3.75 198 x 225 x 95	Composite Grille UL 508 Type 12	TEP6UL12	6	0.49 12	7.16 182	1.33 34	4.50 114	7.89 200
TFP62	7.80 x 8.87 x 3.75 198 x 225 x 95	Composite Grille UL 508 Type 1	TEP6	6	0.49 12	7.16 182	1.33 34	4.50 114	7.89 200
TFP62SS	7.80 x 8.87 x 3.75 198 x 225 x 95	Stainless Steel Grille UL 508 Type 1	TEP6SS	6	0.49 12	7.16 182	1.33 34	4.50 114	7.89 200
TFP62UL12	7.80 x 8.87 x 3.75 198 x 225 x 95	Composite Grille UL 508 Type 12	TEP6UL12	6	0.49 12	7.16 182	1.33 34	4.50 114	7.89 200
TFP101	11.81 x 12.99 x 5.25 300 x 330 x 133	Composite Grille UL 508 Type 1	TEP10	10	0.55 14	11.16 283	2.14 54	6.88 175	11.89 302
TFP101SS	11.81 x 12.99 x 5.25 300 x 330 x 133	Stainless Steel Grille UL 508 Type 1	TEP10SS	10	0.55 14	11.16 283	2.14 54	6.88 175	11.89 302
TFP101UL12	11.81 x 12.99 x 5.25 300 x 330 x 133	Composite Grille UL 508 Type 12	TEP10UL12	10	0.55 14	11.16 283	2.14 54	6.88 175	11.89 302
TFP102	11.81 x 12.99 x 5.25 300 x 330 x 133	Composite Grille UL 508 Type 1	TEP10	10	0.55 14	11.16 283	2.14 54	6.88 175	11.89 302
TFP102SS	11.81 x 12.99 x 5.25 300 x 330 x 133	Stainless Steel Grille UL 508 Type 1	TEP10SS	10	0.55 14	11.16 283	2.14 54	6.88 175	11.89 302
TFP102UL12	11.81 x 12.99 x 5.25 300 x 330 x 133	Composite Grille UL 508 Type 12	TEP10UL12	10	0.55 14	11.16 283	2.14 54	6.88 175	11.89 302

An intake grille and filter are included with each Cooling Fan Package. Order at least one Exhaust Package separately for each installation.

Order optional Exhaust Grilles as a separate accessory.

Fan and Exhaust Grille

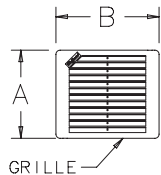

4" Fan
(Fan Mounted to Back of Plenum)

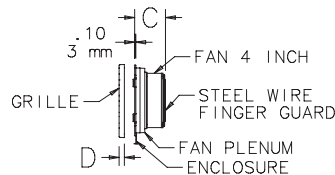

6" and 10" Fan
(Box Style Plenum)

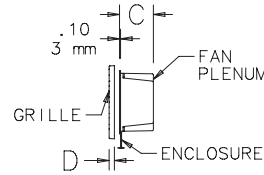

Fan and Exhaust Package
Mounting Cutout

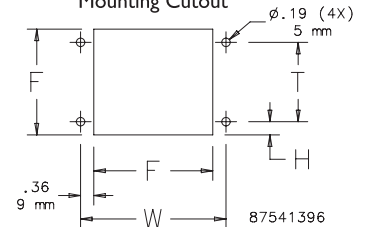

Cooling Fan and Exhaust Packages and Accessories

Technical Performance Data for Cooling Fan Packages

Composite Grille UL Type 1	Stainless Grille UL Type 1	Type 1 CFM @ 50/60 Hz	Composite Grille UL Type 12	Type 12 CFM @ 50/60 Hz	W @ 50/60 Hz	A @ Voltage	Max. Operating Temperature (°F)	Max. Operating Temperature (°C)	Noise SIL (dB) @ 50/60 Hz	Weight (lb.)	Weight (kg)
TFP424	—	55	—	—	8.4	24 VDC	158	70	65	4.2	1.90
TFP41	TFP41SS	46/55	TFP41UL12	21/25	17/15	115 VAC	158	70	37/41	4.2	1.90
TFP42	TFP42SS	46/55	TFP42UL12	21/25	16/14	230 VAC	158	70	37/41	4.3	1.95
TFP624	—	140	—	—	21.1	24 VDC	158	70	62.5	5.3	2.40
TFP61	TFP61SS	117/140	TFP61UL12	50/60	36/32	115 VAC	158	70	50/56	5.3	2.40
TFP62	TFP62SS	117/140	TFP62UL12	50/60	39/35	230 VAC	158	70	50/56	5.4	2.45
TFP101	TFP101SS	180/215	TFP101UL12	63/75	64/80	115 VAC	167	75	54/61	12.0	2.45
TFP102	TFP102SS	180/215	TFP102UL12	63/75	64/80	230 VAC	167	75	54/61	11.4	5.17

CFM with single exhaust grille installed.

Performance Curve for a 4" Cooling Fan Package @ 60 Hz

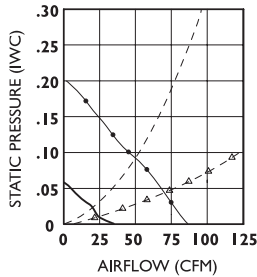

- 4 in. Cooling Fan Package
- - - 4 in. Exhaust Package
- -△- - Two 4 in. Exhaust Packages
- 4 in. Type 12 Cooling Fan Package

Performance Curve for a 6" Cooling Fan Package @ 60 Hz

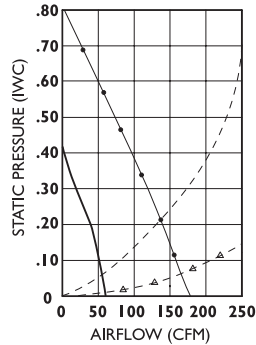

- 6 in. Cooling Fan Package
- - - 6 in. Exhaust Package
- -△- - Two 6 in. Exhaust Packages
- 6 in. Type 12 Cooling Fan Package

Performance Curve for a 10" Cooling Fan Package @ 60 Hz

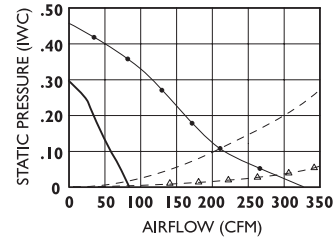

- 10 in. Cooling Fan Package
- - - 10 in. Exhaust Package
- -△- - Two 10 in. Exhaust Packages
- 10 in. Type 12 Cooling Fan Package

Cooling Fan and Exhaust Packages and Accessories

Exhaust Grilles

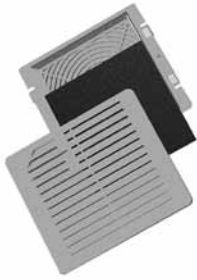

Bulletin: D85

Catalog Number	Nominal Fan Size
TEP4	4 in.
TEP4SS	4 in.
TEP4UL12	4 in.
TEP6	6 in.
TEP6SS	6 in.
TEP6UL12	6 in.
TEP10	10 in.
TEP10SS	10 in.
TEP10UL12	10 in.

Optional Grilles and Replacement Filters

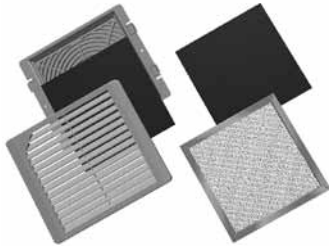

Optional grilles offer the choice of stainless steel or black ABS plastic. These grilles replace the standard RAL 7035 gray composite or stainless steel grilles on both fan and exhaust packages. Standard replacement filters are washable foam (Type 1) or disposable (Type 12). To maintain UL Type 12 rating on the enclosure, UL Type 12 filters must be used on the fan package inlet. Washable aluminum filters are also available. Aluminum filters are compatible with Type 1 systems only.

Type 12 air filters are not washable.

Bulletin: D85

Catalog Number	Description	Fits Fan and Exhaust Nominal Size	Fits Fan and Exhaust Grill Size (in.)	Fits Fan and Exhaust Grille Size (mm)
TG4SS	Brushed stainless steel grille	4	6.29 x 7.31 x .81	(160 x 186 x 21)
TG4B	Black ABS plastic grille	4	6.29 x 7.37 x .81	(160 x 187 x 21)
AFLTR4	Type 1 filter replacement (5/package)	4	—	—
AFLTR4AL	Aluminum filter replacement (5/package)	4	—	—
TFLT4UL12	Type 12 filter replacement (5/package)	4	—	—
TG6SS	Brushed stainless steel grille	6	7.80 x 8.81 x .75	(198 x 224 x 19)
TG6B	Black ABS plastic grille	6	7.80 x 8.87 x .49	(198 x 225 x 12)
AFLTR6	Foam filter replacement (5/package)	6	—	—
AFLTR6AL	Aluminum filter replacement (5/package)	6	—	—
TFLT6UL12	UL 12 filter replacement (5/package)	6	—	—
TG10SS	Brushed stainless steel grille	10	11.81 x 12.92 x .75	(300 x 328 x 19)
TG10B	Black ABS plastic grille	10	11.81 x 12.99 x .75	(300 x 330 x 19)
AFLTR10	Foam filter replacement (5/package)	10	—	—
AFLTR10AL	Aluminum filter replacement (5/package)	10	—	—
TFLT10UL12	UL 12 filter replacement (5/package)a	10	—	—

Replacement filter for Type 12 fan package only (models TFF___UL12). For Type 12 exhaust package use replacement filter AFLTRX.

Filters fit all fan and exhaust packages according to their size.

EMC Fan/Grille Upgrade Kit

With the addition of this kit, the cooling fan and exhaust packages are upgraded to provide EMC (electromagnetic compatibility) protection. Consult Hoffman for shielding effectiveness (dB attenuation vs. frequency).

Separate kits must be installed on both the inlet and outlet. Cooling fan and exhaust package must be ordered separately. EMC upgrade kit will not work with stainless steel grille option.

Bulletin: D85

Catalog Number	Fits Cooling Fan Package	Fits Exhaust Grille
T4EMC	TFP41/TFP42	TEP4
T6EMC	TFP61/TFP62	TEP6
T10EMC	TFP101/TFP102	TEP10

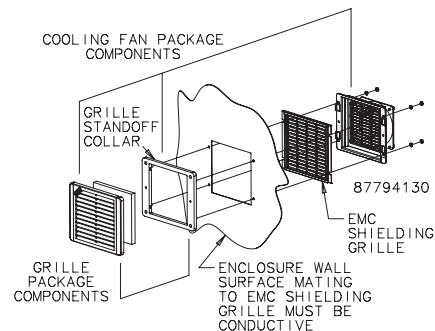

How to Choose a Filter Fan

How to Choose a Filter Fan Overview

Three overall considerations are applied when selecting a filter fan:

- voltage input
- enclosure protection
- airflow requirement

Voltage Input

Narrowing the choice of filter fans based on voltage input is quite simple. If the voltage available in the electronics system to power the filter fan is AC, then a VAC filter fan is chosen. If the voltage for the application is DC, then a VDC filter fan is specified.

The voltage level of the filter fan's power input also needs to be taken into consideration. For example, if the voltage input is 115 VAC, then a 115 VAC filter fan should be specified. If the voltage input is 24 VDC, then a 24 VDC impeller is required. Filter fans are commonly available in 115, 230 and 460 3-phase 50/60 Hz VAC as well as 24 VDC. Some manufacturers such as Pentair Technical Products offer 48 VDC due to the trend toward using this power input in some electronic systems.

Enclosure Protection

Another important consideration is selecting a filter fan and exhaust grille that maintains the protection level of the electrical enclosure.

U.S. standards of protection generally include:

Type 1 – For indoor use to protect against contact with the enclosed equipment

Type 12 – For indoor use to protect against dust, falling dirt and dripping non-corrosive liquid such as water

Type 3R – For outdoor use to protect against rain and sleet

Type 4 – For outdoor or indoor use to protect against windblown dust and rain, splashing water and hose-directed water

Type 4X – For outdoor or indoor use to protect against corrosion, windblown dust and rain, splashing water and hose-directed water

European standards of protection include:

IP54 – Dust must not enter in sufficient quantity to interfere with the satisfactory operation of the equipment, complete protection against contact; water splashing against the enclosure from any direction shall have no harmful effect.

IP55 – Dust must not enter in sufficient quantity to interfere with the satisfactory operation of the equipment, complete protection against contact; and water projected by a nozzle against enclosure from any direction shall have no harmful effects.

IP65 – No ingress of dust; complete protection against contact; and water projected by a nozzle against enclosure from any direction shall have no harmful effects.

Airflow

Choosing a filter fan with the right airflow or cooling capacity is as important as voltage input and enclosure protection. However, the process is a little more involved.

Generally, smaller heat loads in the electronics system will require a filter fan with a lower airflow rate (CFM or M³/Hr.). Moderate to high heat loads will need a larger, more powerful filter fan or multiple filter fans to move enough air to cool the electronics components.

The following 5-step process results in a filter fan specification that should generally work in your electronics system.

1. Determine Delta-T
2. Determine Internal Heat Load
3. Determine Free Airflow
4. Estimate System Impedance
5. Select Your Filter Fan

These five steps yield a ballpark result. A filter fan sample should always be tested in the actual electrical system itself to confirm that its performance provides adequate airflow.

The next section outlines the 5-step filter fan selection process in more detail.

How to Derive Filter Fan Airflow

Step 1. Determine Delta-T (ΔT)

Delta-T is the difference between **maximum desired temperature for the electronics** and **maximum temperature outside the enclosure**. It is important to determine ΔT because cooler air will usually require less filter fan airflow whereas warmer air will typically require more airflow.

Maximum desired temperature for the electronics is identified by reviewing the component manufacturer's specifications. They will often indicate that the equipment should not operate above a certain temperature such as 35 C (95 F).

Maximum temperature **outside the enclosure** is determined by forecasting the highest potential temperature of the air around the electronics cabinet. If the application is in an indoor environment such as an air conditioned factory, the maximum temperature outside the enclosure is the temperature of the facility, such as 25 C (77 F). If the electronics system is outdoors, the maximum temperature around the cabinet is the hottest weather that the application experiences, which may be 45 C (116 F) if it's deployed on a roof top for example.

$\Delta T =$
 maximum temperature desired for the electronics -
 maximum expected ambient temperature

For example:

$\Delta T =$
 35 C (95 F) [maximum electronics temperature] -
 25 C [maximum ambient temperature]
 $\Delta T = 10 C (18 F)$

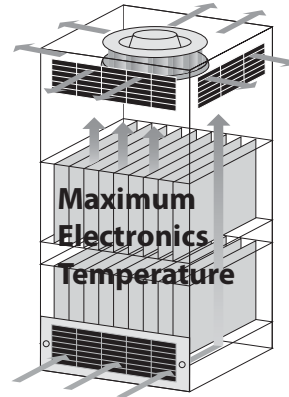

**Maximum
Ambient
Temperature**

Step 2. Determine Internal Heat Load

Heat load stems from the amount of waste heat generated inside the enclosure by the electronic components and is expressed in Watts. There are several methods to determine internal heat load, depending on data availability.

A. Heat Load Data from Each Electronics Component Manufacturer

One way to estimate internal load is to gather heat load data from the manufacturers of the electronics components inside the cabinet. If more than one control or other components are inside the enclosure, it will be necessary to add together the multiple estimates of heat load to determine total internal heat load.

B. Component Power – Component Efficiency

A second method is to establish the Watts of power used by each electronic component. Derive Watts by multiplying the amp draw of each device with its voltage. Then subtract the efficiency of each component from its estimated power use, adding up the outcomes for total internal heat load.

INTERNAL HEAT LOAD =
 COMPONENT POWER (W) - COMPONENT EFFICIENCY
 (for each electrical device)

For example:

An electronic system uses two components that draw 115 VAC at 9.5 A. Each has a rated efficiency of 90 percent (10 percent of each device is inefficient). Unused amounts of power become generated heat. Thus, the estimated internal heat load is:

Device Power = 115 x 9.5 = 1100 W
 Total Power = 2 x 1100 = 2200 W
 Less Efficiency = 2200 x (1 - .90)
 Total Heat Load = 220 W

C. Incoming – Outgoing Power

A third approach is to estimate the power going into the enclosure and the power coming out of it. The difference is the estimated amount of internal heat load. Multiply the amps and volts of each electrical line going in to determine Watts and then add them together. Do the same for the electrical line(s) coming out of the application. The outgoing watts are subsequently subtracted from the incoming watts.

INTERNAL HEAT LOAD =
 INCOMING POWER (W) – OUTGOING POWER (W)

For example:

An enclosure has three input lines of 230 VAC at 11, 6 and 4 A. It has one output control line of 115 VAC at 9 A.

Incoming Power = (230 x 11) + (230 x 6) + (230 x 4) = 4830 W

Outgoing Power = (115 x 9) = 1035 W

Total Heat Load = 4830 – 1035 = 3795 W

D. Automated Equipment Horsepower

The fourth method applies only to industrial automation equipment that operates with horsepower such as variable frequency drives (VFDs). 1 hp = 745.6 W. Thus, the internal heat load from a 3 hp VFD is 2237 W, less its efficiency which is typically 93 – 95 percent.

For example:

A cabinet has three 5 hp VFDs with 95% efficiency.

VFD Watts = 5 hp x 745.6 x 3 = 11184

Adjusted Watts = 11184 x (1 - .95) = 559

Total Heat Load = 559 x 1.25 = 699 W

Note: 1.25 is an assumed "safety" margin for other minor heat-producing components.

How to Derive Filter Fan Airflow

Step 3. Determine Free Airflow

Determining free airflow applies the results from steps 1 and 2 to the chart below. Recall that free airflow is the unimpeded airflow through the enclosure without any interference from electronics components or filter fan exhaust grilles.

Select the diagonal ΔT line that closely matches the ΔT of your electronics system. Using the example from step 1, ΔT is 10 C (18 F).

Then find your cabinet's heat load along the Y-axis of the chart. In the example from step 2, heat load is 2000 W.

Find where heat load intersects with ΔT to determine free airflow on the X-axis. Continuing the example, free airflow in this case is 360 CFM or 611 M³/Hr.

Now we need to account for system impedance, i.e., the amount of airflow interference created by the electronic components inside the cabinet. A filter fan with **more than** 360 CFM or 611 M³/Hr. of free airflow will actually be needed for this system's design.

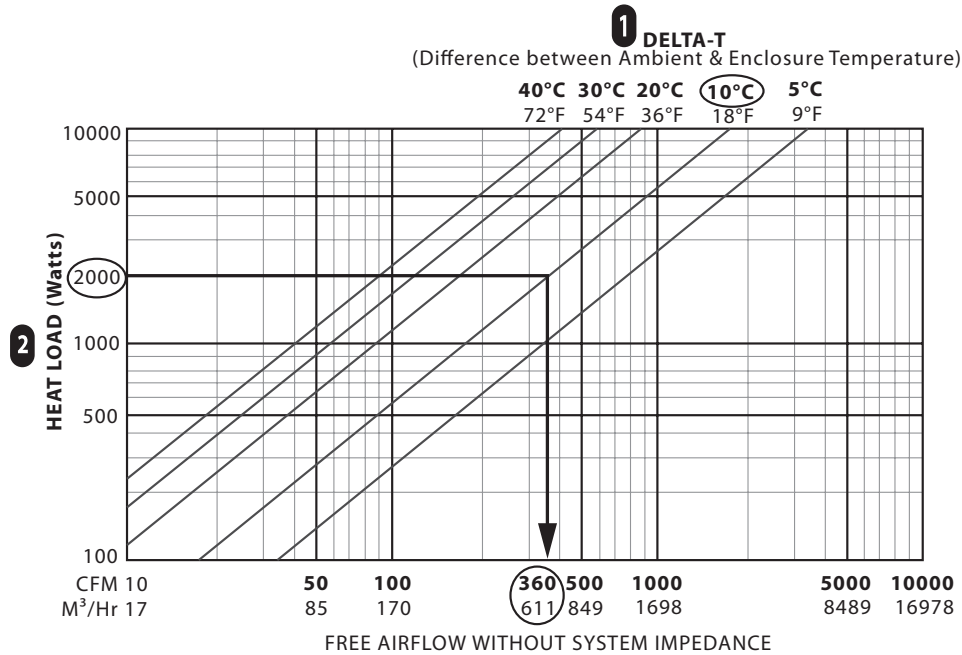

How to Derive Filter Fan Airflow

Step 4. Estimate System Impedance

Static pressure or system impedance can impact the cooling performance of an air mover. Filter fans work well in electrical cabinets with low static pressure such as a large enclosure with a bare drive and few other components. They do not have enough force to push air through a cabinet with a moderate or high system impedance.

If your system design appears like the middle or right hand example, then a motorized impeller or blower is probably a better solution for the application than a filter fan.

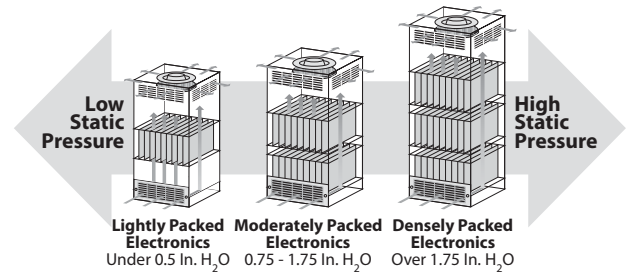

Assuming a filter fan can cool your application, the exhaust grille and electrical components inside the enclosure will reduce airflow through the system. Filter fan manufacturers will show the effect of the exhaust grille on the performance curve. However, they do not indicate the impedance curve of the electronics system because filter fan makers do not know this information. Only the specifying electronics engineer or system designer can determine this. If it is not possible to measure the exact static pressure inside an electronics cabinet, you must make an estimate and draw an approximation.

In the example shown, the free airflow of a 376 CFM (638 M³/Hr.) filter fan decreases to 265 CFM with the exhaust grille kit and down to 180 CFM when used in an actual application. Thus, a filter fan model with a performance curve similar to the one in the next graph would be too small to keep our electrical system cool because our actual target airflow is 360 CFM.

Impact of System Impedance on Free Airflow of a 376 CFM (638 M³/Hr.) Filter Fan

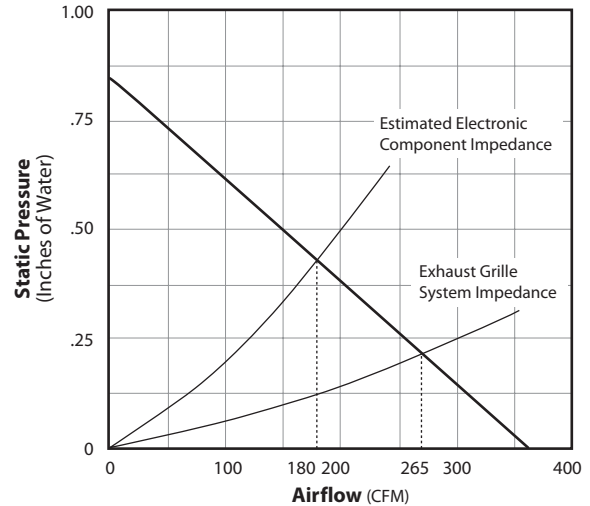

Step 5. Select Your Filter Fan

In this final step, we bring together the results of free airflow (step 3) and system impedance (step 4), using the filter fan performance charts. Applying the example, we need to select a motorized impeller that delivers a minimum of 360 CFM (611 M³/Hr.).

Identify alternative filter fan models with free airflow ratings that are greater than the step 3 outcome of 360 CFM (611 M³/Hr.) to compensate for airflow losses created by static pressure in the system. A judgmental system impedance curve is overlaid onto the performance charts of each of the optional filter fans, and then the model with the CFM or M³/Hr. closest to the target airflow is selected.

In the performance curve shown here, 571 CFM is commonly the largest filter fan in the electronics cooling industry. Based on the estimated electronic component impedance overlaid by our imaginary engineer, it should deliver the cooling performance required by the system.

Performance Curve of a 571 CFM (969 M³/Hr.) Filter Fan Exhaust Grille and Estimated System Impedance

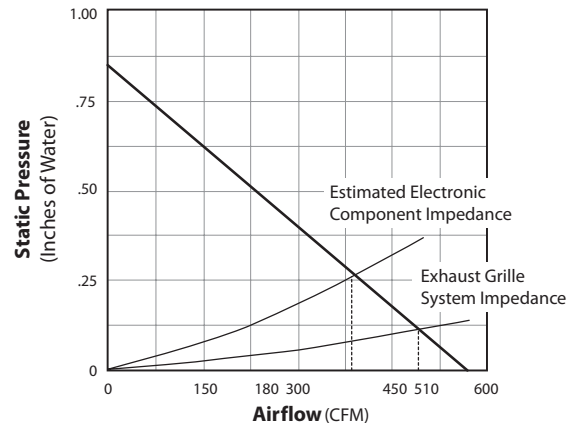

A Friendly Reminder

This 5-step process for selecting a filter fan yields a ballpark result. Be sure to test a sample of the filter fan in the electrical system prototype at maximum ambient and heat load conditions to verify adequate cool airflow.

SF04 16 CFM (28 m³/hr.) Side-Mount Filter Fan



Features

- Free airflow up to 16 CFM (28 m³/hr.)
- Approximate size 4 in. (105 mm)
- Click-fit design quickly installs into enclosure wall; no tools or screws required
- Enclosure side wall mounting
- Standard foam-in-place gasket
- Similar cut-out sizes as other filter fan manufacturers
- Terminal wire connections
- Simple snap-open grille for easy filter replacement

Finish

- RAL 7035 light-gray, UV-resistant plastic standard
- RAL 9011 black, UV-resistant plastic optional

Notes

Order Exhaust Grille Kits separately.

Bulletin: MCL

Industry Standards

UL/cUL recognized, CE, CSA (fan motor only)

Type 12, IP54 standard

Performance Data SF04 16 CFM (28 m³/hr.) Side-Mount Filter Fan

Catalog Number	AxBxCin./mm	NEMA/ IP Rating	Color	Volt	Hz	Phase	Full Load Amps	Motor RPM	Low Temp. °F/°C	High Temp. °F/°C	Noise dB(A)	Ship Wt. (lb./kg)	Free Airflow CFM (m ³ /hr.)	Free Airflow with 1 Exhaust Grille (m ³ /hr.)
SF0424414H	4.13 x 4.13 x 2.17 105 x 105 x 55	Type 12 / IP54	7035	24	NA	1	1.00	3300	-4/-20	149/65	36	.73/33	16 (28)	10 (17)
SF0424413H	4.13 x 4.13 x 2.17 105 x 105 x 55	Type 12 / IP54	9011	24	NA	1	1.00	3300	-4/-20	149/65	36	.73/33	16 (28)	10 (17)
SF0448414H	4.13 x 4.13 x 2.17 105 x 105 x 55	Type 12 / IP54	7035	48	NA	1	.54	3300	-4/-20	149/65	36	.73/33	16 (28)	10 (17)
SF0448413H	4.13 x 4.13 x 2.17 105 x 105 x 55	Type 12 / IP54	9011	48	NA	1	.54	3300	-4/-20	149/65	36	.73/33	16 (28)	10 (17)
SF0416414H	4.13 x 4.13 x 2.17 105 x 105 x 55	Type 12 / IP54	7035	115	50/60	1	1.40/1.20	2700/3200	14/-10	131/55	30	1.08/49	16 (28)	10 (17)
SF0416413H	4.13 x 4.13 x 2.17 105 x 105 x 55	Type 12 / IP54	9011	115	50/60	1	1.40/1.20	2700/3200	14/-10	131/55	30	1.08/49	16 (28)	10 (17)
SF0426414H	4.13 x 4.13 x 2.17 105 x 105 x 55	Type 12 / IP54	7035	230	50/60	1	.70	2700/3200	14/-10	131/55	30	1.12/51	16 (28)	10 (17)
SF0426413H	4.13 x 4.13 x 2.17 105 x 105 x 55	Type 12 / IP54	9011	230	50/60	1	.70	2700/3200	14/-10	131/55	30	1.12/51	16 (28)	10 (17)

Order Exhaust Grille Kit separately.

Filter Fan Packages

SF04 16 CFM (28 M³/Hr.) Side-Mount Filter Fan
Performance Curve

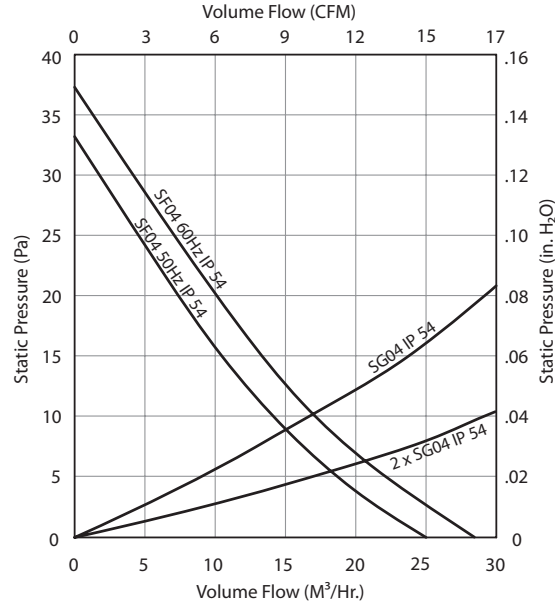

FILTER FAN

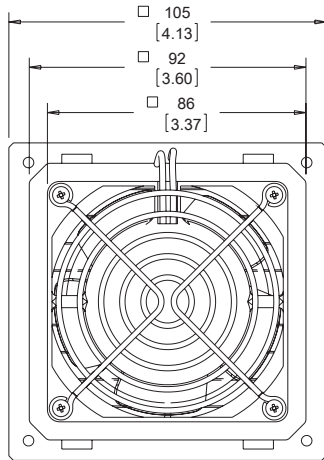

BACK VIEW

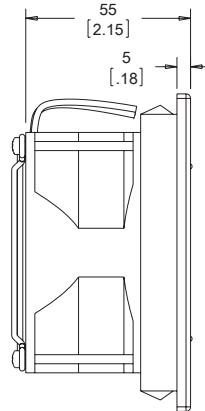

SIDE VIEW

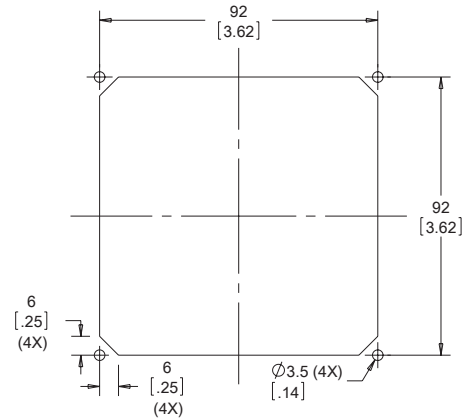

CUTOUT

EXHAUST GRILLE

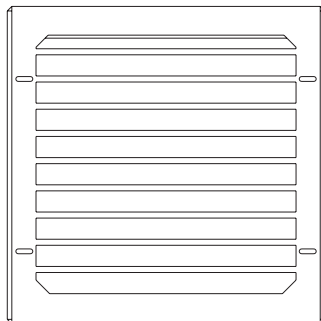

Order Exhaust Grille Kits separately

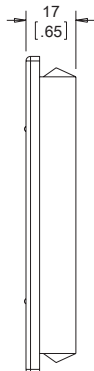

89051142

SF05 39 CFM (66 m³/hr.) Side-Mount Filter Fan



Features

- Free airflow up to 39 CFM (66 m³/hr.)
- Approximate size 5 in. (148 mm)
- Click-fit design quickly installs into enclosure wall; no tools or screws required
- Enclosure side wall mounting
- Standard foam-in-place gasket
- Similar cut-out sizes as other filter fan manufacturers
- Terminal wire connections
- Simple snap-open grille for easy filter replacement

Finish

- RAL 7035 light-gray UV-resistant plastic standard
- RAL 9011 black UV-resistant plastic optional

Notes

Order Exhaust Grille Kits separately.

Bulletin: MCL

Industry Standards

UL/cUL recognized, CE, CSA (fan motor only)

Type 12, IP54 standard

Type 12, IP55 optional

Performance Data SF05 39 CFM (66 m³/hr.) Side-Mount Filter Fan

Catalog Number	AxBxCin./mm	NEMA/ IP Rating	Color	Volt	Hz	Phase	Full Load Amps	Motor RPM	Low Temp. °F/°C	High Temp. °F/°C	Noise dB(A)	Ship Wt. (lb./kg)	Free Airflow CFM (m ³ /hr.)	Free Airflow with 1 Exhaust Grille (m ³ /hr.)
SF0524414H	5.83 x 5.83 x 2.56 148 x 148 x 65	Type 12 / IP54	7035	24	NA	1	.17	3050	-4/-20	149/65	42	1.19/.51	39 (66)	26 (44)
SF0524413H	5.83 x 5.83 x 2.56 148 x 148 x 65	Type 12 / IP54	9011	24	NA	1	.17	3050	-4/-20	149/65	42	1.19/.51	39 (66)	26 (44)
SF0548414H	5.83 x 5.83 x 2.56 148 x 148 x 65	Type 12 / IP54	7035	48	NA	1	.08	3050	-4/-20	149/65	42	1.19/.51	39 (66)	26 (44)
SF0548413H	5.83 x 5.83 x 2.56 148 x 148 x 65	Type 12 / IP54	9011	48	NA	1	.08	3050	-4/-20	149/65	42	1.19/.51	39 (66)	26 (44)
SF0516414H	5.83 x 5.83 x 2.56 148 x 148 x 65	Type 12 / IP54	7035	115	50/60	1	.23	2650/3100	14/-10	131/55	42	1.76/.80	39 (66)	26 (44)
SF0516413H	5.83 x 5.83 x 2.56 148 x 148 x 65	Type 12 / IP54	9011	115	50/60	1	.23	2650/3100	14/-10	131/55	42	1.76/.80	39 (66)	26 (44)
SF0526413H	5.83 x 5.83 x 2.56 148 x 148 x 65	Type 12 / IP54	9011	230	50/60	1	.11	2650/3100	14/-10	131/55	42	1.76/.80	39 (66)	26 (44)
SF0524514H	5.83 x 5.83 x 2.56 148 x 148 x 65	Type 12 / IP55	7035	24	NA	1	.17	3050	-4/-20	149/65	42	1.30/.59	36 (61)	24 (40)
SF0524513H	5.83 x 5.83 x 2.56 148 x 148 x 65	Type 12 / IP55	9011	24	NA	1	.17	3050	-4/-20	149/65	42	1.30/.59	36 (61)	24 (40)
SF0548514H	5.83 x 5.83 x 2.56 148 x 148 x 65	Type 12 / IP55	7035	48	NA	1	.08	3050	-4/-20	149/65	42	1.30/.59	36 (61)	24 (40)
SF0548513H	5.83 x 5.83 x 2.56 148 x 148 x 65	Type 12 / IP55	9011	48	NA	1	.08	3050	-4/-20	149/65	42	1.30/.59	36 (61)	24 (40)
SF0516514H	5.83 x 5.83 x 2.56 148 x 148 x 65	Type 12 / IP55	7035	115	50/60	1	.23	2650/3100	14/-10	131/55	42	1.30/.59	36 (61)	24 (40)
SF0516513H	5.83 x 5.83 x 2.56 148 x 148 x 65	Type 12 / IP55	9011	115	50/60	1	.23	2650/3100	14/-10	131/55	42	1.30/.59	36 (61)	24 (40)
SF0526514H	5.83 x 5.83 x 2.56 148 x 148 x 65	Type 12 / IP55	7035	230	50/60	1	.11	2650/3100	14/-10	131/55	42	1.30/.59	36 (61)	24 (40)
SF0526513H	5.83 x 5.83 x 2.56 148 x 148 x 65	Type 12 / IP55	9011	230	50/60	1	.11	2650/3100	14/-10	131/55	42	1.30/.59	36 (61)	24 (40)

Order Exhaust Grille Kit separately.

Filter Fan Packages

SF05 39 CFM (66 M³/Hr.) Side-Mount Filter Fan
Performance Curve

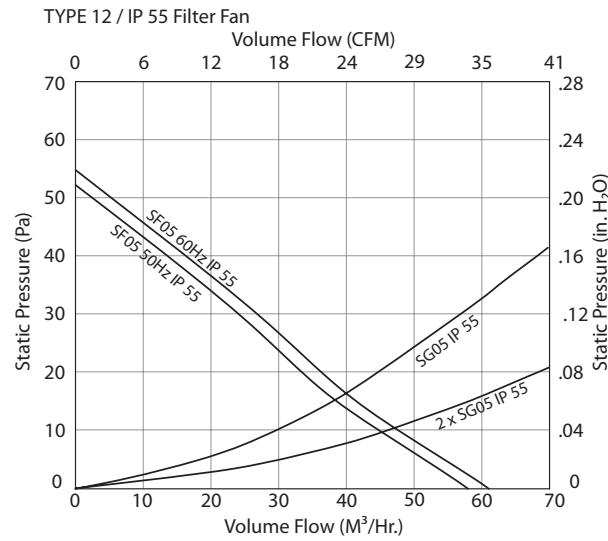
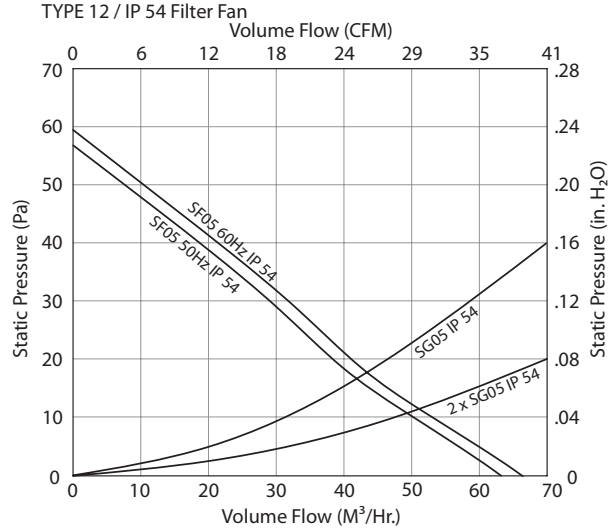

FILTER FAN

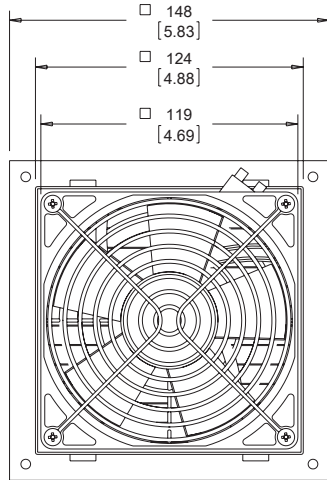

BACK VIEW

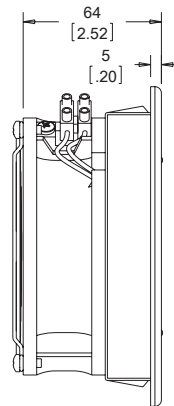

SIDE VIEW

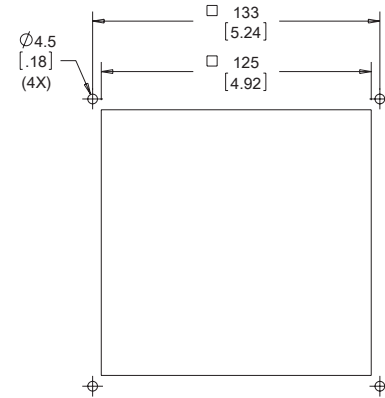

CUTOUT

EXHAUST GRILLE

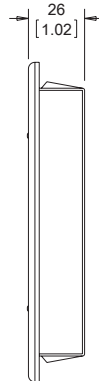
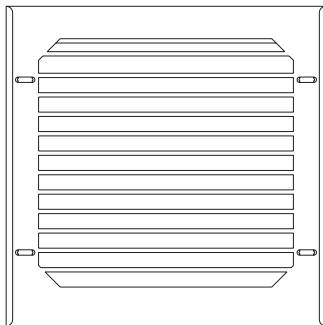

89051216

Order Exhaust Grille Kits separately

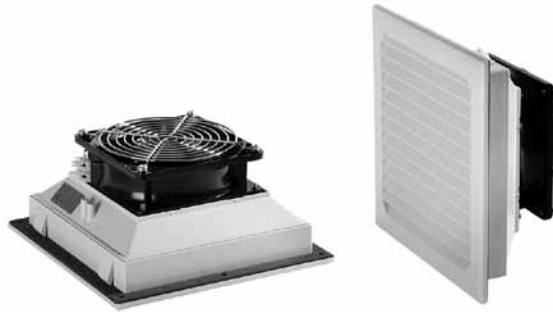
Filter Fan Packages
SF09 75 CFM (127 m³/hr.) Side-Mount Filter Fan

Features

- Free airflow up to 75 CFM (127 m³/hr.)
- Approximate size 9 in. (200 mm)
- Click-fit design quickly installs into enclosure wall; no tools or screws required
- Enclosure side wall mounting
- Standard foam-in-place gasket
- Similar cut-out sizes as other filter fan manufacturers
- Terminal wire connections
- Simple snap-open grille for easy filter replacement

Finish

- RAL 7035 light-gray UV-resistant plastic standard
- RAL 9011 black UV-resistant plastic optional

Industry Standards

UL/cUL recognized, CE, CSA (fan motor only)

Type 12, IP54 standard
Type 12, IP55 optional

Notes

Order Exhaust Grille Kits separately.

Bulletin: MCL

Performance Data SF09 75 CFM (127 m³/hr.) Side-Mount Filter Fan

Catalog Number	AxBxCin./mm	NEMA/ IP Rating	Color	Volt	Hz	Phase	Full Load Amps	Motor RPM	Low Temp. °F/°C	High Temp. °F/°C	Noise dB(A)	Ship Wt. (lb./kg)	Free Airflow CFM (m ³ /hr.)	Free Airflow with 1 Exhaust Grille (m ³ /hr.)
SF0924414H	8.03 x 8.03 x 3.54 204 x 204 x 90	Type 12 / IP54	7035	24	NA	1	.17	3050	-4/-20	149/65	51	1.74/.79	75 (127)	59 (100)
SF0924413H	8.03 x 8.03 x 3.54 204 x 204 x 90	Type 12 / IP54	9011	24	NA	1	.17	3050	-4/-20	149/65	51	1.74/.79	75 (127)	59 (100)
SF0948414H	8.03 x 8.03 x 3.54 204 x 204 x 90	Type 12 / IP54	7035	48	NA	1	.08	3050	-4/-20	149/65	51	1.74/.79	75 (127)	59 (100)
SF0948413H	8.03 x 8.03 x 3.54 204 x 204 x 90	Type 12 / IP54	9011	48	NA	1	.08	3050	-4/-20	149/65	51	1.74/.79	75 (127)	59 (100)
SF0916414H	8.03 x 8.03 x 3.54 204 x 204 x 90	Type 12 / IP54	7035	115	50/60	1	.23	2650/3100	14/-10	131/55	51	2.27/1.03	75 (127)	59 (100)
SF0916413H	8.03 x 8.03 x 3.54 204 x 204 x 90	Type 12 / IP54	9011	115	50/60	1	.23	2650/3100	14/-10	131/55	51	2.27/1.03	75 (127)	59 (100)
SF0926414H	8.03 x 8.03 x 3.54 204 x 204 x 90	Type 12 / IP54	7035	230	50/60	1	.11	2650/3100	14/-10	131/55	51	2.27/1.03	75 (127)	59 (100)
SF0926413H	8.03 x 8.03 x 3.54 204 x 204 x 90	Type 12 / IP54	9011	230	50/60	1	.11	2650/3100	14/-10	131/55	51	2.27/1.03	75 (127)	59 (100)
SF0924514H	8.03 x 8.03 x 3.54 204 x 204 x 90	Type 12 / IP55	7035	24	NA	1	.17	3050	-4/-20	149/65	51	1.74/.79	70 (118)	54 (92)
SF0924513H	8.03 x 8.03 x 3.54 204 x 204 x 90	Type 12 / IP55	9011	24	NA	1	.17	3050	-4/-20	149/65	51	1.74/.79	70 (118)	54 (92)
SF0948514H	8.03 x 8.03 x 3.54 204 x 204 x 90	Type 12 / IP55	7035	48	NA	1	.08	3050	-4/-20	149/65	51	1.74/.79	70 (118)	54 (92)
SF0948513H	8.03 x 8.03 x 3.54 204 x 204 x 90	Type 12 / IP55	9011	48	NA	1	.08	3050	-4/-20	149/65	51	1.74/.79	70 (118)	54 (92)
SF0916514H	8.03 x 8.03 x 3.54 204 x 204 x 90	Type 12 / IP55	7035	115	50/60	1	.23	2650/3100	14/-10	131/55	51	2.27/1.03	70 (118)	54 (92)
SF0916513H	8.03 x 8.03 x 3.54 204 x 204 x 90	Type 12 / IP55	9011	115	50/60	1	.23	2650/3100	14/-10	131/55	51	2.27/1.03	70 (118)	54 (92)
SF0926514H	8.03 x 8.03 x 3.54 204 x 204 x 90	Type 12 / IP55	7035	230	50/60	1	.11	2650/3100	14/-10	131/55	51	2.27/1.03	70 (118)	54 (92)
SF0926513H	8.03 x 8.03 x 3.54 204 x 204 x 90	Type 12 / IP55	9011	230	50/60	1	.11	2650/3100	14/-10	131/55	51	2.27/1.03	70 (118)	54 (92)

Order Exhaust Grille Kit separately.

Filter Fan Packages

SF09 75 CFM (127 M³/Hr.) Side-Mount Filter Fan Performance Curve

TYPE 12 / IP 54 Filter Fan

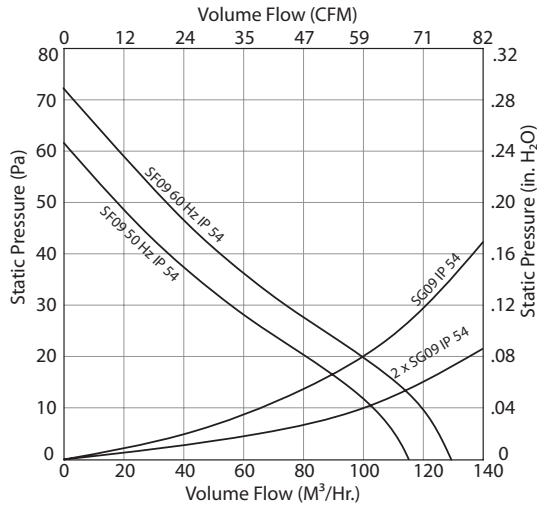

TYPE 12 / IP 55 Filter Fan

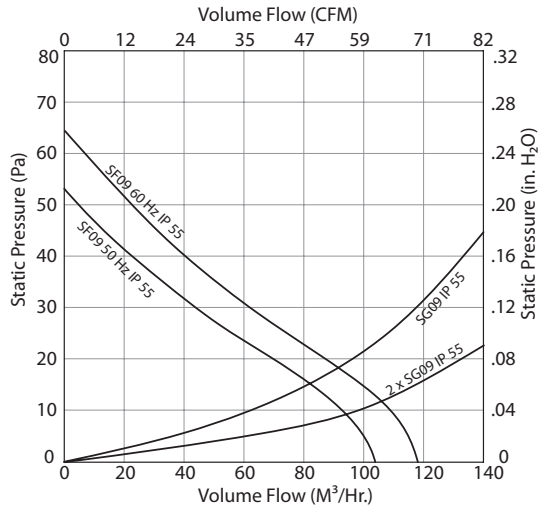

Filter Fan Packages

FILTER FAN

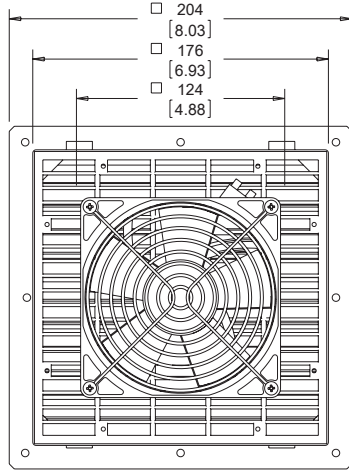

BACK VIEW

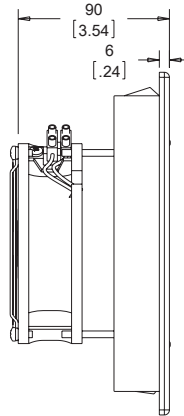

SIDE VIEW

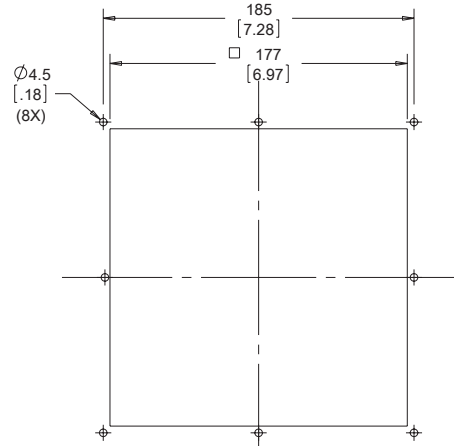

CUTOUT

EXHAUST GRILLE

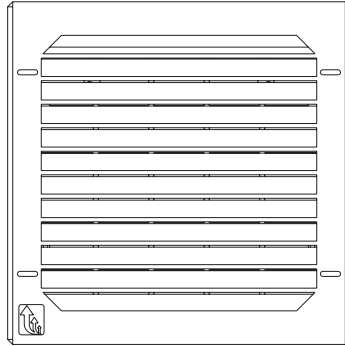

Order Exhaust Grille Kits separately

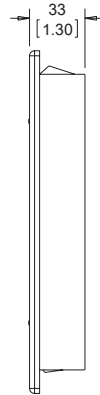

89051217

Filter Fan Packages

ST10 100 CFM (170 m³/hr.) Thin Side-Mount Filter Fan

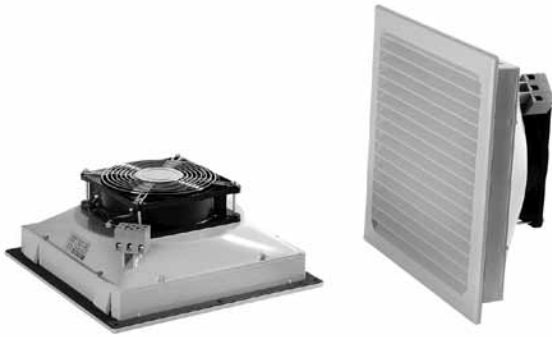

Features

- Free airflow up to 100 CFM (170 m³/hr.)
- Approximate size 10 in. (250 mm)
- Click-fit design quickly installs into enclosure wall; no tools or screws required
- Thin depth to minimize cabinet intrusion
- Enclosure side wall mounting
- Standard foam-in-place gasket
- Similar cut-out sizes as other filter fan manufacturers
- Terminal wire connections
- Simple snap-open grille for easy filter replacement

Finish

- RAL 7035 light-gray UV-resistant plastic standard
- RAL 9011 black UV-resistant plastic optional

Industry Standards

UL/cUL recognized, CE, CSA (fan motor only)

Type 12, IP54 standard
Type 12, IP55 optional

Notes

Order Exhaust Grille Kits separately.

Bulletin: MCL

Performance Data ST10 100 CFM (170 m³/hr.) Thin Side-Mount Filter Fan

Catalog Number	AxBxC in./mm	NEMA/ IP Rating	Color	Volt	Hz	Phase	Full Load Amps	Motor RPM	Low Temp. °F/°C	High Temp. °F/°C	Noise dB(A)	Ship Wt. (lb./kg)	Free Airflow CFM (m ³ /hr.)	Free Airflow with 1 Exhaust Grille (m ³ /hr.)
ST1024414H	9.84 x 9.84 x 4.02 250 x 250 x 102	Type 12 / IP54	7035	24	NA	1	.27	3150	-4/-20	149/65	46	2.54/1.15	100 (170)	74 (125)
ST1024413H	9.84 x 9.84 x 4.02 250 x 250 x 102	Type 12 / IP54	9011	24	NA	1	.27	3150	-4/-20	149/65	46	2.54/1.15	100 (170)	74 (125)
ST1048414H	9.84 x 9.84 x 4.02 250 x 250 x 102	Type 12 / IP54	9011	48	NA	1	.14	3150	-4/-20	149/65	46	2.54/1.15	100 (170)	74 (125)
ST1048413H	9.84 x 9.84 x 4.02 250 x 250 x 102	Type 12 / IP54	9011	48	NA	1	.14	3150	-4/-20	149/65	46	2.54/1.15	100 (170)	74 (125)
ST1016414H	9.84 x 9.84 x 4.02 250 x 250 x 102	Type 12 / IP54	7035	115	50/60	1	.20	2750/3100	14/-10	131/55	44	3.09/1.40	100 (170)	74 (125)
ST1016413H	9.84 x 9.84 x 4.02 250 x 250 x 102	Type 12 / IP54	9011	115	50/60	1	.20	2750/3100	14/-10	131/55	44	3.09/1.40	100 (170)	74 (125)
ST1026414H	9.84 x 9.84 x 4.02 250 x 250 x 102	Type 12 / IP54	7035	230	50/60	1	.10	2750/3100	14/-10	131/55	44	3.09/1.40	100 (170)	74 (125)
ST1026413H	9.84 x 9.84 x 4.02 250 x 250 x 102	Type 12 / IP54	9011	230	50/60	1	.10	2750/3100	14/-10	131/55	44	3.09/1.40	100 (170)	74 (125)
ST1024514H	9.84 x 9.84 x 4.02 250 x 250 x 102	Type 12 / IP55	7035	24	NA	1	.27	3150	-4/-20	149/65	46	2.54/1.15	92 (156)	67 (114)
ST1024513H	9.84 x 9.84 x 4.02 250 x 250 x 102	Type 12 / IP55	9011	24	NA	1	.27	3150	-4/-20	149/65	46	2.54/1.15	92 (156)	67 (114)
ST1048514H	9.84 x 9.84 x 4.02 250 x 250 x 102	Type 12 / IP55	7035	48	NA	1	.14	3150	-4/-20	149/65	46	2.54/1.15	92 (156)	67 (114)
ST1048513H	9.84 x 9.84 x 4.02 250 x 250 x 102	Type 12 / IP55	9011	48	NA	1	.14	3150	-4/-20	149/65	46	2.54/1.15	92 (156)	67 (114)
ST1016514H	9.84 x 9.84 x 4.02 250 x 250 x 102	Type 12 / IP55	7035	115	50/60	1	.20	2750/3100	14/-10	131/55	44	3.09/1.40	92 (156)	67 (114)
ST1016513H	9.84 x 9.84 x 4.02 250 x 250 x 102	Type 12 / IP55	9011	115	50/60	1	.20	2750/3100	14/-10	131/55	44	3.09/1.40	92 (156)	67 (114)
ST1026514H	9.84 x 9.84 x 4.02 250 x 250 x 102	Type 12 / IP55	7035	230	50/60	1	.10	2750/3100	14/-10	131/55	44	3.09/1.40	92 (156)	67 (114)
ST1026513H	9.84 x 9.84 x 4.02 250 x 250 x 102	Type 12 / IP55	9011	230	50/60	1	.10	2750/3100	14/-10	131/55	44	3.09/1.40	92 (156)	67 (114)

Order Exhaust Grille Kit separately.

Filter Fan Packages

ST10 100 CFM (170 M³/Hr.) Thin Side-Mount Filter Fan Performance Curve

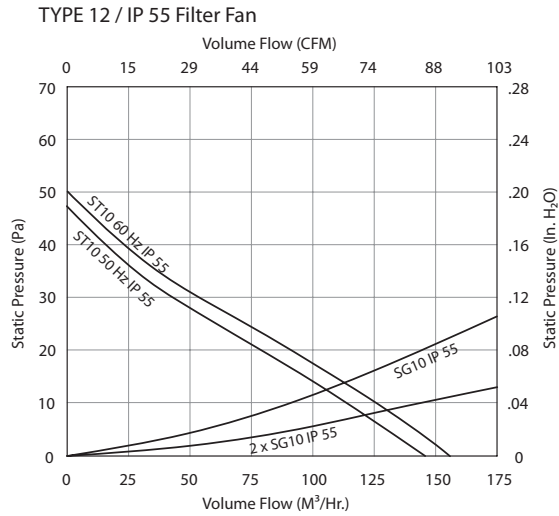
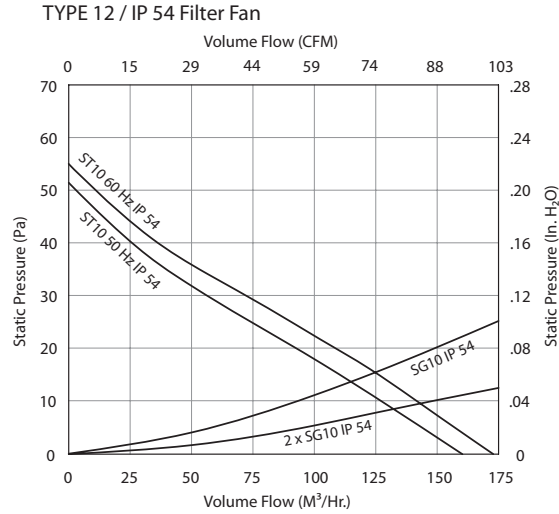

FILTER FAN

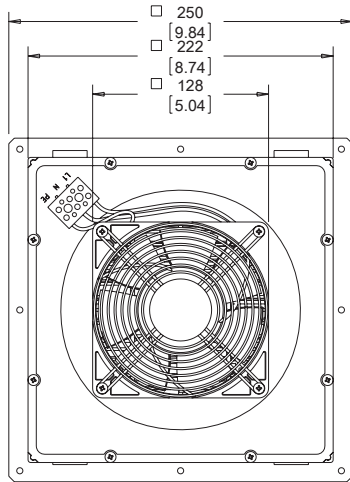

BACK VIEW

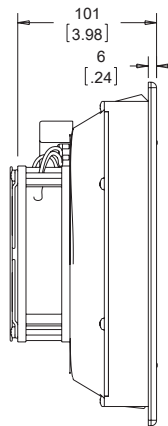

SIDE VIEW

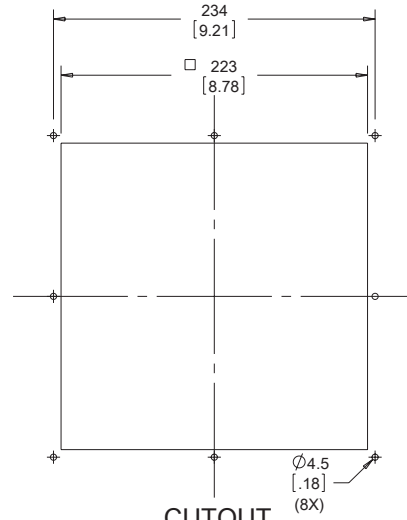

CUTOUT

EXHAUST GRILLE

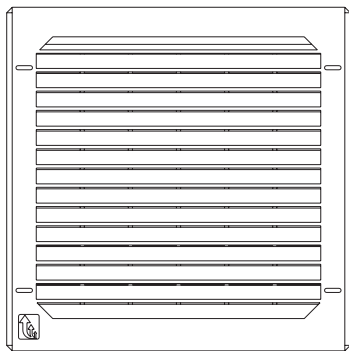

Order Exhaust Grille Kits separately

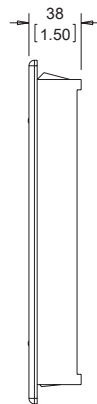

89051218

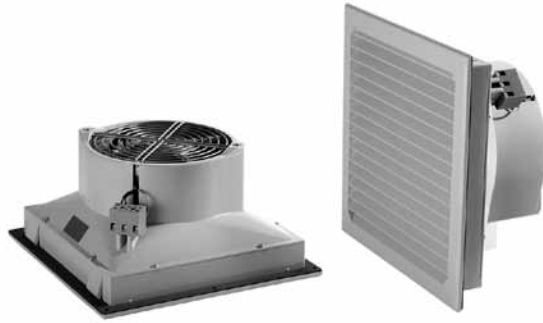
Filter Fan Packages
SF10 162 CFM (275 m³/hr.) Side-Mount Filter Fan

Features

- Free airflow up to 162 CFM (275 m³/hr.)
- Approximate size 10 in. (250 mm)
- Click-fit design quickly installs into enclosure wall; no tools or screws required
- Enclosure side wall mounting
- Standard foam-in-place gasket
- Similar cut-out sizes as other filter fan manufacturers
- Terminal wire connections
- Simple snap-open grille for easy filter replacement

Finish

- RAL 7035 light-gray UV-resistant plastic standard
- RAL 9011 black UV-resistant plastic optional

Industry Standards

UL/cUL recognized, CE, CSA (fan motor only)

Type 12, IP54 standard
Type 12, IP55 optional

Notes

Order Exhaust Grille Kits separately.

Bulletin: MCL

Performance Data SF10 162 CFM (275 m³/hr.) Side-Mount Filter Fan

Catalog Number	AxBxC in./mm	NEMA/ IP Rating	Color	Volt	Hz	Phase	Full Load Amps	Motor RPM	Low Temp. °F/°C	High Temp. °F/°C	Noise dB(A)	Ship Wt. (lb./kg)	Free Airflow CFM (m ³ /hr.)	Free Airflow with 1 Exhaust Grille (m ³ /hr.)
SF1024414H	9.84 x 9.84 x 4.72 250 x 250 x 120	Type 12 / IP54	7035	24	NA	1	.33	2950	14/-10	131/55	52	4.19/1.9	162 (275)	133 (226)
SF1024413H	9.84 x 9.84 x 4.72 250 x 250 x 120	Type 12 / IP54	9011	24	NA	1	.33	2950	14/-10	131/55	52	4.19/1.9	162 (275)	133 (226)
SF1048414H	9.84 x 9.84 x 4.72 250 x 250 x 120	Type 12 / IP54	7035	48	NA	1	.66	2950	14/-10	131/55	52	4.19/1.9	162 (275)	133 (226)
SF1048413H	9.84 x 9.84 x 4.72 250 x 250 x 120	Type 12 / IP54	9011	48	NA	1	.66	2950	14/-10	131/55	52	4.19/1.9	162 (275)	133 (226)
SF1016414H	9.84 x 9.84 x 4.72 250 x 250 x 120	Type 12 / IP54	7035	115	50/60	1	.53/50	2760/3030	14/-10	131/55	52	4.19/1.9	162 (275)	133 (226)
SF1016413H	9.84 x 9.84 x 4.72 250 x 250 x 120	Type 12 / IP54	9011	115	50/60	1	.53/50	2760/3030	14/-10	131/55	52	4.19/1.9	162 (275)	133 (226)
SF1026414H	9.84 x 9.84 x 4.72 250 x 250 x 120	Type 12 / IP54	7035	230	50/60	1	.30/25	2760/3030	14/-10	131/55	52	4.19/1.9	162 (275)	133 (226)
SF1026413H	9.84 x 9.84 x 4.72 250 x 250 x 120	Type 12 / IP54	9011	230	50/60	1	.30/25	2760/3030	14/-10	131/55	52	4.19/1.9	162 (275)	133 (226)
SF1024514H	9.84 x 9.84 x 4.72 250 x 250 x 120	Type 12 / IP55	7035	24	NA	1	.33	2950	14/-10	131/55	52	4.19/1.9	149 (253)	122 (207)
SF1024513H	9.84 x 9.84 x 4.72 250 x 250 x 120	Type 12 / IP55	9011	24	NA	1	.33	2950	14/-10	131/55	52	4.19/1.9	149 (253)	122 (207)
SF1048514H	9.84 x 9.84 x 4.72 250 x 250 x 120	Type 12 / IP55	7035	48	NA	1	.66	2950	14/-10	131/55	52	4.19/1.9	149 (253)	122 (207)
SF1048513H	9.84 x 9.84 x 4.72 250 x 250 x 120	Type 12 / IP55	9011	48	NA	1	.66	2950	14/-10	131/55	52	4.19/1.9	149 (253)	122 (207)
SF1016514H	9.84 x 9.84 x 4.72 250 x 250 x 120	Type 12 / IP55	7035	115	50/60	1	.53/50	2760/3030	14/-10	131/55	52	4.19/1.9	149 (253)	122 (207)
SF1016513H	9.84 x 9.84 x 4.72 250 x 250 x 120	Type 12 / IP55	9011	115	50/60	1	.53/50	2760/3030	14/-10	131/55	52	4.19/1.9	149 (253)	122 (207)
SF1026514H	9.84 x 9.84 x 4.72 250 x 250 x 120	Type 12 / IP55	7035	230	50/60	1	.30/25	2760/3030	14/-10	131/55	52	4.19/1.9	149 (253)	122 (207)
SF1026513H	9.84 x 9.84 x 4.72 250 x 250 x 120	Type 12 / IP55	9011	230	50/60	1	.30/25	2760/3030	14/-10	131/55	52	4.19/1.9	149 (253)	122 (207)

Order Exhaust Grille Kit separately.

Filter Fan Packages

SF10 162 CFM (275 M³/Hr.) Side-Mount Filter Fan Performance Curve

TYPE 12 / IP 54 Filter Fan

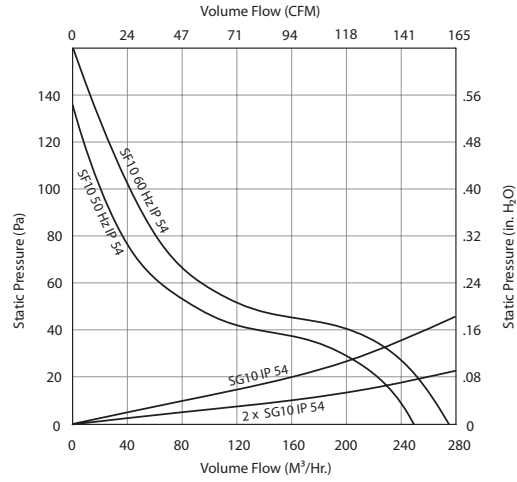

TYPE 12 / IP 55 Filter Fan

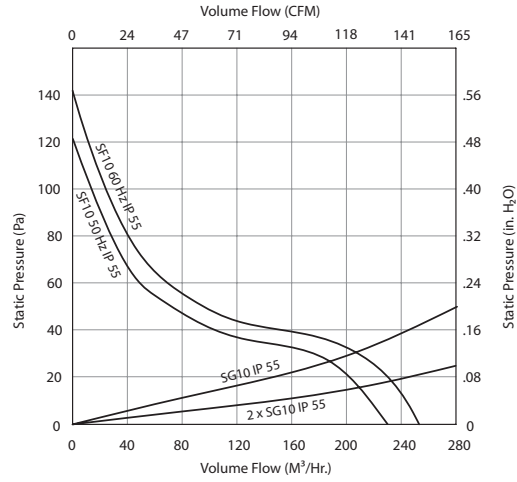

Filter Fan Packages

FILTER FAN

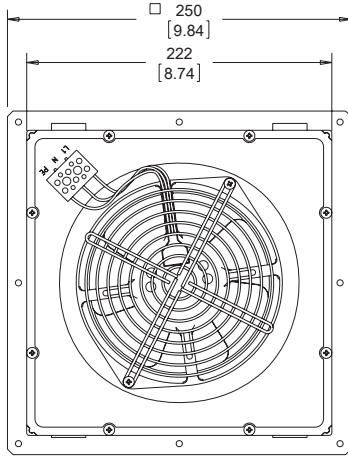

BACK VIEW

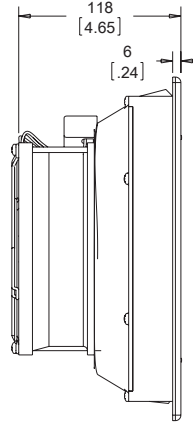

SIDE VIEW

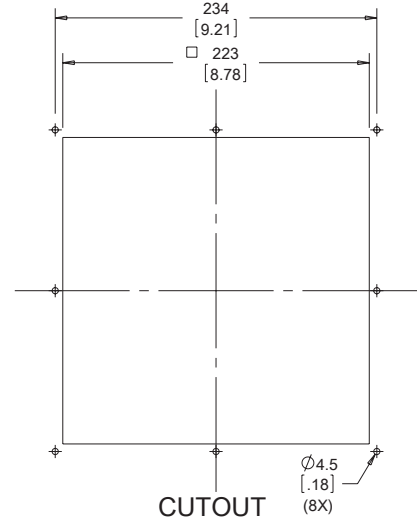

CUTOUT

EXHAUST GRILLE

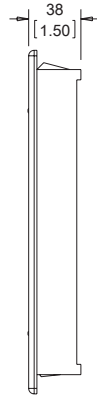
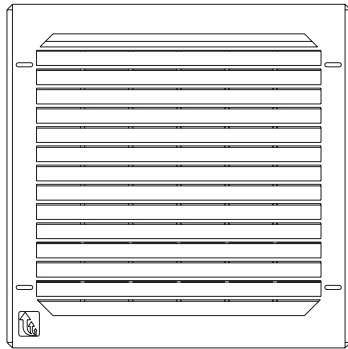

Order Exhaust Grille Kit separately

89051219

Filter Fan Packages

ST13 303 CFM (515 m³/hr.) Thin Side-Mount Filter Fan

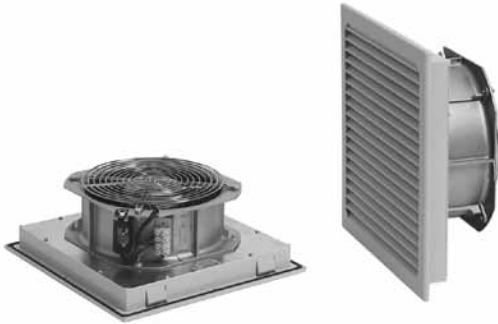

Features

- Free airflow up to 303 CFM (515 m³/hr.)
- Approximate size 13 in. (325 mm)
- Click-fit design quickly installs into enclosure wall; no tools or screws required
- Thin depth to minimize cabinet intrusion
- Enclosure side wall mounting
- Reverse airflow option to increase static pressure
- Standard foam-in-place gasket
- Similar cut-out sizes as other filter fan manufacturers
- Terminal wire connections
- Simple snap-open grille for easy filter replacement

Finish

- RAL 7035 light-gray UV-resistant plastic standard
- RAL 9011 black UV-resistant plastic optional

Industry Standards

UL/cUL recognized, CE, CSA (fan motor only)

Type 12, IP54 standard
Type 12, IP55 optional

Notes

Order Exhaust Grille Kits separately.

Bulletin: MCL

Performance Data ST13 303 CFM (515 m³/hr.) Thin Side-Mount Filter Fan

Catalog Number	AxBxC in./mm	NEMA/ IP Rating	Color	Volt	Hz	Phase	Full Load Amps	Motor RPM	Low Temp. °F/°C	High Temp. °F/°C	Noise dB(A)	Ship Wt. (lb./kg)	Free Airflow CFM (m ³ /hr.)	Free Airflow with 1 Exhaust Grille (m ³ /hr.)
ST1316414H	12.72 x 12.72 x 4.80 323 x 323 x 122	Type 12 / IP54	7035	115	50/60	1	.58/.70	2550/2800	14/-10	131/55	60	7.5/3.4	303 (515)	209 (355)
ST1316413H	12.72 x 12.72 x 4.80 323 x 323 x 122	Type 12 / IP54	9011	115	50/60	1	.58/.70	2550/2800	14/-10	131/55	60	7.5/3.4	303 (515)	209 (355)
ST1316414RH	12.72 x 12.72 x 4.80 323 x 323 x 122	Type 12 / IP54	7035	115	50/60	1	.58/.70	2550/2800	14/-10	131/55	60	7.5/3.4	303 (515)	209 (355)
ST1316413RH	12.72 x 12.72 x 4.80 323 x 323 x 122	Type 12 / IP54	9011	115	50/60	1	.58/.70	2550/2800	14/-10	131/55	60	7.5/3.4	303 (515)	209 (355)
ST1326414H	12.72 x 12.72 x 4.80 323 x 323 x 122	Type 12 / IP54	7035	230	50/60	1	.29/.35	2550/2800	14/-10	131/55	60	7.5/3.4	303 (515)	209 (355)
ST1326413H	12.72 x 12.72 x 4.80 323 x 323 x 122	Type 12 / IP54	9011	230	50/60	1	.29/.35	2550/2800	14/-10	131/55	60	7.5/3.4	303 (515)	209 (355)
ST1326414RH	12.72 x 12.72 x 4.80 323 x 323 x 122	Type 12 / IP54	7035	230	50/60	1	.29/.35	2550/2800	14/-10	131/55	60	7.5/3.4	303 (515)	209 (355)
ST1326413RH	12.72 x 12.72 x 4.80 323 x 323 x 122	Type 12 / IP54	9011	230	50/60	1	.29/.35	2550/2800	14/-10	131/55	60	7.5/3.4	303 (515)	209 (355)
ST1316514H	12.72 x 12.72 x 4.80 323 x 323 x 122	Type 12 / IP55	7035	115	50/60	1	.58/.70	2550/2800	14/-10	131/55	60	7.5/3.4	277 (470)	191 (325)
ST1316513H	12.72 x 12.72 x 4.80 323 x 323 x 122	Type 12 / IP55	9011	115	50/60	1	.58/.70	2550/2800	14/-10	131/55	60	7.5/3.4	277 (470)	191 (325)
ST1316514RH	12.72 x 12.72 x 4.80 323 x 323 x 122	Type 12 / IP55	7035	115	50/60	1	.58/.70	2550/2800	14/-10	131/55	60	7.5/3.4	277 (470)	191 (325)
ST1316513RH	12.72 x 12.72 x 4.80 323 x 323 x 122	Type 12 / IP55	9011	115	50/60	1	.58/.70	2550/2800	14/-10	131/55	60	7.5/3.4	277 (470)	191 (325)
ST1326514H	12.72 x 12.72 x 4.80 323 x 323 x 122	Type 12 / IP55	7035	230	50/60	1	.29/.35	2550/2800	14/-10	131/55	60	7.5/3.4	277 (470)	191 (325)
ST1326513H	12.72 x 12.72 x 4.80 323 x 323 x 122	Type 12 / IP55	9011	230	50/60	1	.29/.35	2550/2800	14/-10	131/55	60	7.5/3.4	277 (470)	191 (325)
ST1326514RH	12.72 x 12.72 x 4.80 323 x 323 x 122	Type 12 / IP55	7035	230	50/60	1	.29/.35	2550/2800	14/-10	131/55	60	7.5/3.4	277 (470)	191 (325)
ST1326513RH	12.72 x 12.72 x 4.80 323 x 323 x 122	Type 12 / IP55	9011	230	50/60	1	.29/.35	2550/2800	14/-10	131/55	60	7.5/3.4	277 (470)	191 (325)

Order Exhaust Grille Kit separately.

Filter Fan Packages

ST13 303 CFM (515 M³/Hr.) Thin Side-Mount Filter Fan Performance Curve

TYPE 12 / IP 54 Filter Fan

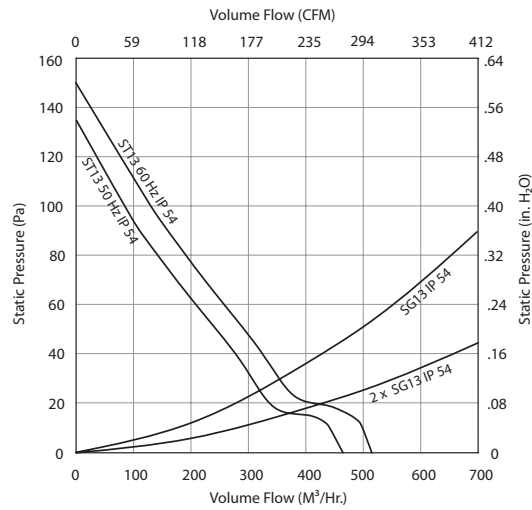

TYPE 12 / IP 55 Filter Fan

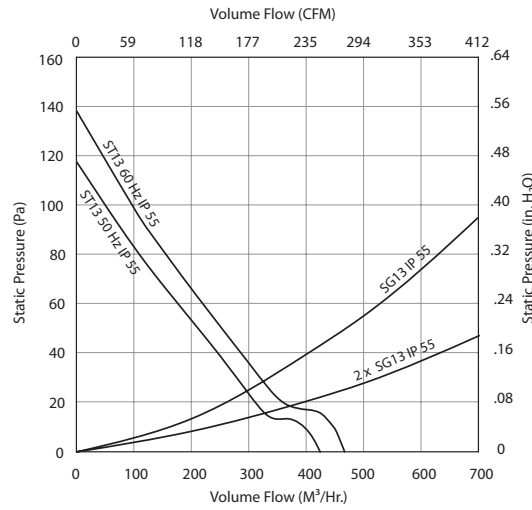

FILTER FAN

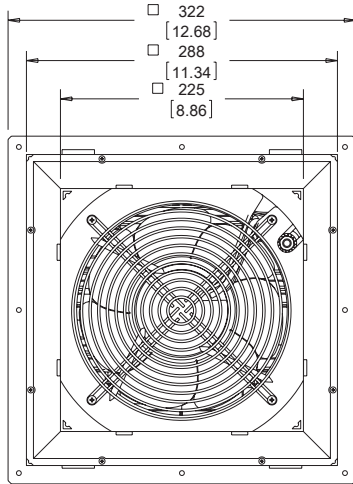

BACK VIEW

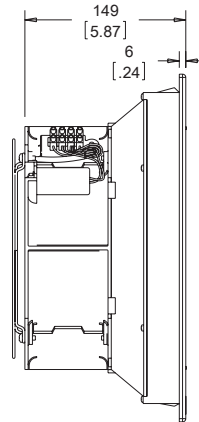

SIDE VIEW

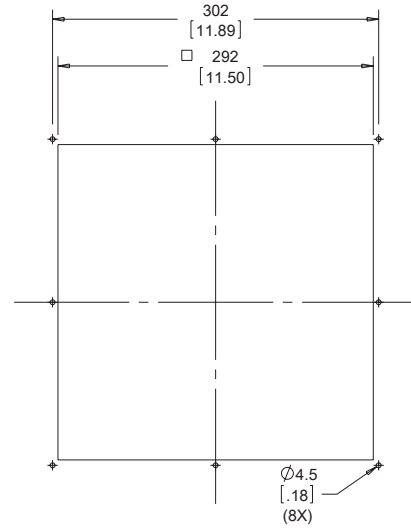

CUTOUT

EXHAUST GRILLE

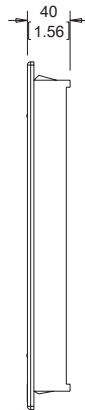
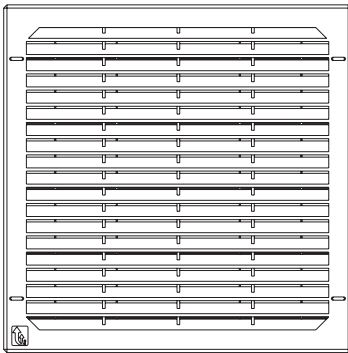

89051221

Order Exhaust Grille Kit separately

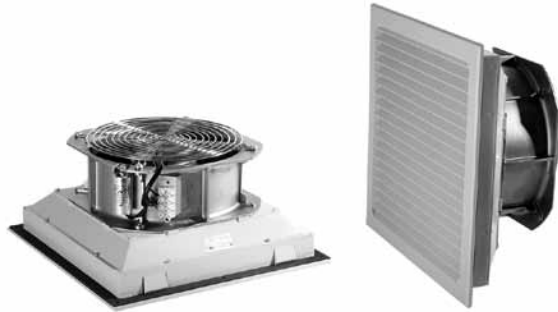
Filter Fan Packages
SF13 376 CFM (638 m³/hr.) Side-Mount Filter Fan

Features

- Free airflow up to 376 CFM (638 m³/hr.)
- Approximate size 13 in. (325 mm)
- Click-fit design quickly installs into enclosure wall; no tools or screws required
- Enclosure side wall mounting
- Reverse airflow option to increase static pressure
- Standard foam-in-place gasket
- Similar cut-out sizes as other filter fan manufacturers
- Terminal wire connections
- Simple snap-open grille for easy filter replacement

Finish

- RAL 7035 light-gray UV-resistant plastic standard
- RAL 9011 black UV-resistant plastic optional

Industry Standards

UL/cUL recognized, CE, CSA (fan motor only)

Type 12, IP54 standard
Type 12, IP55 optional

Notes

Order Exhaust Grille Kits separately.

Bulletin: MCL

Performance Data SF13 376 CFM (638 m³/hr.) Side-Mount Filter Fan

Catalog Number	AxBxC in./mm	NEMA/ IP Rating	Color	Volt	Hz	Phase	Full Load Amps	Motor RPM	Low Temp. °F/°C	High Temp. °F/°C	Noise dB(A)	Ship Wt. (lb./kg)	Free Airflow CFM (m ³ /hr.)	Free Airflow with 1 Exhaust Grille (m ³ /hr.)
SF1324414H	12.72 x 12.72 x 5.83 323 x 323 x 148	Type 12 / IP54	7035	24	NA	1	2.60	2950	-13/-25	140/60	60	7.50/3.4	375 (638)	249 (423)
SF1324413H	12.72 x 12.72 x 5.83 323 x 323 x 148	Type 12 / IP54	9011	24	NA	1	2.60	2950	-13/-25	140/60	60	7.50/3.4	375 (638)	249 (423)
SF1348414H	12.72 x 12.72 x 5.83 323 x 323 x 148	Type 12 / IP54	7035	48	NA	1	1.30	2950	-13/-25	140/60	60	7.50/3.4	375 (638)	249 (423)
SF1348413H	12.72 x 12.72 x 5.83 323 x 323 x 148	Type 12 / IP54	9011	48	NA	1	1.30	2950	-13/-25	140/60	60	7.50/3.4	375 (638)	249 (423)
SF1316414H	12.72 x 12.72 x 5.83 323 x 323 x 148	Type 12 / IP54	7035	115	50/60	1	.58/.70	2550/2800	14/-10	131/55	60	7.50/3.4	375 (638)	249 (423)
SF1316413H	12.72 x 12.72 x 5.83 323 x 323 x 148	Type 12 / IP54	9011	115	50/60	1	.58/.70	2550/2800	14/-10	131/55	60	7.50/3.4	375 (638)	249 (423)
SF1316414RH	12.72 x 12.72 x 5.83 323 x 323 x 148	Type 12 / IP54	7035	115	50/60	1	.58/.70	2550/2800	14/-10	131/55	60	7.50/3.4	375 (638)	249 (423)
SF1316413RH	12.72 x 12.72 x 5.83 323 x 323 x 148	Type 12 / IP54	9011	115	50/60	1	.58/.70	2550/2800	14/-10	131/55	60	7.50/3.4	375 (638)	249 (423)
SF1326414H	12.72 x 12.72 x 5.83 323 x 323 x 148	Type 12 / IP54	7035	230	50/60	1	.29/.35	2550/2800	14/-10	131/55	60	7.50/3.4	375 (638)	249 (423)
SF1326413H	12.72 x 12.72 x 5.83 323 x 323 x 148	Type 12 / IP54	9011	230	50/60	1	.29/.35	2550/2800	14/-10	131/55	60	7.50/3.4	375 (638)	249 (423)
SF1326414RH	12.72 x 12.72 x 5.83 323 x 323 x 148	Type 12 / IP54	7035	230	50/60	1	.29/.35	2550/2800	14/-10	131/55	60	7.50/3.4	375 (638)	249 (423)
SF1326413RH	12.72 x 12.72 x 5.83 323 x 323 x 148	Type 12 / IP54	9011	230	50/60	1	.29/.35	2550/2800	14/-10	131/55	60	7.50/3.4	375 (638)	249 (423)
SF1324514H	12.72 x 12.72 x 5.83 323 x 323 x 148	Type 12 / IP55	7035	24	NA	1	2.60	2950	-13/-25	140/60	60	7.50/3.4	346 (587)	228 (387)
SF1324513H	12.72 x 12.72 x 5.83 323 x 323 x 148	Type 12 / IP55	9011	24	NA	1	2.60	2950	-13/-25	140/60	60	7.50/3.4	346 (587)	228 (387)
SF1348514H	12.72 x 12.72 x 5.83 323 x 323 x 148	Type 12 / IP55	7035	48	NA	1	1.30	2950	-13/-25	140/60	60	7.50/3.4	346 (587)	228 (387)
SF1348513H	12.72 x 12.72 x 5.83 323 x 323 x 148	Type 12 / IP55	9011	48	NA	1	1.30	2950	-13/-25	140/60	60	7.50/3.4	346 (587)	228 (387)
SF1316514H	12.72 x 12.72 x 5.83 323 x 323 x 148	Type 12 / IP55	7035	115	50/60	1	.58/.70	2550/2800	14/-10	131/55	60	7.50/3.4	346 (587)	228 (387)
SF1316513H	12.72 x 12.72 x 5.83 323 x 323 x 148	Type 12 / IP55	9011	115	50/60	1	.58/.70	2550/2800	14/-10	131/55	60	7.50/3.4	346 (587)	228 (387)
SF1326514H	12.72 x 12.72 x 5.83 323 x 323 x 148	Type 12 / IP55	7035	230	50/60	1	.29/.35	2550/2800	14/-10	131/55	60	7.50/3.4	346 (587)	228 (387)
SF1326513H	12.72 x 12.72 x 5.83 323 x 323 x 148	Type 12 / IP55	9011	230	50/60	1	.29/.35	2550/2800	14/-10	131/55	60	7.50/3.4	346 (587)	228 (387)

Order Exhaust Grille Kit separately.

Filter Fan Packages

SF13 376 CFM (638 M³/Hr.) Side-Mount Filter Fan Performance Curve

TYPE 12 / IP 54 Filter Fan

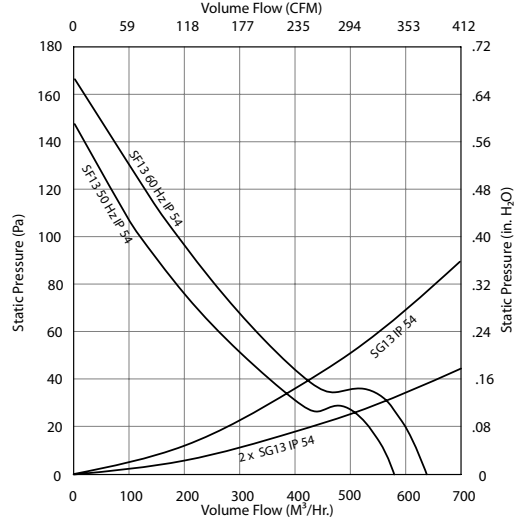

TYPE 12 / IP 55 Filter Fan

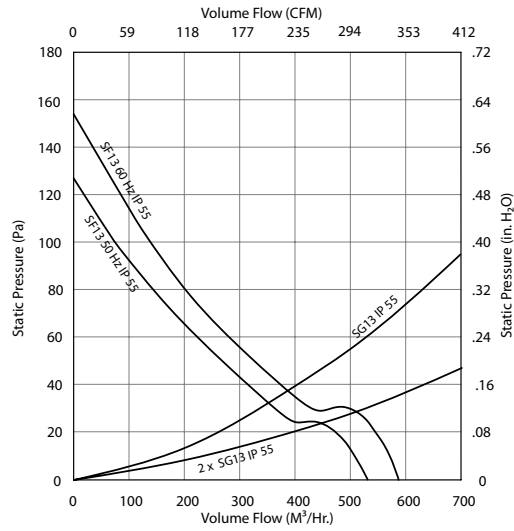

FILTER FAN

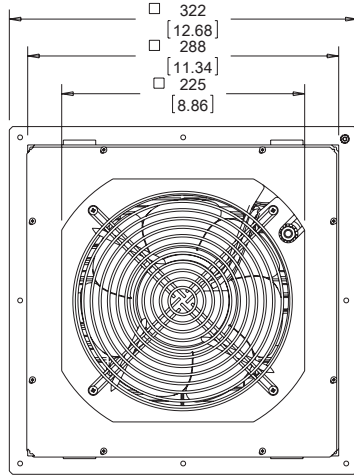

BACK VIEW

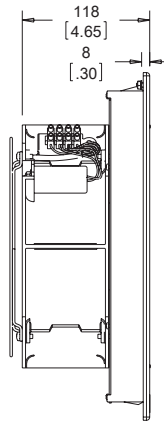

SIDE VIEW

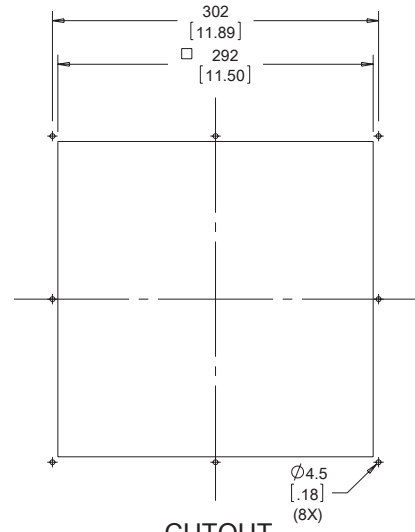

CUTOUT

EXHAUST GRILLE

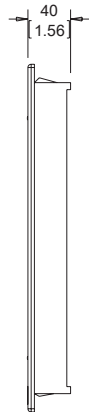
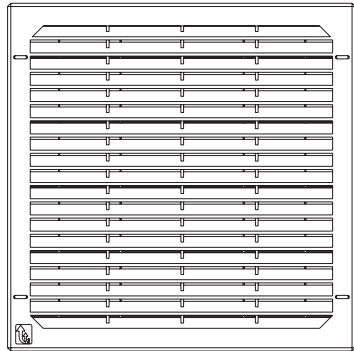

89051222

Order Exhaust Grille Kit separately

Filter Fan Packages

SF13 473 CFM (803 m³/hr.) Side-Mount Filter Fan



Features

- Free airflow up to 473 CFM (803 m³/hr.)
- Approximate size 13 in. (325 mm)
- Click-fit design quickly installs into enclosure wall; no tools or screws required
- Enclosure side wall mounting
- Reverse airflow option to increase static pressure
- Standard foam-in-place gasket
- Similar cut-out sizes as other filter fan manufacturers
- Terminal wire connections
- Simple snap-open grille for easy filter replacement

Finish

- RAL 7035 light-gray UV-resistant plastic standard
- RAL 9011 black UV-resistant plastic optional

Industry Standards

UL/cUL recognized, CE, CSA (fan motor only)

Type 12, IP54 standard
Type 12, IP55 optional

Notes

Order Exhaust Grille Kits separately.

Bulletin: MCL

Performance Data SF13 473 CFM (803 m³/hr.) Side-Mount Filter Fan

Catalog Number	AxBxC in./mm	NEMA/ IP Rating	Color	Voltage	Hz	Phase	Full Load Amps	Motor RPM	Low Temp. °F/°C	High Temp. °F/°C	Noise dB(A)	Ship Wt. (lb./kg)	Free Airflow CFM (m ³ /hr.)	Free Airflow with 1 Exhaust Grille (m ³ /hr.)
SF1316424H	12.72 x 12.72 x 6.38 323 x 323 x 162	Type 12 / IP54	7035	115	50/60	1	1.02/1.4	2450/2650	14/-10	131/55	70	7.72/3.5	473 (803)	343 (583)
SF1316423H	12.72 x 12.72 x 6.38 323 x 323 x 162	Type 12 / IP54	9011	115	50/60	1	1.02/1.4	2450/2650	14/-10	131/55	70	7.72/3.5	473 (803)	343 (583)
SF1316424RH	12.72 x 12.72 x 6.38 323 x 323 x 162	Type 12 / IP54	7035	115	50/60	1	1.05/1.47	2450/2650	14/-10	131/55	70	7.72/3.5	473 (803)	343 (583)
SF1316423RH	12.72 x 12.72 x 6.38 323 x 323 x 162	Type 12 / IP54	9011	115	50/60	1	1.05/1.47	2450/2650	14/-10	131/55	70	7.72/3.5	473 (803)	343 (583)
SF1326424H	12.72 x 12.72 x 6.38 323 x 323 x 162	Type 12 / IP54	7035	230	50/60	1	.51/.74	2550/2750	14/-10	131/55	70	7.72/3.5	473 (803)	343 (583)
SF1326423H	12.72 x 12.72 x 6.38 323 x 323 x 162	Type 12 / IP54	9011	230	50/60	1	.51/.74	2550/2750	14/-10	131/55	70	7.72/3.5	473 (803)	343 (583)
SF1326424RH	12.72 x 12.72 x 6.38 323 x 323 x 162	Type 12 / IP54	7035	230	50/60	1	.51/.70	2550/2750	14/-10	131/55	70	7.72/3.5	473 (803)	343 (583)
SF1326423RH	12.72 x 12.72 x 6.38 323 x 323 x 162	Type 12 / IP54	9011	230	50/60	1	.51/.70	2550/2750	14/-10	131/55	70	7.72/3.5	473 (803)	343 (583)
SF1340424H	12.72 x 12.72 x 6.38 323 x 323 x 162	Type 12 / IP54	7035	400	50/60	3	.22/.26	2650/2900	14/-10	131/55	70	7.72/3.5	473 (803)	343 (583)
SF1340423H	12.72 x 12.72 x 6.38 323 x 323 x 162	Type 12 / IP54	9011	400	50/60	3	.22/.26	2650/2900	14/-10	131/55	70	7.72/3.5	473 (803)	343 (583)
SF1340424RH	12.72 x 12.72 x 6.38 323 x 323 x 162	Type 12 / IP54	7035	400	50/60	3	.22/.26	2650/2900	14/-10	131/55	70	7.72/3.5	473 (803)	343 (583)
SF1340423RH	12.72 x 12.72 x 6.38 323 x 323 x 162	Type 12 / IP54	9011	400	50/60	3	.22/.26	2650/2900	14/-10	131/55	70	7.72/3.5	473 (803)	343 (583)
SF1316524H	12.72 x 12.72 x 6.38 323 x 323 x 162	Type 12 / IP55	7035	115	50/60	1	1.02/1.4	2450/2650	14/-10	131/55	70	7.72/3.5	436 (740)	314 (533)
SF1316523H	12.72 x 12.72 x 6.38 323 x 323 x 162	Type 12 / IP55	9011	115	50/60	1	1.02/1.4	2450/2650	14/-10	131/55	70	7.72/3.5	436 (740)	314 (533)
SF1326524H	12.72 x 12.72 x 6.38 323 x 323 x 162	Type 12 / IP55	7035	230	50/60	1	.51/.74	2550/2750	14/-10	131/55	70	7.72/3.5	436 (740)	314 (533)
SF1326523H	12.72 x 12.72 x 6.38 323 x 323 x 162	Type 12 / IP55	9011	230	50/60	1	.51/.74	2550/2750	14/-10	131/55	70	7.72/3.5	436 (740)	314 (533)
SF1340524H	12.72 x 12.72 x 6.38 323 x 323 x 162	Type 12 / IP55	7035	400	50/60	3	.22/.26	2650/2900	14/-10	131/55	70	7.72/3.5	436 (740)	314 (533)
SF1340523H	12.72 x 12.72 x 6.38 323 x 323 x 162	Type 12 / IP55	9011	400	50/60	3	.22/.26	2650/2900	14/-10	131/55	70	7.72/3.5	436 (740)	314 (533)

Order Exhaust Grille Kit separately.

**SF13 473 CFM (803 M³/Hr.) Side-Mount Filter Fan
 Performance Curve**

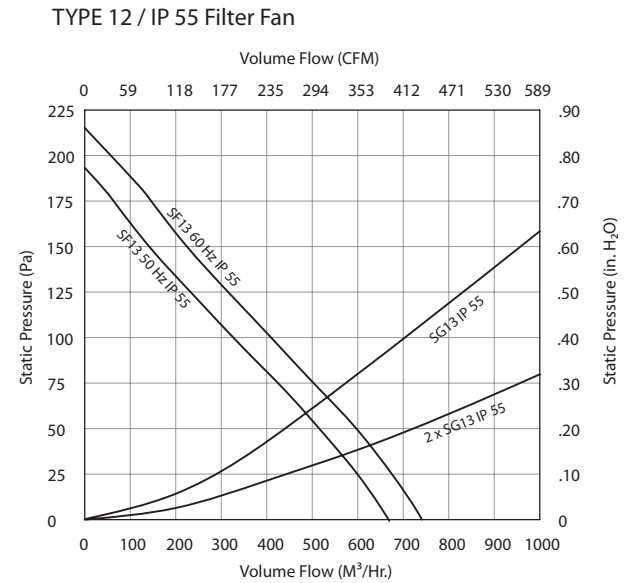
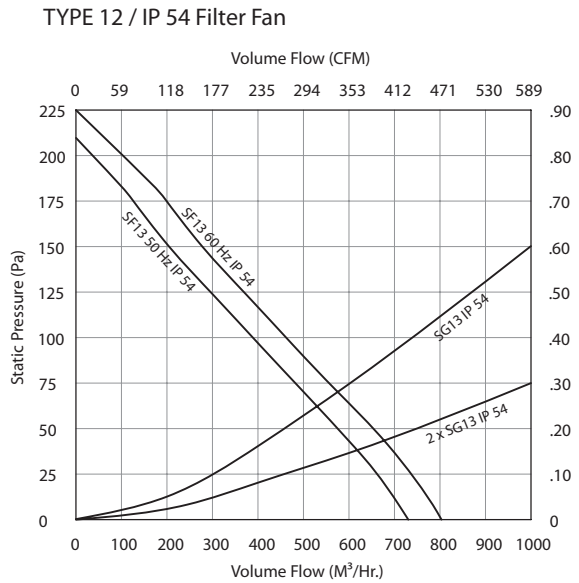

FILTER FAN

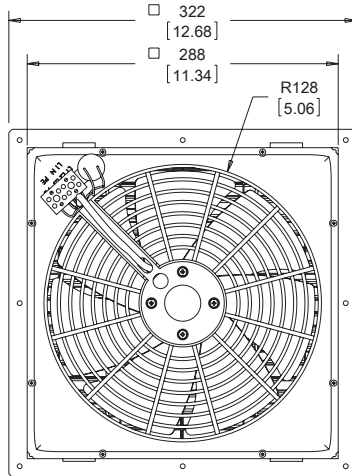

BACK VIEW

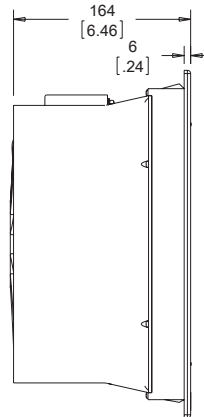

SIDE VIEW

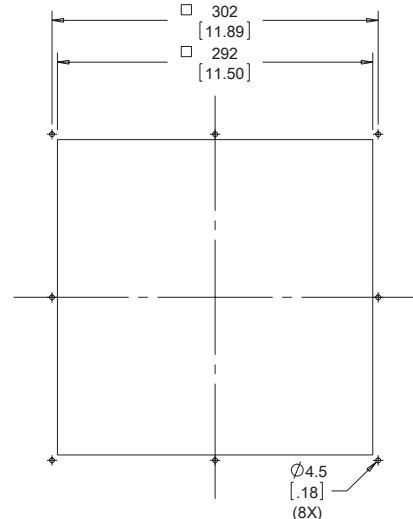

CUTOUT

EXHAUST GRILLE

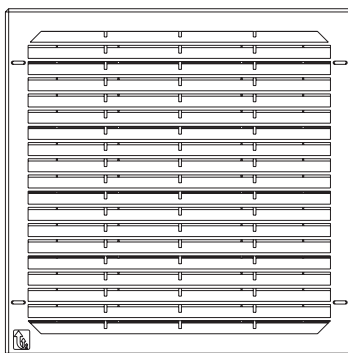

Order Exhaust Grille Kit separately

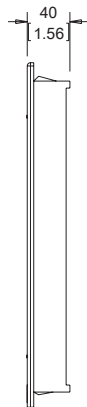

89051223

Filter Fan Packages

SF13 571 CFM (970 m³/hr.) Side-Mount Filter Fan



Features

- Free airflow up to 571 CFM (970 m³/hr.)
- Approximate size 13 in. (325 mm)
- Click-fit design quickly installs into enclosure wall; no tools or screws required
- Enclosure side wall mounting
- Reverse airflow option to increase static pressure
- Standard foam-in-place gasket
- Similar cut-out sizes as other filter fan manufacturers
- Terminal wire connections
- Simple snap-open grille for easy filter replacement

Finish

- RAL 7035 light-gray UV-resistant plastic standard
- RAL 9011 black UV-resistant plastic optional

Industry Standards

UL/cUL recognized, CE, CSA (fan motor only)

Type 12, IP54 standard
Type 12, IP55 optional

Notes

Order Exhaust Grille Kits separately.

Bulletin: MCL

Performance Data SF13 571 CFM (970 m³/hr.) Side-Mount Filter Fan

Catalog Number	AxBxC in.	AxBxC mm	NEMA/ IP Rating	Color	Volt	Hz	Phase	Full Load Amps	Motor RPM	Low Temp. °F/°C	High Temp. °F/°C	Noise dB(A)	Ship Wt. (lb./kg)	Free Airflow CFM (m ³ /hr.)	Free Airflow with 1 Exhaust Grille (m ³ /hr.)
SF1324434H	12.72 x 12.72 x 5.51	323 x 323 x 140	Type 12 / IP54	7035	24	NA	1	5.00	2750	5/-15	140/60	70	10.14/4.6	571 (970)	377 (640)
SF1324433H	12.72 x 12.72 x 5.51	323 x 323 x 140	Type 12 / IP54	9011	24	NA	1	5.00	2750	5/-15	140/60	70	10.14/4.6	571 (970)	377 (640)
SF1348434H	12.72 x 12.72 x 5.51	323 x 323 x 140	Type 12 / IP54	7035	48	NA	1	2.60	2750	5/-15	140/60	70	10.14/4.6	571 (970)	377 (640)
SF1348433H	12.72 x 12.72 x 5.51	323 x 323 x 140	Type 12 / IP54	9011	48	NA	1	2.60	2750	5/-15	140/60	70	10.14/4.6	571 (970)	377 (640)
SF1316434H	12.72 x 12.72 x 5.51	323 x 323 x 140	Type 12 / IP54	7035	115	50/60	1	1.02/1.47	2600/2850	5/-15	140/60	70	10.14/4.6	571 (970)	377 (640)
SF1316433H	12.72 x 12.72 x 5.51	323 x 323 x 140	Type 12 / IP54	9011	115	50/60	1	1.02/1.47	2600/2850	5/-15	140/60	70	10.14/4.6	571 (970)	377 (640)
SF1316434RH	12.72 x 12.72 x 5.51	323 x 323 x 140	Type 12 / IP54	7035	115	50/60	1	1.02/1.47	2600/2850	5/-15	140/60	70	10.14/4.6	571 (970)	377 (640)
SF1316433RH	12.72 x 12.72 x 5.51	323 x 323 x 140	Type 12 / IP54	9011	115	50/60	1	1.02/1.47	2600/2850	5/-15	140/60	70	10.14/4.6	571 (970)	377 (640)
SF1326434H	12.72 x 12.72 x 5.51	323 x 323 x 140	Type 12 / IP54	7035	230	50/60	1	.60/92	2650/2950	5/-15	140/60	69	10.14/4.6	571 (970)	377 (640)
SF1326433H	12.72 x 12.72 x 5.51	323 x 323 x 140	Type 12 / IP54	9011	230	50/60	1	.60/92	2650/2950	5/-15	140/60	69	10.14/4.6	571 (970)	377 (640)
SF1326434RH	12.72 x 12.72 x 5.51	323 x 323 x 140	Type 12 / IP54	7035	230	50/60	1	.60/92	2650/2950	5/-15	140/60	69	10.14/4.6	571 (970)	377 (640)
SF1326433RH	12.72 x 12.72 x 5.51	323 x 323 x 140	Type 12 / IP54	9011	230	50/60	1	.60/92	2650/2950	5/-15	140/60	69	10.14/4.6	571 (970)	377 (640)
SF1346434H	12.72 x 12.72 x 5.51	323 x 323 x 140	Type 12 / IP54	7035	400/460	50/60	3	.25/27	3050	5/-15	140/60	72	10.14/4.6	571 (970)	377 (640)
SF1340434RH	12.72 x 12.72 x 5.51	323 x 323 x 140	Type 12 / IP54	7035	400/460	50/60	3	.25/27	3050	5/-15	140/60	72	10.14/4.6	571 (970)	377 (640)
SF1346433H	12.72 x 12.72 x 5.51	323 x 323 x 140	Type 12 / IP54	9011	400/460	60	3	.27	3050	5/-15	140/60	73	10.14/4.6	571 (970)	377 (640)
SF1346433RH	12.72 x 12.72 x 5.51	323 x 323 x 140	Type 12 / IP54	9011	400/460	60	3	.27	3050	5/-15	140/60	73	10.14/4.6	571 (970)	377 (640)
SF1324534H	12.72 x 12.72 x 5.51	323 x 323 x 140	Type 12 / IP55	7035	24	NA	1	5.00	2750	5/-15	140/60	70	10.14/4.6	526 (893)	345 (586)
SF1324533H	12.72 x 12.72 x 5.51	323 x 323 x 140	Type 12 / IP55	9011	24	NA	1	5.00	2750	5/-15	140/60	70	10.14/4.6	526 (893)	345 (586)
SF1348534H	12.72 x 12.72 x 5.51	323 x 323 x 140	Type 12 / IP55	7035	48	NA	1	2.60	2750	5/-15	140/60	70	10.14/4.6	526 (893)	345 (586)
SF1348533H	12.72 x 12.72 x 5.51	323 x 323 x 140	Type 12 / IP55	9011	48	NA	1	2.60	2750	5/-15	140/60	70	10.14/4.6	526 (893)	345 (586)
SF1316534H	12.72 x 12.72 x 5.51	323 x 323 x 140	Type 12 / IP55	7035	115	50/60	1	1.02/1.47	2600/2850	5/-15	140/60	70	10.14/4.6	526 (893)	345 (586)
SF1316533H	12.72 x 12.72 x 5.51	323 x 323 x 140	Type 12 / IP55	9011	115	50/60	1	1.02/1.47	2600/2850	5/-15	140/60	70	10.14/4.6	526 (893)	345 (586)
SF1326534H	12.72 x 12.72 x 5.51	323 x 323 x 140	Type 12 / IP55	7035	230	50/60	1	.60/92	2650/2950	5/-15	140/60	69	10.14/4.6	526 (893)	345 (586)
SF1326533H	12.72 x 12.72 x 5.51	323 x 323 x 140	Type 12 / IP55	9011	230	50/60	1	.60/92	2650/2950	5/-15	140/60	69	10.14/4.6	526 (893)	345 (586)
SF1346534H	12.72 x 12.72 x 5.51	323 x 323 x 140	Type 12 / IP55	7035	400/460	50/60	3	.25/27	2650/2900	5/-15	140/60	72	10.14/4.6	526 (893)	345 (586)
SF1346533H	12.72 x 12.72 x 5.51	323 x 323 x 140	Type 12 / IP55	9011	400/460	50/60	3	.25/27	2650/2900	5/-15	140/60	72	10.14/4.6	526 (893)	345 (586)

Order Exhaust Grille Kit separately.

Filter Fan Packages

SF13 571 CFM (970 M³/Hr.) Side-Mount Filter Fan Performance Curve

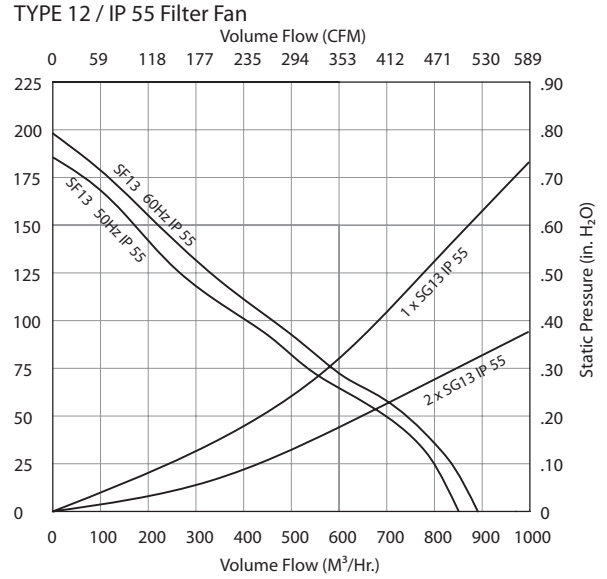
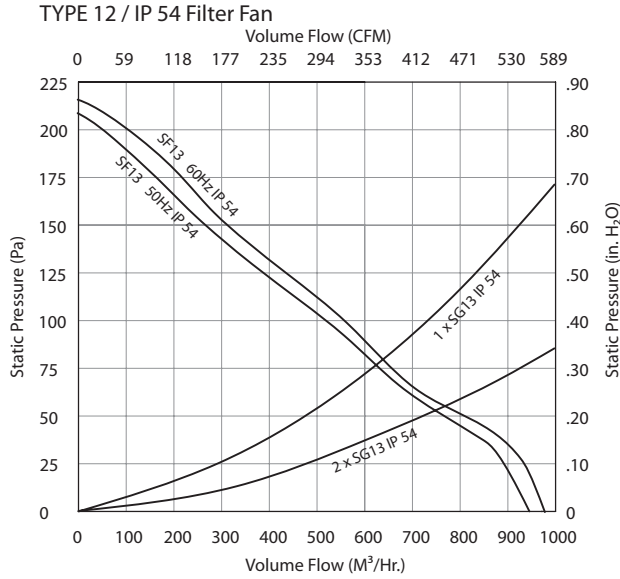

FILTER FAN

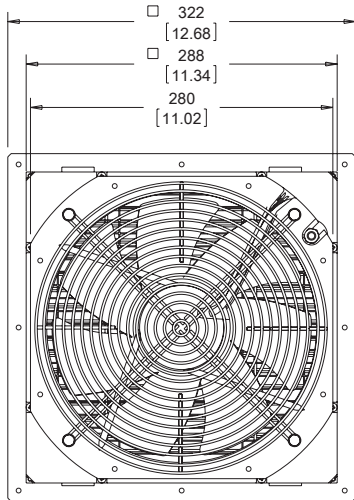

BACK VIEW

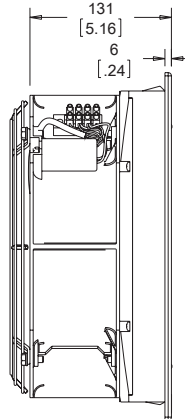

SIDE VIEW

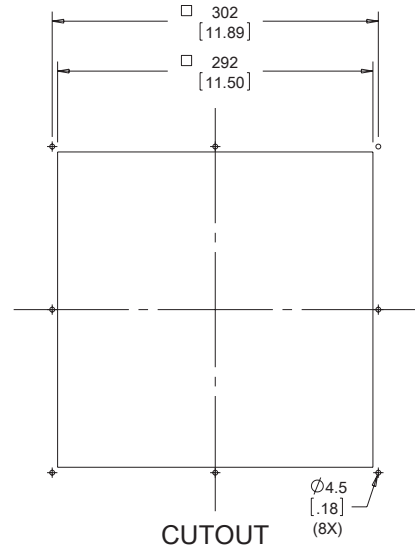

CUTOUT

EXHAUST GRILLE

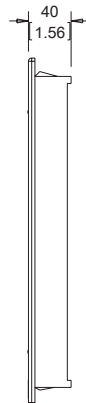
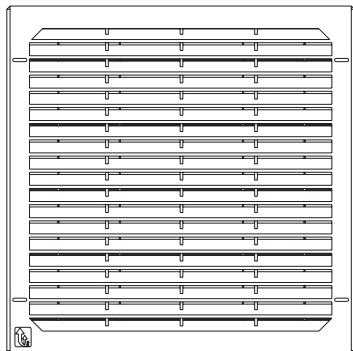

Order Exhaust Grille Kits separately

89051224

Filter Fan Packages

SR16 280 CFM (475 m³/hr.) Roof-Mount Filter Fan



Industry Standards

UL/cUL recognized CE, CSA (fan motor only)

Type 12, IP54 standard

Features

- Free airflow up to 280 CFM (475 m³/hr.)
- Approximate size 16 in. (420 mm)
- Enclosure roof mounting
- Bolt in place to ensure a tight seal
- Terminal wire connections

Finish

- RAL 7035 light-gray UV-resistant plastic standard
- RAL 9011 black UV-resistant plastic optional

Bulletin: MCL

Performance Data SR16 280 CFM (475 m³/hr.) Roof-Mount Filter Fan

Catalog Number	AxBxCin.	AxBxCmm	NEMA/ IP Rating	Color	Volt	Hz	Phase	Full Load Amps	Motor RPM	Low Temp. °F/°C	High Temp. °F/°C	Noise dB(A)	Ship Wt. (lb./kg)	Free Airflow CFM (m ³ /hr.)	Free Airflow with 1 Exhaust Grille (m ³ /hr.)
SR1616414H	16.54 x 16.54 x 1.97	420 x 420 x 50	Type 12 / IP54	7035	115	50/60	1	.35/40	1430/1700	14/-10	140/60	58/62	17.20/7.8	280 (475)	194 (330)
SR1626414H	16.54 x 16.54 x 1.97	420 x 420 x 50	Type 12 / IP54	7035	230	50/60	1	.20/21	1430/1700	14/-10	140/60	58/62	17.20/7.8	280 (475)	194 (330)

SR16 280 CFM (475 M³/Hr.) Roof-Mount Filter Fan Performance Curve

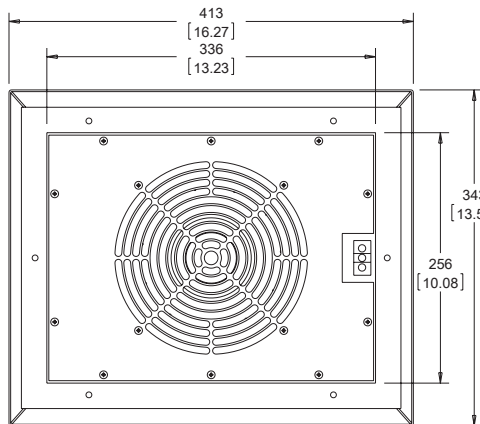
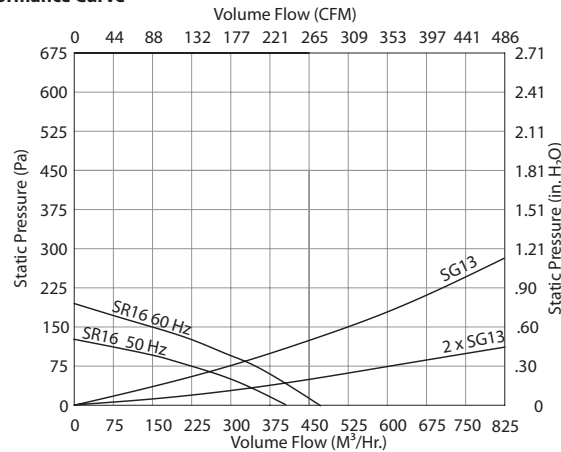

BACK VIEW

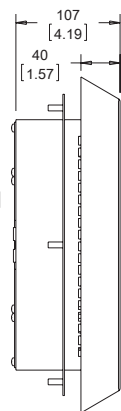

SIDE VIEW

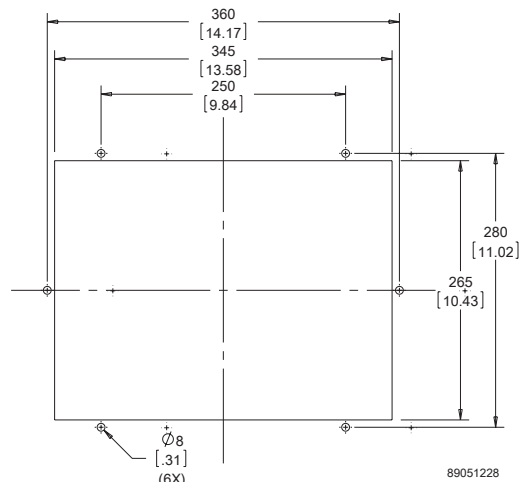

CUTOUT

89051228

Filter Fan Packages

SR16 459 CFM (780 m³/hr.) Roof-Mount Filter Fan



Industry Standards

UL/cUL recognized CE, CSA (fan motor only)

Type 12, IP54 standard

Features

- Free airflow up to 459 CFM (780 m³/hr.)
- Enclosure roof mounting
- Bolt in place to ensure a tight seal
- Terminal wire connections

Finish

- RAL 7035 light-gray UV-resistant plastic standard
- RAL 9011 black UV-resistant plastic optional

Bulletin: MCL

Performance Data SR16 459 CFM (780 m³/hr.) Roof-Mount Filter Fan

Catalog Number	AxBxC in.	AxBxC mm	NEMA/ IP Rating	Color	Volt	Hz	Phase	Full Load Amps	Motor RPM	Low Temp. °F/°C	High Temp. °F/°C	Noise dB(A)	Ship Wt. (lb./kg)	Free Airflow CFM (m ³ /hr.)	Free Airflow with 1 Exhaust Grille (m ³ /hr.)
SR1616424H	16.54 x 16.54 x 1.97	420 x 420 x 50	Type 12 / IP54	7035	115	50/60	1	.60/.80	2650/2950	14/-10	140/60	73/76	18.08/8.2	459 (780)	350 (595)
SR1626424H	16.54 x 16.54 x 1.97	420 x 420 x 50	Type 12 / IP54	7035	230	50/60	1	.55/.73	2650/2950	14/-10	140/60	73/76	18.08/8.2	459 (780)	350 (595)

SR16 459 CFM (780 M³/Hr.) Roof-Mount Filter Fan Performance Curve

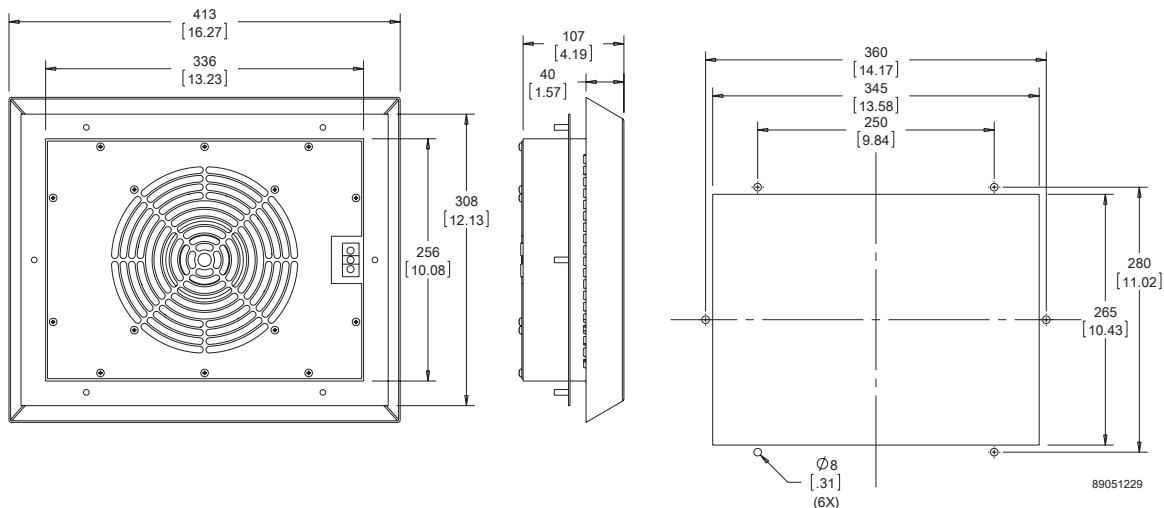
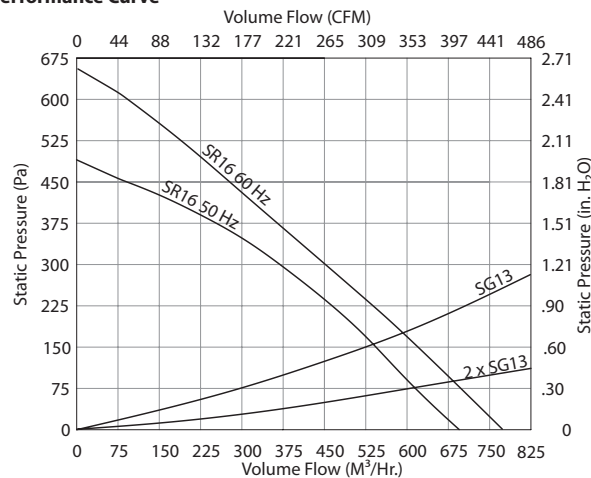

Exhaust Grilles

Use this table to match the right Exhaust Grille to your Filter Fan Package.

Bulletin: MCLY

Catalog Number	Fits Filter Fan Packages
SG0400403H	SF0424413H, SF0448413H, SF0416413H, SF0426413H
SG0400404H	SF0424414H, SF0448414H, SF0416414H, SF0426414H
SG0500403H	SF0524413H, SF0548413H, SF0516413H, SF0526413H
SG0500404H	SF0524414H, SF0548414H, SF0516414H, SF0526414H
SG0500503H	SF0524513H, SF0548513H, SF0516513H, SF0526513H
SG0500504H	SF0524514H, SF0548514H, SF0516514H, SF0526514H
SG0900403H	SF0924413H, SF0948413H, SF0916413H, SF0926413H
SG0900404H	SF0924414H, SF0948414H, SF0916414H, SF0926414H
SG0900503H	SF0924513H, SF0948513H, SF0916513H, SF0926513H
SG0900504H	SF0924514H, SF0948514H, SF0916514H, SF0926514H
SG1000403H	SF1024413H, SF1048413H, SF1016413H, SF1026413H, ST1316514RH, ST1326514H, ST1326514RH
SG1000404H	SF1024414H, SF1048414H, SF1016414H, SF1026414H, ST1316414H, ST1316414RH, ST1326414H, ST1326414RH
SG1000503H	SF1024513H, SF1048513H, SF1016513H, SF1026513H, ST1316513RH, ST1316513RH, ST1326513H, ST1326513RH
SG1000504H	SF1024514H, SF1048514H, SF1016514H, SF1026514H, ST1316413RH, ST1316413RH, ST1326413H, ST1326413RH
SG1300403H	SF1324413H, SF1348413H, SF1316413H, SF1316413RH, SF1326413H, SF1326413RH, ST1316413H, ST1316413RH, ST1326413H, ST1326413RH, SF1316423H, SF1316423RH, SF1326423H, SF1326423RH, SF1326523H, SF1340423H, SF1340423RH, SF1346423H, SF1346423RH, SF1346423H, SF1346423RH, SF1326433H, SF1326433RH, SF1316433RH, SF1326433H, SF1326433RH, SF1346433H, SF1346433RH
SG1300404H	SF1324414H, SF1348414H, SF1316414H, SF1316414RH, SF1326414H, SF1326414RH, ST1316414H, ST1316414RH, ST1326414H, ST1326414RH, SF1316424H, SF1316424RH, SF1326424H, SF1326424RH, SF1340424H, SF1340424RH, SF1346424H, SF1346424RH, SF1324434H, SF1348434H, SF1316434H, SF1316434RH, SF1326434H, SF1326434RH, SF1346434H, SF1346434RH, SR1616414H, SR1616424H, SR1616424H, SR1616424H
SG1300503H	SF1324513H, SF1348513H, SF1316513H, SF1326513H, ST1316513RH, ST1316513RH, ST1326513RH, ST1326513RH, SF1316523H, SF1340523H, SF1346523H, SF1324533H, SF1348533H, SF1316533H, SF1326533H, SF1346533H
SG1300504H	SF1324514H, SF1348514H, SF1316514H, SF1326514H, ST1316514RH, ST1316514RH, ST1326514H, ST1326514RH, SF1316524H, SF1326524H, SF1340524H, SF1346524H, SF1324534H, SF1348534H, SF1316534H, SF1326534H, SF1346534H

Replacement Filters

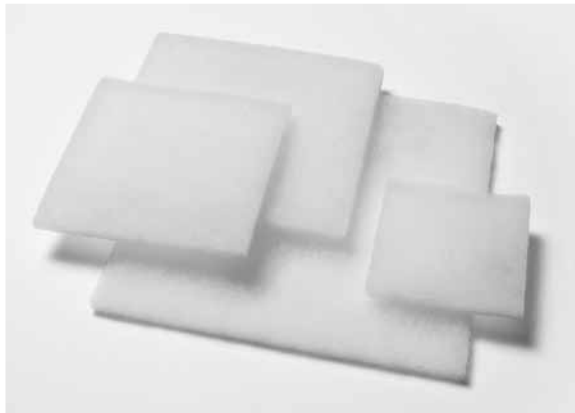

- Type 12 / IP54 filter option provides protection against dust infiltration
- IP55 filter adds additional protection against moisture
- See individual product pages for catalog and item numbers to order

Replacement Filters	Fits Filter Fan Packages
101000059H	SF0424414H, SF0424413H, SF0448414H, SF0448413H, SF0416414H, SF0416413H, SF0426414H, SF0426413H
10100060	SF0524414H, SF0548414H, SF0516414H, SF0526414H, SF0524413H, SF0548413H, SF0516413H, SF0526413H
101000064H	SF0524514H, SF0548514H, SF0516514H, SF0526514H, SF0524513H, SF0548513H, SF0516513H, SF0526513H
10100061	SF0924414H, SF0948414H, SF0916414H, SF0926414H
101000065H	SF0924514H, SF0948514H, SF0916514H, SF0926514H, SF0924513H, SF0948513H, SF0916513H, SF0926513H
10100062	SF1024414H, SF1048414H, SF1016414H, SF1026414H, ST1316414H, ST1316414RH, ST1326414H, ST1326414RH, SF1024413H, SF1048413H, SF1016413H, SF1026413H, ST1316514RH, ST1316514RH, ST1326514H, ST1326514RH
101000066H	SF1024514H, SF1048514H, SF1016514H, SF1026514H, ST1316413RH, ST1316413RH, ST1326413H, ST1326413RH, SF1024513H, SF1048513H, SF1016513H, SF1026513H, ST1316513RH, ST1316513RH, ST1326513H, ST1326513RH
10100063	SF1324414H, SF1348414H, SF1316414H, SF1316414RH, SF1326414H, SF1326414RH, ST1316414H, ST1316414RH, ST1326414H, ST1326414RH, SF1316424H, SF1316424RH, SF1326424H, SF1326424RH, SF1340424H, SF1340424RH, SF1346424H, SF1346424RH, SF1324434H, SF1348434H, SF1316434H, SF1316434RH, SF1326434H, SF1326434RH, SF1346434H, SF1346434RH, SR1616414H, SR1616424H, SR1616424H, SR1616424H, SF1324413H, SF1348413H, SF1316413H, SF1316413RH, SF1326413H, SF1326413RH, ST1316413RH, ST1316413RH, ST1326413H, ST1326413RH
101000067H	SF1324514H, SF1348514H, SF1316514H, SF1326514H, ST1316514RH, ST1316514RH, ST1326514H, ST1326514RH, SF1316524H, SF1326524H, SF1340524H, SF1346524H, SF1324534H, SF1348534H, SF1316534H, SF1326534H, SF1346534H, SF1324513H, SF1348513H, SF1316513H, SF1326513H, ST1316513RH, ST1326513H, ST1326513RH, SF1316523H, SF1340523H, SF1346523H, SF1324533H, SF1348533H, SF1316533H, SF1326533H, SF1346533H

Wind-Driven Rain and Washdown Shroud



Features

- Protects filter fan and exhaust grille from wind-driven rain and high-pressure hose water
- Significantly reduces the possibility of enclosure water infiltration when used in combination with high-density IP55 Z-filter
- Sizes to cover SF05, SF09, SF10 and SF13 filter fans and SG05, SG09, SG10 and SFG3 exhaust grilles
- Mounts separately over filter fan and exhaust grille

Finish

- Stainless steel standard
- RAL 7035 light-gray on galvanized metal optional
- RAL 9011 black on galvanized metal optional

Bulletin: MCL

Catalog Number	AxBxC in./mm	Fits Filter Fan Packages
SH0500005H	8.86 x 7.72 x 2.17 225 x 196 x 55	All SF05 Models
SH0900005H	11.81 x 9.92 x 2.17 300 x 252 x 55	All SF09 Models
SH1000005H	14.76 x 11.73 x 3.15 375 x 298 x 80	All SF10 Models
SH1300005H	18.90 x 14.72 x 3.94 480 x 374 x 100	All SF13 Models

Outdoor Filter Fan and Exhaust Package



Features

- Ball bearing axial fan, service life minimum 50,000 hours at 77 F (25 C) and 65 percent RH
- Airflow 11.8 CFM (20 cubic meters/hour) free blowing
- High-impact plastic is highly weatherproof and resistant to UV light
- Removable F5 filter
- Lockable door in hood
- Two-sided tape provided
- Filter hood permanently fixed to enclosure from inside
- 2 lead wires, 3.94-in. (100-mm) long, with pressure clamps, 14 gauge max. (2.5 mm)
- Synthetic filter material, temperature resistant to 212 F (100 C), self-extinguishing class F1, moisture resistant to 100 percent RH
- Filter mat: Fine grade F5 to DIN EN779 filtering degree: 98 percent of particles larger than 10 µm (10 microns)

Specifications

- Aluminum fan body, plastic impeller

Finish

Light gray plastic, UL94H-B

Bulletin: D85

Industry Standards

CE

cURus File No. E234324

NEMA Type 3R

IEC/EN60529, IP55

Application

This fan package meets basic requirements for outdoor or indoor applications that require warm air dissipation.

Standard Product

Catalog Number	Enclosure Cutout		External Mounting Depth		Internal Mounting Depth		Voltage	Full Load Amps
	in./mm	Description	in./mm	in./mm	in./mm	in./mm		
AOFF118	4.92 x 4.92 125 x 125 (+.4)	Filter Fan	2.56 65	2.44 62	2.44 62	2.44 62	120 VAC, 60 Hz	0.3
AOEFG118	4.92 x 4.92 125 x 125 (+.4)	Exhaust Filter	2.56 65	2.56 65	0.71 18	0.71 18	—	—

AOEFG118 does not include a fan.

Replacement Filter

Catalog Number	Filter Mat 122 x 122 mm
AOFILTER	F5 (3 per package)

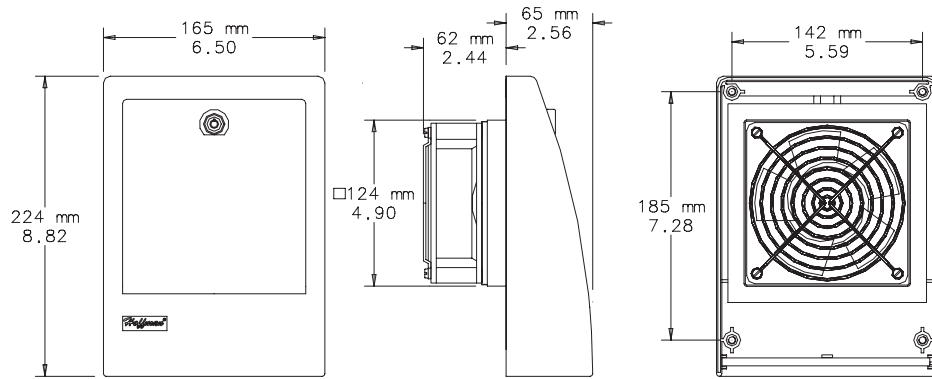

87921431

FILTER FAN

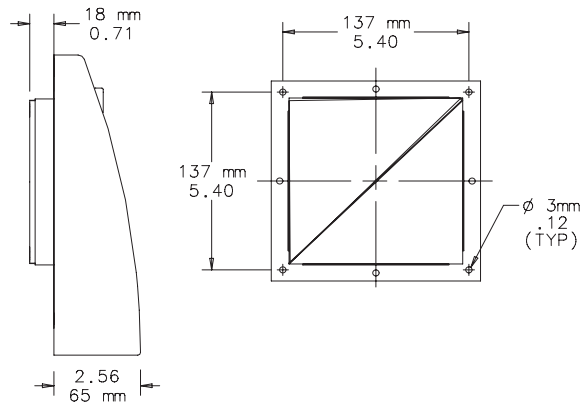

EXHAUST
FILTER

MOUNTING
FRAME

Blower Fan Package

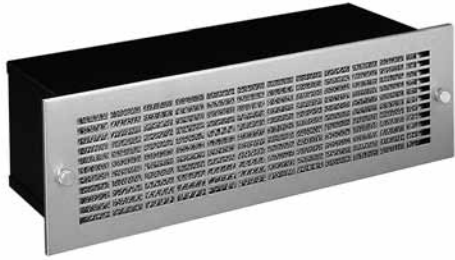

Industry Standards

UL Component Recognized; File No. E61997

EIA RS-310-D
CSA certified
(blower motor only)

Application

For enclosure or 19-in. rack applications, the Blower Fan Package provides the maximum amount of cooling air in the least amount of space by utilizing 115 volt AC, 60/50 hertz, single-phase input power. Engineered for 20,000 hours of continuous operation when properly powered.

Features

- Intake grille is easily removed with two captive thumbnuts
- Washable aluminum filter
- Single phase motor powers the statically balanced blower
- Motor is thermally protected and cooled by incoming forced air
- Direct drive induction motor contains permanently lubricated ball bearings
- Lubricant protects from -20 F to 298 F (-29 C to 148 C)
- Rotating components are suspended on neoprene shock-mounts
- Three-conductor power cord (five feet long)

Installation

Can be mounted as shown below or installed on standard 19-in. (483-mm) racks. The unit is self-supporting with 16 gauge steel flanges notched per EIA RS-310-D. Two openings are required in the enclosure for air to flow in and out. Refer to drawings for size and location of openings. An exhaust grille and filter package (catalog number **AEXGR275**) is required and must be ordered separately. Consult your local Hoffman sales office for information on modifications to this product.

Specifications

- 16 gauge steel housing

Finish

Blower housing is black enamel.
Grille is brushed stainless steel.

Accessories

- Exhaust Grille and Filter
- Filter Adhesive
- Temperature Control Switch
- Bulletin: D85

Standard Product

Catalog Number	AxBxC in./mm	Free Air (CFM)	Watts	Voltage	Hz	Amps	Motor RPM	Noise SIL (dB)	Weight (lb.)	Weight (kg)
ADB275	5.75 x 19.00 x 7.25 146 x 483 x 184	230 / 275	84	115	50 / 60	1.2	2580 / 3100	56	15.00	7.00

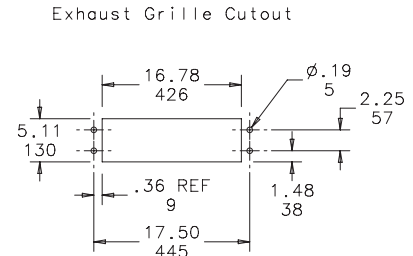
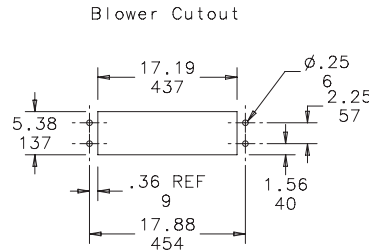
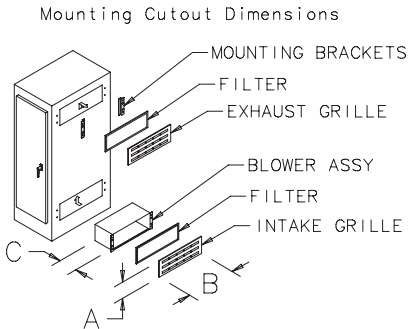

87541398

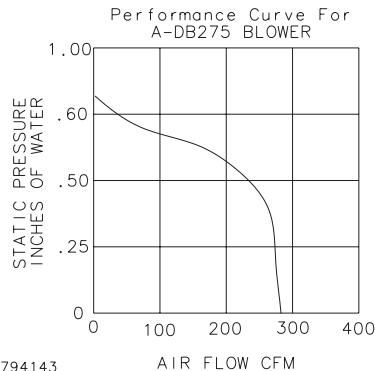

87794143

Blower Fan Package

Exhaust Grille and Filter for Blower Package

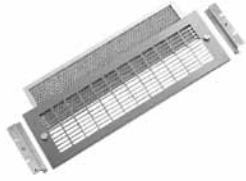

Located at air discharge side of an enclosure using Blower Package ADB275. Polished stainless steel grille is 65 percent open and offers low resistance to airflow. Expanded aluminum filter (included with each grille) is easily removed for cleaning from outside the enclosure. Mounting hardware is furnished.

Bulletin: D85

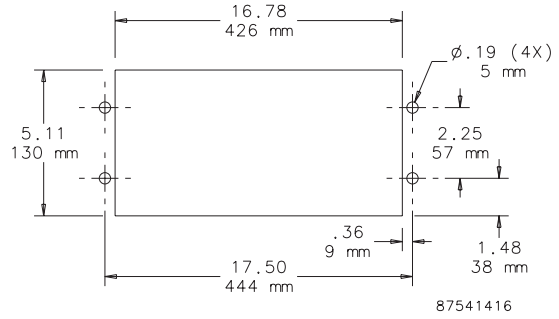

Catalog Number	Dimensions A x B		Filter Size
	in./mm	in./mm	in./mm
AEXGR275	5.75 x 19.00		4.98 x 16.56
	146 x 483		126 x 421

Replacement Filter

Catalog Number	Description	Quantity
AFLTR275AL	Aluminum Filter Replacement	5/pkg.

Filter and Fan Airflow Monitor



Industry Standards

CE

cURus; File No. E250507

IEC EN60529, IP20

Application

The simple, reliable mechanical operation of the Filter and Fan Airflow Monitor makes it a viable alternative to electronic monitoring systems.

Features

- Service life is greater than 100,000 cycles
- Bi-directional switch activates an electrical contact if the airflow of the fan falls below 8.2 ft./sec.
- Monitors airflow to 164 ft./sec. (50 m/s) max.
- Reed/magnet contact
- Switching threshold of air flow speed > 8.2 ft./sec. (2.5 m/s)
- Maximum switching:
 - capacity = 10 W (resistive load)
 - voltage = NC: DC 240 V; NO: DC 60 V
 - current = NC: DC 500 mA; NO: DC 170 mA
- Hysteresis 3.3 ft./sec. (1 m/s) fixed
- Contact resistance, including wire, 370 mΩ
- 2 x single strand AWG 26 connection, 19.69-in. (500-mm) long; 0.20-in. (5-mm) tip of stranded wire stripped/tinned
- Mount with attachment clamp and/or clip or integrated in protective grille (see drawing)
- Mount airflow monitor opening perpendicular to airflow in dust-free and contamination-free environment
- AAFMCNC can be attached directly to cooling and exhaust package grilles
- AAFM120NO can be attached to any 4-in. standard fan

Finish

Black plastic, UL94H-B

Bulletin: D85

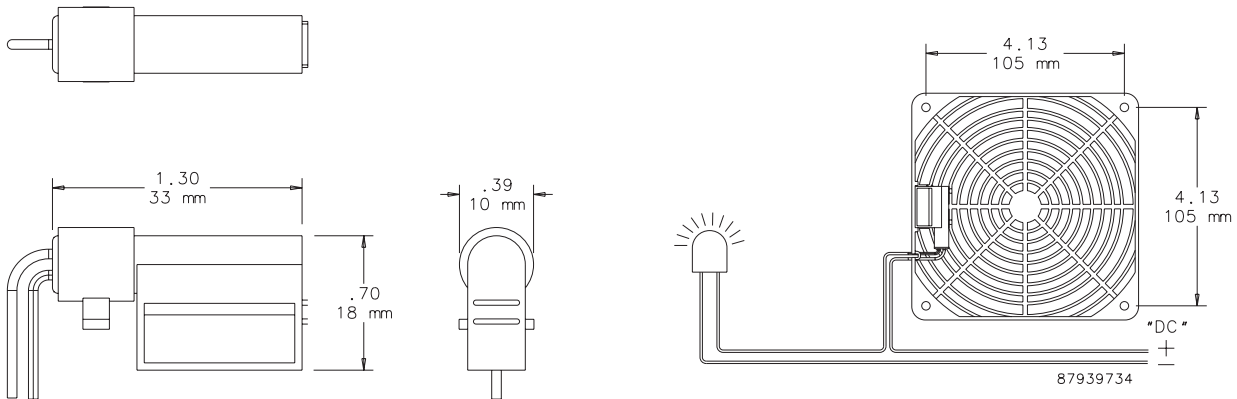

Description	Recommended Use
NC - Normally Closed - Contact opens when airflow greater than 8.2 ft./sec.	Use to turn an alarm or signaling device ON to indicate loss of air flow (less than or = 8.2 ft./sec.)
NO - Normally Open - Contact closes when air flow greater than 8.2 ft./sec.	Use to turn a signaling device ON to indicate sufficient airflow (great than 8.2 ft./sec.)

	Flap Position		Contact	
	≤ 8.2 ft/s	>8.2 ft/s	≤ 8.2 ft/s	>8.2 ft/s
AAFMCNC	 Closed	 Open		
AAFM120NO	 Closed	 Open		

87921540

Fan Speed Controls



Industry Standards

(both controls)

UL 508 Listed; File No. E249700
 cUL Listed per CSA C22.2 No. 14; File No. E249700

Application

Perfect for offices, classrooms and other noise-sensitive areas, Fan Speed Controls optimize airflow in a cabinet or rack, balancing air volume requirements with noise level and power use.

Features

AFANTSC Panel-Mount Fan Speed Control

- Automatically adjusts fan speed depending on remote temperature sensor input
- Temperature set point is field adjustable; preset at 35 C (95 F)
- Idle speed and temperature slope are field-adjustable
- Push-to-reset thermal circuit breaker inside control housing
- Compact polycarbonate control housing can be mounted in any position
- NEMA 5-15R outlet provides power to fan
- Six-foot (1.83-m) power cord plugs into standard 120 V, 50 or 60 Hz outlet
- Remote temperature sensor with 10-ft. (3.05-m) lead mounts in airflow
- Mounting brackets included

A19FANSC 19-in. Rack-Mount Fan Speed Control

- Continuously variable fan speed control knob with minimum speed adjustment
- Uses 1 RU rack space
- Steel construction
- Two NEMA 5-15R outlets provide power to fan
- Six-foot (1.83-m) power cord plugs into standard 120 V 60 Hz outlet

Finish

- AFANTSC: Light-gray polycarbonate control housing
- A19FANSC: RAL 9005 black polyester powder paint

Bulletin: DTHRM

Standard Products

Catalog Number	Description	Application	Voltage and Frequency	Current Draw	Temperature Settings (°C)	Temperature Settings (°F)
AFANTSC	Panel-Mount Fan Speed Control	Fan speed controlled automatically with remote temperature sensor	120 VAC 50/60 Hz	2 A max.	30, 35, 40, 45	86, 95, 104, 113
A19FANSC	19-in. Rack-Mount Fan Speed Control	Fan speed adjusted manually	120 VAC 60 Hz	4 A max.	Continuously variable	Continuously variable

Panel Mount Fan Speed Control

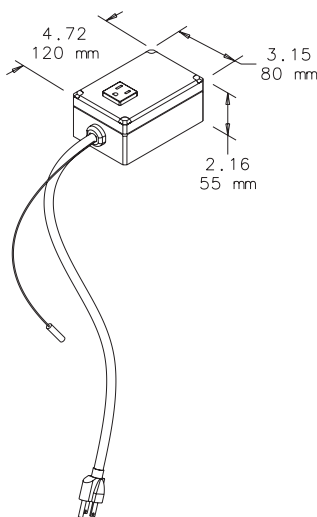

19 inch Rack Mount Fan Speed Control

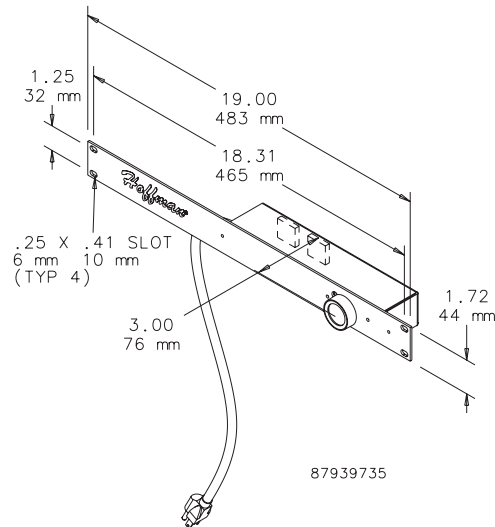

19-in. Rack-Mount Fan Tray **A-T-O**



Application

Fan trays enhance the natural convection airflow within a cabinet when installed with other 19-in. rack-mount equipment.

Features

- Fan trays available with either three or six 4-in. fans
- Includes 72-in. (1829-mm) power cord with IEC 320 standard power socket
- Power cord plugs into standard 115 VAC outlet
- Lighted rocker switch provides on-off control and indicates when fans are on

Finish

RAL 9005 black, lightly textured polyester powder paint

Accessories

Rack mounting hardware

Bulletin: DTHRM

Standard Products

Catalog Number	Number of Fans	Power (W)	Max Airflow (CFM)	C (in.)	C (mm)
A19FT3B	3	45	253	8.10	206
A19FT6B	6	90	506	12.96	329

Technical Performance per 4-Inch Fan

Operating Voltage (VAC)	Operating Frequency (Hz)	Nominal Airflow Capacity (CFM)	Noise Level (dB)	Max. Static Pressure (in. WC)	Max. Operating Temperature (°F)	Max. Operating Temperature (°C)	Power Consumption (W)
115	60	102	41	0.27	158	70	15

Nominal Airflow capacity rating applies to fans before installation in fan tray.

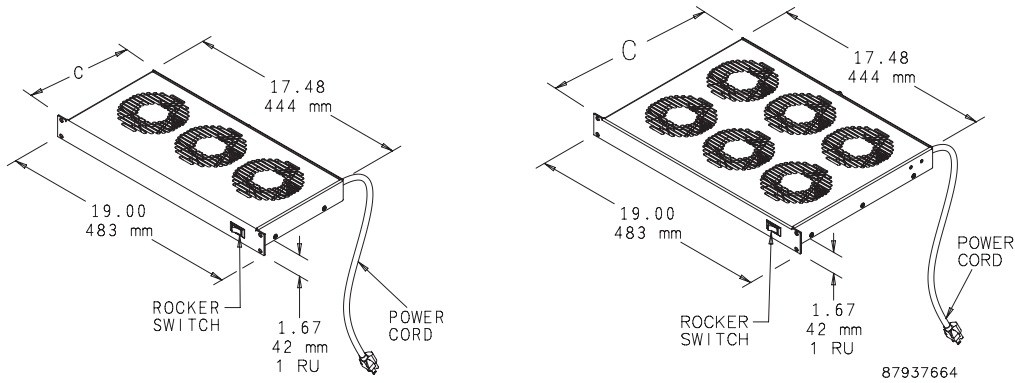

Fan Shroud Kit, Type 3R



Features

- Two fan shrouds per package
- Perforated ventilation screen
- Pressure-sensitive adhesive-backed gasket and mounting hardware

Specifications

- 16 gauge mild steel or Type 304 stainless steel

Finish

ANSI 61 gray polyester powder coating over mild steel; smooth #4 brushed finish on stainless steel

Bulletin: D85

Industry Standards

Maintains UL/cUL Type 3R rating when properly installed on a UL/cUL Type 3R enclosure.

UL 508A Listed; Type 3R; File No. E61997
cUL Listed per CSA C22.2 No. 94; Type 3R; File No. E61997

NEMA/EEMAC Type 3R
IEC 60529, IP22

Application

Fan Shroud Kits protect outdoor enclosure openings from rain, sleet and snow.

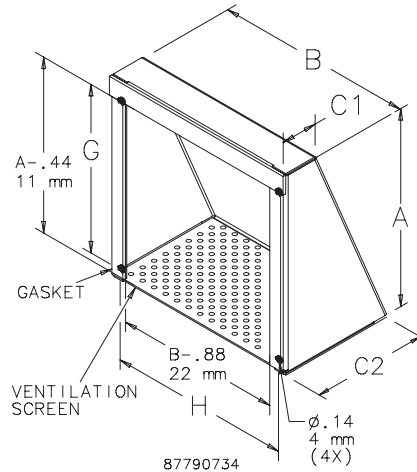

Standard Product

Catalog Number	Material	A (in.)	A (mm)	B (in.)	B (mm)	C1 (in.)	C1 (mm)	C2 (in.)	C2 (mm)	G (in.)	G (mm)	H (in.)	H (mm)
T4S3R	Steel	6.00	152	6.00	152	1.44	37	4.69	119	4.69	119	5.25	133
T6S3R	Steel	8.00	203	8.00	203	1.44	37	4.69	119	6.69	170	7.25	184
T10S3R	Steel	12.00	305	12.00	305	1.44	37	4.71	120	10.69	272	11.25	286
T4S3RSS	Stainless Steel	6.00	152	6.00	152	1.44	37	4.69	119	4.69	119	5.25	113
T6S3RSS	Stainless Steel	8.00	203	8.00	203	1.44	37	4.69	119	6.69	170	7.25	184
T10S3RSS	Stainless Steel	12.00	305	12.00	305	1.44	37	4.71	120	10.69	272	11.25	286

Usage Chart

Catalog Number	Compact Cooling (muffin) Fans (4 in.)	Compact Cooling (muffin) Fans (6 in.)	Compact Cooling (muffin) Fans (10 in.)	Cooling and Exhaust Fan Packages (TFP4-)	Cooling and Exhaust Fan Packages (TFP6-)	Filter Fan Packages (SF05-)	Filter Fan Packages (SF09-)	Filter Fan Packages (SF10-)
T4S3R	•							
T6S3R		•						
T10S3R			•					
T4S3RSS	•							
T6S3RSS		•						
T10S3RSS			•					

Louvers and Vents

Louver Plate Kits

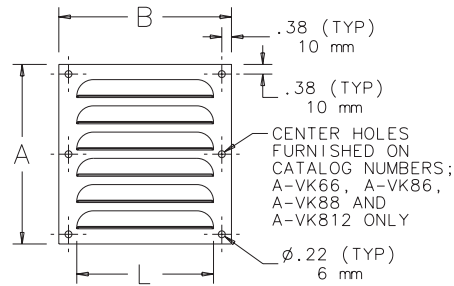

Designed to provide ventilation in enclosures where excessive internal heat or excessive moisture is a problem. Although louvers cannot keep all moisture out of an enclosure, gasketing or sealing the perimeter of the louver plate reduces problems associated with moisture intrusion. These kits may be easily installed in the field by making a cutout of the proper size and attaching the louver plate in place. Louver plates are made from 14 gauge steel with an ANSI 61 gray polyester powder finish over pretreated surfaces or 316 stainless steel. Hardware is furnished for mounting. Custom sizes, materials, finishes, etc., can be provided on special order.

Bulletin: D85

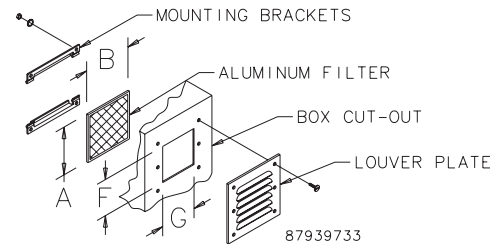

Catalog Number	Dimensions A x B (in.)	Dimensions A x B (mm)	Number of Louvers	Depth D (in.)	Depth D (mm)	Length L (in.)	Length L (mm)	Opening Area (in. ²)	Opening Area (cm ²)	Cutout Size, F (in.)	Cutout Size, F (mm)	Cutout Size, G (in.)	Cutout Size, G (mm)
AVK23	3.25 x 3.25	83 x 83	3	0.19	5	2.00	51	.86	5.54	2.00	51	1.75	44
AVK23SS6	3.25 x 3.25	83 x 83	3	0.19	5	2.00	51	.86	5.54	2.00	51	1.75	44
AVK33	3.88 x 4.50	98 x 114	3	0.25	6	3.00	76	1.32	8.52	2.62	67	3.00	76
AVK33SS6	3.88 x 4.50	98 x 114	3	0.25	6	3.00	76	1.32	8.52	2.62	67	3.00	76
AVK34	4.75 x 4.50	121 x 114	4	0.25	6	3.00	76	1.76	11.35	3.50	89	3.00	76
AVK34SS6	4.75 x 4.50	121 x 114	4	0.25	6	3.00	76	1.76	11.35	3.50	89	3.00	76
AVK43	4.50 x 5.50	114 x 140	3	0.25	6	4.00	102	1.88	12.10	3.25	83	4.00	102
AVK43SS6	4.50 x 5.50	114 x 140	3	0.25	6	4.00	102	1.88	12.10	3.25	83	4.00	102
AVK44	5.62 x 5.50	143 x 140	4	0.25	6	4.00	102	2.50	16.13	4.38	111	4.00	102
AVK44SS6	5.62 x 5.50	143 x 140	4	0.25	6	4.00	102	2.50	16.13	4.38	111	4.00	102
AVK64	5.62 x 7.50	143 x 191	4	0.31	8	6.00	152	5.21	33.61	4.38	111	6.00	152
AVK64SS6	5.62 x 7.50	143 x 191	4	0.31	8	6.00	152	5.21	33.61	4.38	111	6.00	152
AVK66	7.88 x 7.50	200 x 191	6	0.31	8	6.00	152	7.82	50.45	6.62	168	6.00	152
AVK66SS6	7.88 x 7.50	200 x 191	6	0.31	8	6.00	152	7.82	50.45	6.62	168	6.00	152
AVK84	5.81 x 9.50	148 x 241	4	0.31	8	8.00	203	8.08	52.12	4.56	116	8.00	203
AVK84SS6	5.81 x 9.50	148 x 241	4	0.31	8	8.00	203	8.08	52.12	4.56	116	8.00	203
AVK86	8.19 x 9.50	208 x 241	6	0.31	8	8.00	203	12.11	78.13	6.94	176	8.00	203
AVK86SS6	8.19 x 9.50	208 x 241	6	0.31	8	8.00	203	12.11	78.13	6.94	176	8.00	203
AVK88	10.56 x 9.50	268 x 241	8	0.31	8	8.00	203	16.15	104.19	9.31	236	8.00	203
AVK88SS6	10.56 x 9.50	268 x 241	8	0.31	8	8.00	203	16.15	104.19	9.31	236	8.00	203
AVK812	15.31 x 9.50	389 x 241	12	0.31	8	8.00	203	24.22	156.26	14.06	357	8.00	203
AVK812SS6	15.31 x 9.50	389 x 241	12	0.31	8	8.00	203	24.22	156.26	14.06	357	8.00	203

SS6 in catalog number indicates louver plate is Type 316L stainless steel.

Filters for Louver Plate Kits



Design

Designed for use with Louver Plate Kit. Mounting holes on filter bracket align with louver mounting holes. Hardware supplied with louvers also secures filter brackets in place. Aluminum air filters provide good arrestment of airborne dust and dirt.

Filter Media

Filter media is composed of layers of slit and expanded aluminum providing hundreds of adhesive coated baffle surfaces for trapping impurities. Impurities are held throughout the depth of the filter. Washing with warm water will keep the filter clean. To achieve best results, Hoffman Filter Adhesive is recommended.

Bulletin: D85

Catalog Number	Dimensions A x B (in.)	Dimensions A x B (mm)	Use with Steel Louver	Use with Stainless Steel Louver
AFLT33	3.22 x 3.25	82 x 83	AVK33	AVK33SS6
AFLT34	4.09 x 3.25	104 x 83	AVK34	AVK34SS6
AFLT43	3.84 x 4.25	98 x 108	AVK43	AVK43SS6
AFLT44	4.97 x 4.25	126 x 108	AVK44	AVK44SS6
AFLT64	4.45 x 6.25	113 x 159	AVK64	AVK64SS6
AFLT66	6.72 x 6.25	171 x 159	AVK66	AVK66SS6
AFLT84	4.64 x 8.25	118 x 210	AVK84	AVK84SS6
AFLT86	7.02 x 8.25	178 x 210	AVK86	AVK86SS6
AFLT88	9.39 x 8.25	239 x 210	AVK88	AVK88SS6
AFLT812	14.14 x 8.25	359 x 210	AVK812	AVK812SS6

Vent Kit

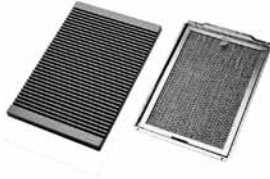

Includes a stylized louvered cover and filter package. Use as an air inlet when a cooling fan is mounted in an enclosure or use two vent kits to allow passive airflow. Mounting hardware included. Vent Kit requires cutout shown in diagram. Available in gray (RAL 7042) or black.

Bulletin: D85, P20

Catalog Number	H x W x D (in.)	H x W x D (mm)	Color
XPV32	11.81 x 7.88 x 1.03	300 x 200 x 26	Gray
PPV32B	11.81 x 7.88 x 1.03	300 x 200 x 26	Black

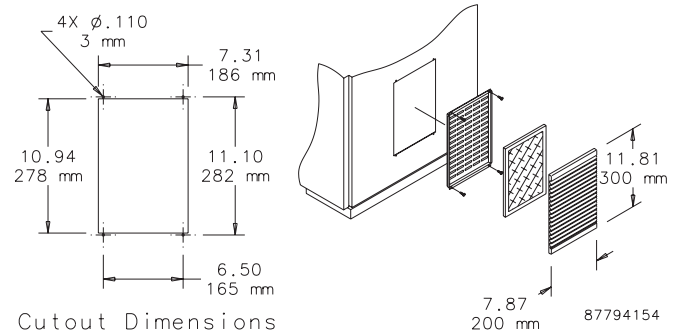

Cutout Dimensions

Ventilators



Designed to fit most metallic and non-metallic enclosures. Proper installation will provide rainproof ventilation but will not meet Type 4 or 12 requirements. Kit includes a ventilator made of fire-retardant thermoplastic material, mounting hardware, and instructions. Supplied screws are 13-mm (.515-inch) long. Some applications may require longer screws.

Bulletin: D85

Catalog Number	Description
ANMV6	Large nonmetallic vent
ANMV3	Small nonmetallic vent

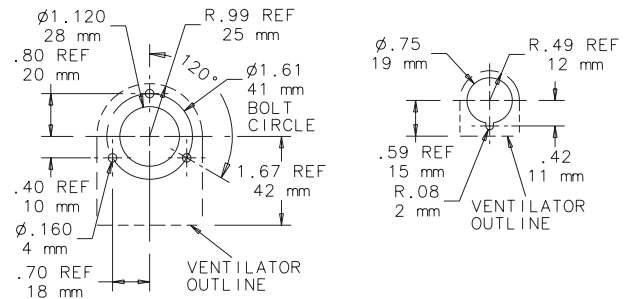

Large Ventilator

Small Ventilator

87541390

Filter Adhesive



Designed to maximize the efficiency of all expanded aluminum air filters. Use of Filter Adhesive doubles the dust-retention capacity of the filter. Adhesive contains a low-viscosity water-soluble oil which absorbs dirt particles trapped on the surface of the filter. Through the circulation of the oil, a renewed impurity-absorbing surface is constantly established. Washing with water will remove dust, dirt and other impurities. Once the filter is dry, re-coat with adhesive.

Bulletin: D85

Catalog Number	Description
AFLTAD	Spray Adhesive



Heaters Sizing and Selection

Heaters Sizing and Selection Overview

When temperatures dip below the minimally acceptable ranges for electronics, our electric heaters can raise the temperature inside enclosures to appropriate levels. Heaters are designed to protect sensitive mechanical, electrical and electronic equipment from the harmful effects of condensation and corrosion. Two styles offer heating powers from 10 W to 800 W.

The graph in "Semiconductor Control Panel Heaters (for 10-60 W Heating Applications)" represents a painted-steel enclosure mounted in a calm-air building interior. The lowest temperature differential between room temperature and enclosure interior must be 10 F+ to prevent humidity and condensation. For outdoor applications, double the heating power requirement.

Semiconductor Control Panel Heaters (for 10-60 W Heating Applications)

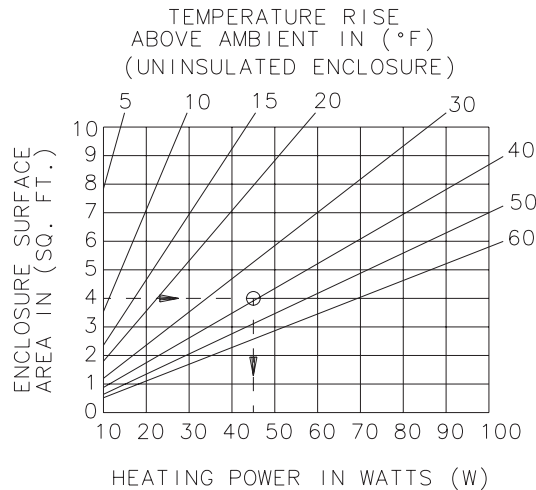
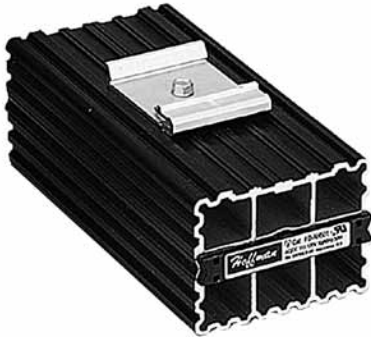

87541410

Step 1:

Plot your application using the graph.

- Find surface area (for example, 4 ft.²) on the vertical scale
- Draw a horizontal line across to the intersection point with the diagonal line representing $\Delta T = 40$ F
- Extend a vertical line down to the horizontal scale to determine your total heating power required (W = 45 W)

Step 2:

From the total Watts required, subtract the 20 W from pre-existing components to arrive at the minimum heater power of 25 W. The 30 W DAH301 heater should be selected in this case since it is the nearest size that exceeds the requirement.

Heaters Sizing and Selection

Electric Heaters (for 100-800 W Heating Applications)



Example:

Which electric heater would most efficiently maintain a 60 F temperature in an uninsulated 24 x 24 x 10 enclosure that is exposed to a temperature not less than 30 F?

Step 1:

Calculate the total enclosure surface area.

- Area (ft.²) = 2[(AxB)+(AxC)+BxC] ÷ 144 where "A", "B" and "C" are the dimensions of the enclosure.

In our example,

- Area = 2[(24x24)+(24x10)+(24x10)] ÷ 144 = 14.7 ft.²

Step 2:

Using the graphs, draw a vertical line through the enclosure surface area and determine the temperature rise given by each heater.

For enclosures exposed to windy conditions, heaters should be oversized by approximately 50 percent.

Step 3:

Select the electric heater that achieves the desired temperature rise.

In our example, the desired temperature rise is 30 F (60 F - 30 F). The 200 W heater should be selected since its temperature rise (35 F) exceeds the requirement.

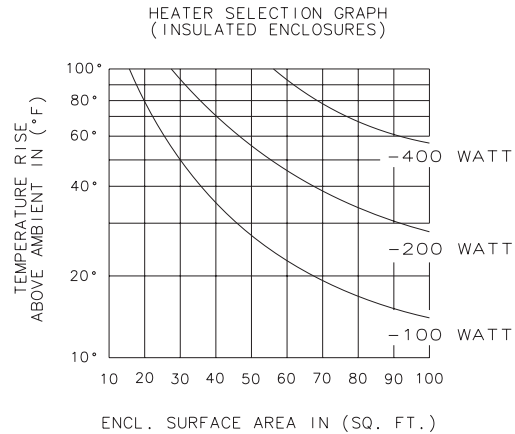
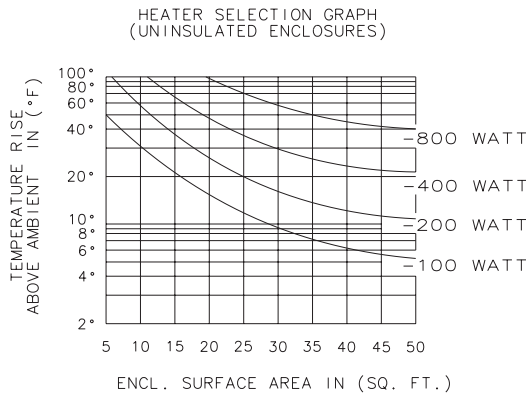

87793520

Semiconductor Control Panel Heaters



Catalog No.	Watts
DAH101	10
DAH301	30
DAH601	60

Electric Heaters

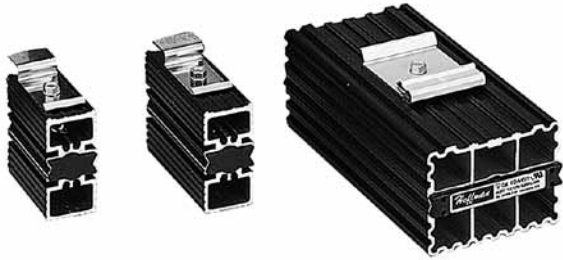

Catalog No.	Watts
DAH1001A	100
DAH1002A	100
DAH2001A	200
DAH2002A	200
DAH4001B	400
DAH4002B	400
DAH8001B	800
DAH8002B	800

Heaters
Semiconductor Control Panel Heater

Industry Standards

UL Component Recognized

CSA Component Recognized
IEC IP54
CE

Application

Protect electronic, pneumatic, hydraulic and mechanical equipment from low temperatures, condensation and corrosion with this heater, which maintains a stable enclosure temperature.

Specifications

- PTC (Positive Temperature Coefficient) heating element
- Mounting clip for 35-mm DIN rails EN 50022

Finish

Black anodized, extruded aluminum.

Bulletin: D85

Standard Product

Catalog Number	Watts	Voltage	Amps Starting Current	L (in.)	L (mm)	Weight (lb.)	Weight (kg)
DAH101	10	AC/DC 110/120	.8	1.97	50	.45	.20
DAH301	30	AC/DC 110/120	1.2	3.93	100	.66	.30
DAH601	60	AC/DC 110/250	2.5	5.5	140	1.10	.50

Heaters

Clearance Range for DAH101 and DAH301

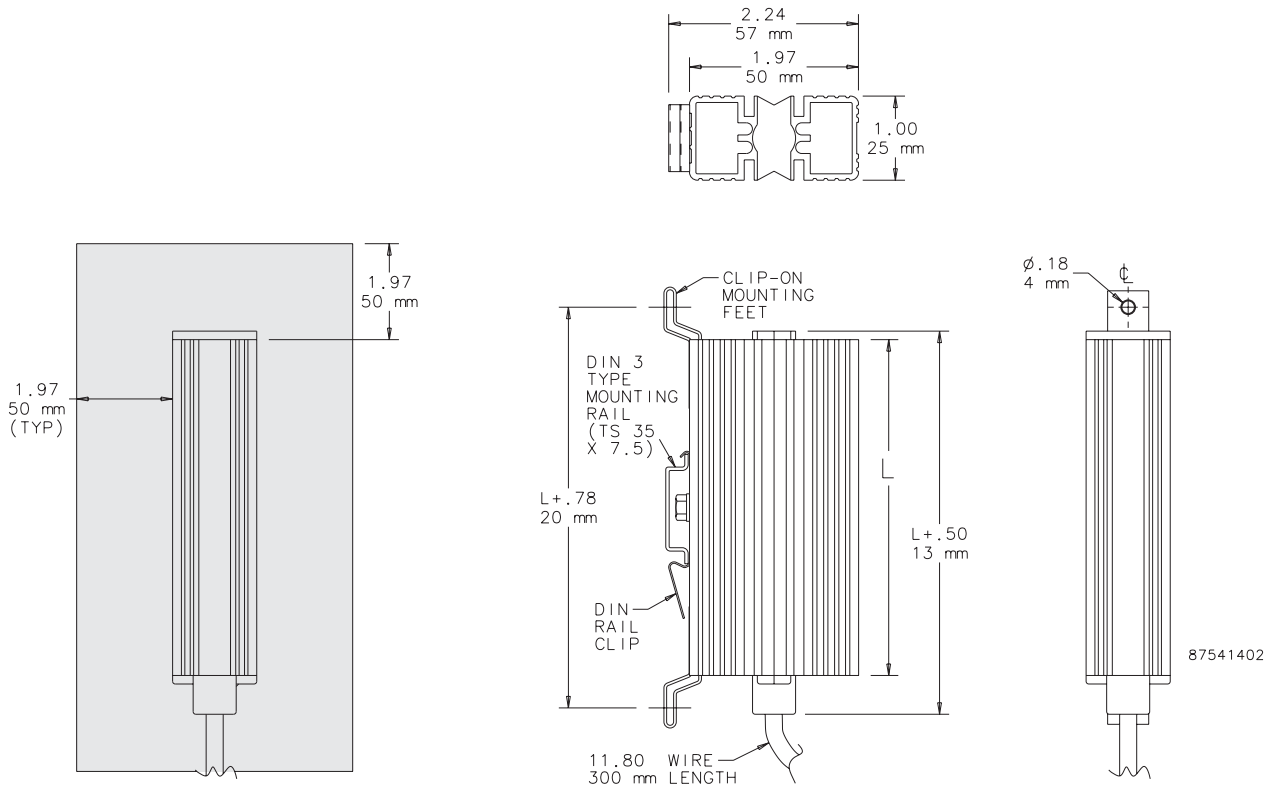

Clearance Range for DAH601

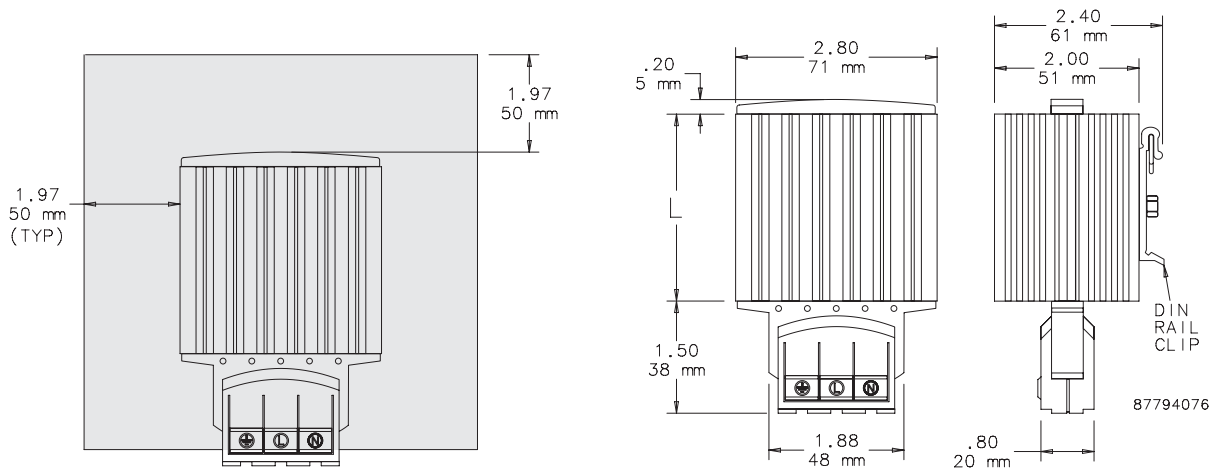

Heaters

Electric Heater



CAUTION

These electric heaters are not designed for use in dusty, dirty, corrosive, or hazardous locations. Portions of the heater can get hot. Adequate protection must be taken to protect people from potential burns, and to protect other components from this heat. Hoffman recommends this heater only be installed in a totally-enclosed metal enclosure.

DO NOT INSTALL HEATERS ON WOOD PANELS.

Heat sensitive components should not be placed near the heater discharge area since this air can be quite warm. The clearance range defines the space that must be kept free of these components for proper and safe operation of the heater.

Industry Standards

UL 508A Component Recognized; File No. E61997

CSA Certified, CSA File No. LR42186
CE

Application

Protect mechanical, electrical and electronic equipment from low temperatures, condensation and corrosion with this thermostatically controlled, fan-driven heater that maintains a stable enclosure temperature.

Fan draws cool air from the bottom of the enclosure and passes this air across the thermostat and heating elements before being released into enclosure cavity. Heated air is discharged through the top of the heater unit.

Specifications

- Aluminum housing
- Thermostat range adjustable from 0 F to 100 F (-18 C to 38 C)
- Four 10-32 x self-tapping screws are included with each heater
- Ball bearing fan
- Terminal strip with clamp connector that accepts both solid and stranded wire

Finish

Brushed aluminum

Bulletin: D85

Standard Product

Catalog Number	Watts	Voltage	Hz	Amps	X in./mm	Weight (lbs.)	Weight (kg)
DAH1001A	100	115	50/60	0.98	4.00 102	4.00	1.81
DAH1002A	100	230	50/60	0.49	4.00 102	4.00	1.81
DAH2001A	200	115	50/60	1.89	6.00 152	4.00	1.81
DAH2002A	200	230	50/60	0.95	6.00 152	4.00	1.81
DAH4001B	400	115	50/60	3.72	6.00 152	6.00	2.72
DAH4002B	400	230	50/60	1.86	6.00 152	6.00	2.72
DAH8001B	800	115	50/60	7.37	8.00 203	6.00	2.72
DAH8002B	800	230	50/60	3.69	8.00 203	6.00	2.72

Heaters

Dimensions and Clearance Range Drawing for DAH1001A, -2A and DAH2001A, -2A

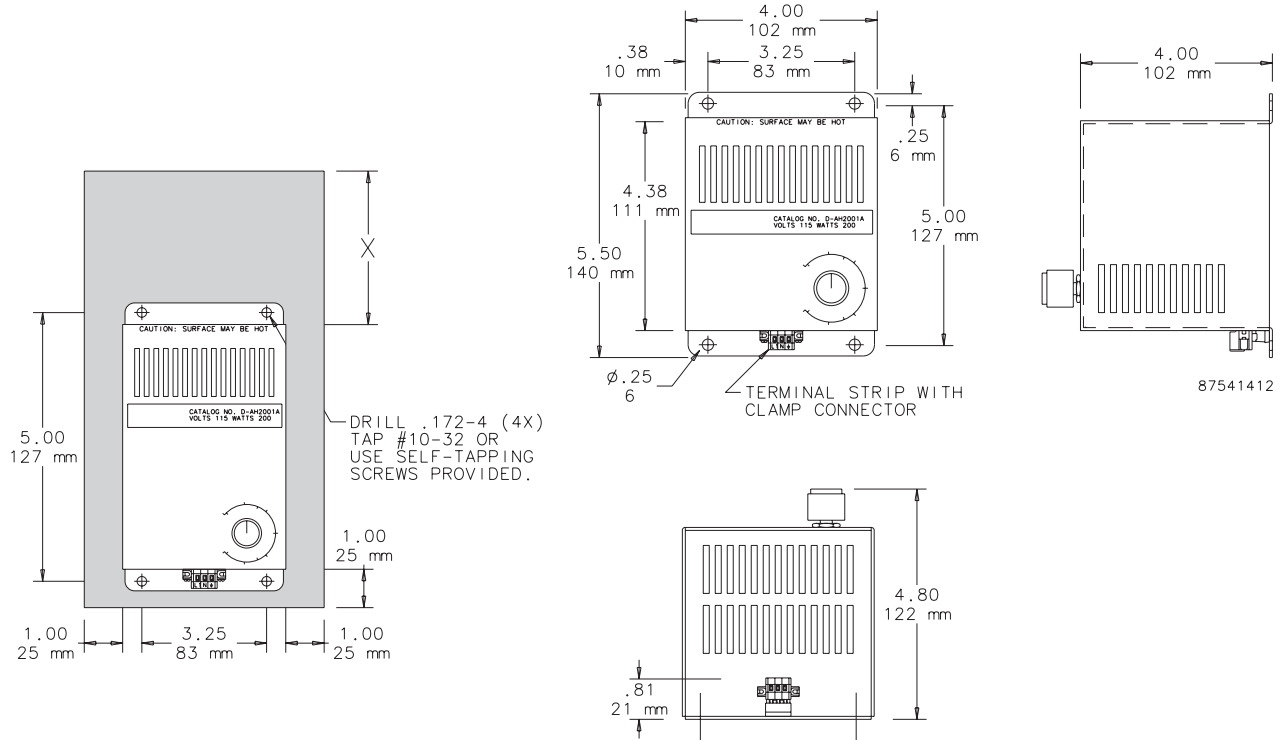

Dimensions and Clearance Range Drawing for DAH4001B, -2B and DAH8001B, -2B

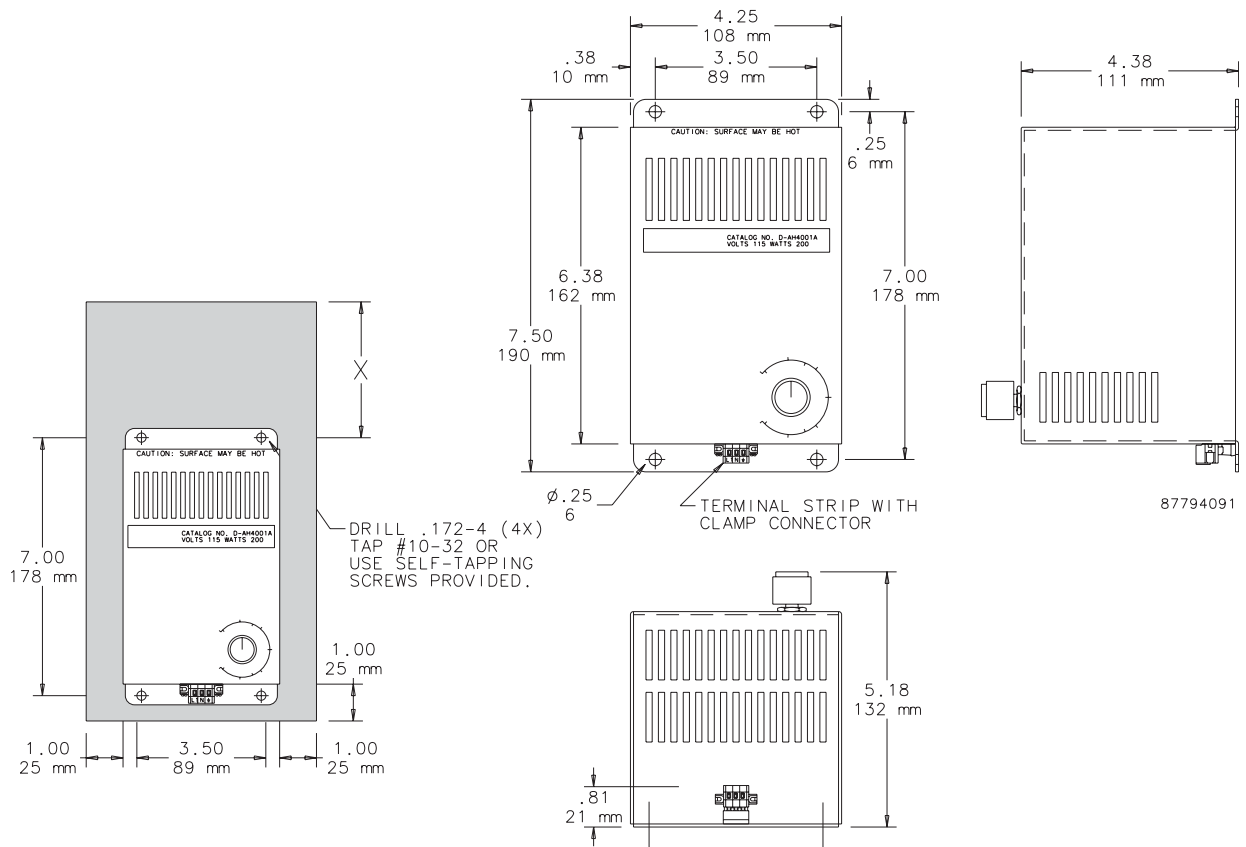

Controllers

Electronic Hygrotherm



Industry Standards

CE

cURus; File No. E164102

Application

The Electronic Hygrotherm senses ambient temperature and relative air humidity and adjusts a connected device to maintain temperature and humidity set points.

Features

- Temperature (32-140 F) and humidity (50%-90% RH) adjustment
- High switching capacity
- Optical function displays (LED) in each control
- Long service life (100,000 cycles NO) (50,000 cycles, NC)
- Mounting clip for 35-mm DIN rail
- Change-over contact (relay)
- Connection: 5-pole terminal for AWG 14 max (2.5-mm square)
- Plastic housing UL94V-0
- Vertical mounting
- Maximum switching capacity:
 - 120 VAC 8A (Resistive Load)
 - 240 VAC 8A (Resistive Load)
 - 120 VAC 3A (Inductive Load)
 - 240 VAC 3A (Inductive Load)
 - 24 VDC 4A

Finish

Light-gray plastic UL94V-0

Bulletin: D85

Standard Product

Catalog Number	AxBxC in.	AxBxC mm	Hysteresis	Humidity Set Point (adjustable)	Temperature Set Point (adjustable) (°F)	Operating Temperature Range (°C)	Storage Temperature (°F)	Storage Temperature (°C)
ATEMHUM	3.03 x 2.36 x 1.69	77 x 60 x 43	~ 3.6 F (2K) ± 1.8 F (1K) tolerance	50-90% RH	32 to 140	0 to 60	-4 to 176	-20 to 80

Relay Output

Contacts	Close at...	Open at...	Use for
3 and 5	humidity rise or temperature drop	humidity drop or temperature rise	heaters, dehumidifiers, low-temp alarms
4 and 5	humidity drop or temperature rise	humidity rise or temperature drop	cooling, humidifiers, high-temp alarms

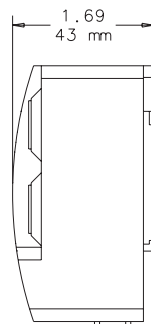
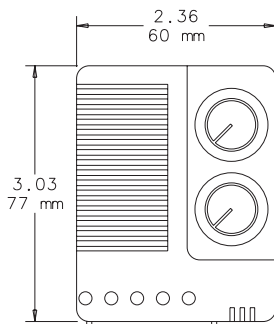
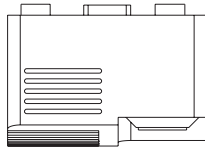

87939706

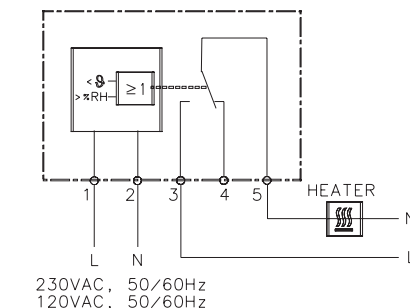
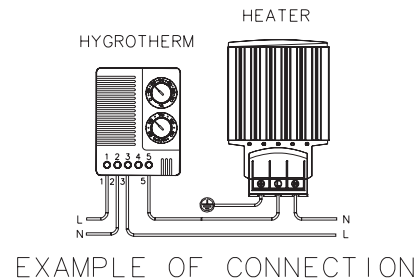

Controllers

Mechanical Hygrostat



Application

The Mechanical Hygrostat controls relative air humidity inside an enclosure to prevent condensation and corrosion that can damage components. It can also be connected to an enclosure heater, cooling fans, warning lights or other devices.

The critical relative humidity (RH) level for most components is 65 percent. Above 65 percent RH, condensation can form and cause electronic equipment to malfunction.

Features

- Adjustable relative humidity range
- High switching capacity
- Long service life (>100,000 cycles)
- Maximum permissible air velocity of 50 ft./sec. (15 m/s)
- Maximum switching voltage = 250 VAC
250 V should be switched only in a non-condensing environment
- Change-over contact
- Mounting clip for 35-mm DIN rail
- Connection: 3-pole terminal for AWG 14 max. (2.5-mm squared)
- Contact resistance less than 10 mΩ

Finish

Light-gray plastic, UL94V-0

Bulletin: D85

Industry Standards

CE

Standard Product

Catalog Number	AxBxCin.	AxBxCmm	Switching Capacity (Minimum)	Switching Capacity (Maximum)	Operating Temperature Adjustable (°F)	Operating Temperature Adjustable (°C)	Storage Temperature (°F)	Storage Temperature (°C)	Setting Range
AMHUM	2.64 x 1.97 x 1.50	67 x 50 x 38	100mA @ AC/DC 20 V	5A @ AC 250 V (resistive load) 0.2A @ AC 250 V (inductive load at cos ϕ = 0.8) DC 20W	32 to 140	0 to 60	-4 to 176	-20 to 80	35 to 95% RH

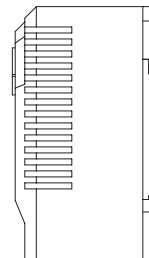
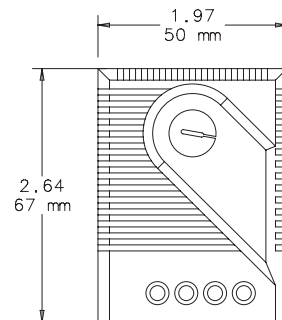
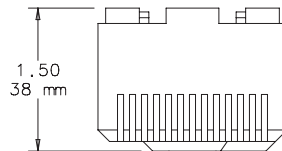

87921430

Controllers

Dual Thermostat



Industry Standards

CE
CSA File No. 215952

cURus; File No. E164102

Application

Two thermostats in one, the Dual Thermostat independently controls equipment heating and cooling systems.

Features

- Two thermostats; one normally closed (NC), red, and one normally open (NO), blue, in one casing
- Wide adjustable temperature range (32 -140 F)
- Thermostatic bimetallic sensor element
- Connection: 4-pole terminal for AWG 14 max (2.5 mm²)
- Mounting clip for 35-mm DIN rail

Finish

Light-gray plastic, UL94V-0

Bulletin: D85

Standard Product

Catalog Number	AxBxC in.	AxBxC mm	Switching Capacity (Normally Closed)	Switching Capacity (Normally Open)	Setting Range (Normally Closed)	Setting Range (Normally Open)
ADLTEMP	2.64 x 1.97 x 1.81	67 x 50 x 46	10 A resistive/2 A inductive @250 VAC, DC 30 W	5 A resistive/2 A inductive @250 VAC, DC 30 W	32-140 F	32-140 F

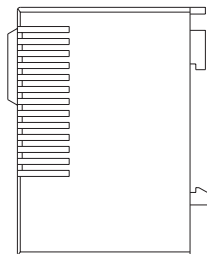
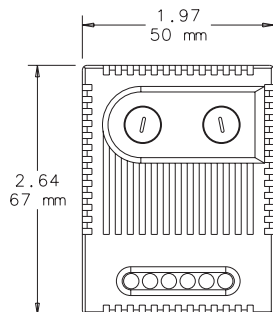
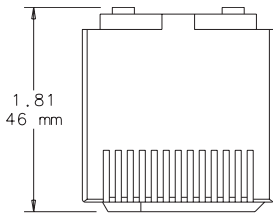

87939707

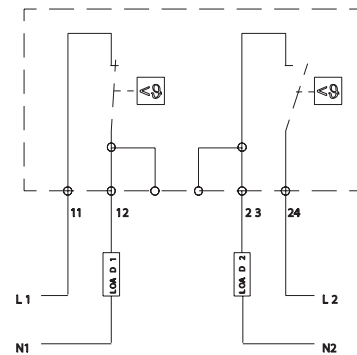

CONNECTION DIAGRAM

Controllers

Temperature Control Switches



Industry Standards

cURus; File No. E164102 UL94-VO

Protection rating IEC IP30
CSA Certified, File Number 215952
CE

Application

These easy-to-install thermostats regulate and monitor air temperature in enclosures that contain heat-emitting equipment. Thermostats prolong heater and fan life expectancy by controlling operation time and increase electrical component working efficiency by exposing them to fewer environmental contaminants.

Features

- Additional label for conversion to Celsius scale and blank label to cover set point range label when adjustment after initial setting is not desired are included
- Bimetal temperature sensor
- Plastic housing
- Connections consist of tubular screw terminals for AWG 14 (.04 sq. in.)
- Provision for both panel mounting and DIN rail mounting

Finish

Molded plastic housing is black

Bulletin: D85

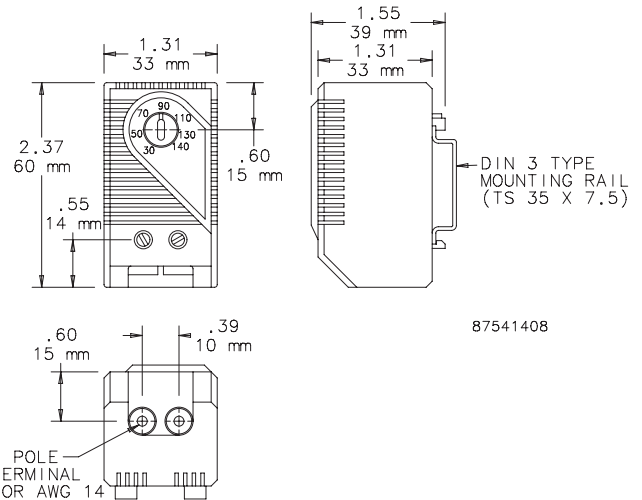

Standard Product

Catalog Number	Contact Type	Control Application
AEMNC	NC (normally closed), quick acting	Heater
AEMNO	NO (normally open), quick acting	Fan

Switching Capacity

Load	Amps
Maximum load	15 A resistive / 2 A inductive @ 120 VAC
	10 A resistive / 2 A inductive @ 250 VAC
	DC 30 W
Minimum load	20 mA (all voltages)

Condensation Devices

H2OMIT® Vent Drains, Type 4X

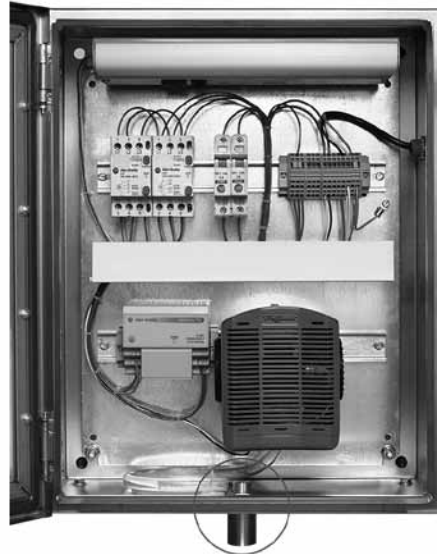

Industry Standards

Maintains UL/cUL Type 4, 4X rating when properly installed on a UL/cUL Type 4 or 4X enclosure.

UL 508A Listed; Type 4, 4X; File No. E61997
 cUL Listed per CSA C22.2 No 94; Type 4, 4X; File No. E61997

NEMA/EEMAC Type 4, 4X

Application

H2OMIT® Vent Drains allow accumulated water to drain out the bottom of an enclosure. The UL-approved vent drains also function as an air pressure equalizer, reducing the harmful effects of temperature-induced vacuums that could pull water and moisture into the enclosure.

Features

- Uses gravity to remove collected liquids
- One-way mechanical shut-off when pressure is equalized prevents water and contaminants from entering the enclosure
- Helps reduce corrosion that can limit the life of internal electrical and electronic components
- Installs in a 7/8-in. hole in the bottom of enclosure with provided nut or in a 1/2-in. NPT/NPS threaded conduit hub
- Installs in the bottom of mild steel, aluminum, stainless steel or non-metallic enclosures
- Maintains enclosure's UL Type rating when properly installed

Specifications

Stainless Steel Vent Drain

- Corrosion-resistant polyester material with a Type 304 stainless steel sleeve
- 2.00-in. long x 1.38-in outside diameter

Non-Metallic Drain Vent

- Corrosion-resistant polyester material
- 2.00-in. long x 1.25-in. outside diameter

Bulletin: H2O

Standard Product

Catalog Number	Description	D (in.)	D (mm)	Quantity
AVDR4NM	Non-metallic Vent Drain	1.25	32	1
AVDR4SS4	Stainless Steel Vent Drain	1.38	35	1

Condensation Devices

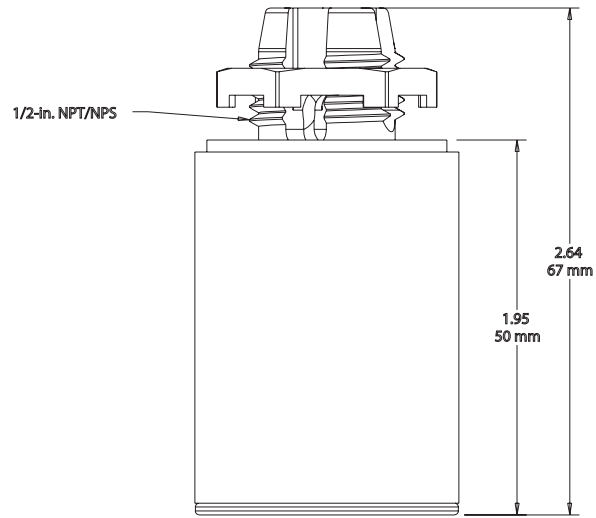
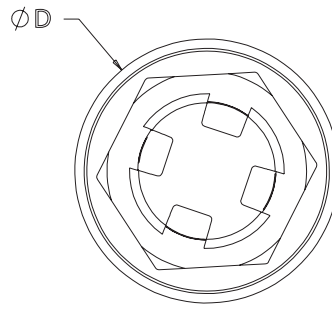

87937537

Condensation Devices

H2OMIT® Thermoelectric Dehumidifier

 Vent Drain
Sold Separately

Industry Standards

UL 508A Listed; File No. E61997 cUL Listed per C22.2 No. 14; File No. E61997

CE

Application

The H2OMIT® Thermoelectric Dehumidifier removes moisture from the air within an enclosure, providing an inexpensive yet highly effective way to protect electronic and electrical components from condensation.

Features

- Reduces corrosion that can limit the life of internal electrical and electronic components
- Condenses moisture from internal enclosure air and standing liquids
- Built-in drain provision with plastic hose directs collected moisture to the Vent Drain (sold separately)
- Rotating side air vents direct recirculating air away from critical controls
- Mounts via DIN rail on internal panel or mounts directly onto the inside bottom of enclosure above the Vent Drain (sold separately)
- Can be used in mild steel, aluminum, stainless steel and non-metallic enclosures

Specifications

- High-impact ABS shell
- Operates on 24-Volt DC power
- 4.5 A max. (84 W)
- Runs continuously above 32 F^a (power supply not included)
- Removes 8 oz. of moisture in 24 hours
- Compact 6.00-in. x 5.50-in. x 5.75-in. design
- One Thermoelectric Dehumidifier includes:
 - Four feet of plastic hose
 - Two hose retainers
 - One double-ended hose retainer
 - Six inches of Velcro®
 - Seven-inch strip of DIN rail
 - Two mounting screws

Must be used with UL-certified drain to remove pooled liquid from enclosure.

^aIf continual operation is not desired, a Mechanical Hygrostat (AMHUM) can be wired to the thermoelectric dehumidifier and then set to turn the dehumidifier on at the desired relative humidity.

VELCRO is a trademark of Velcro Industries B.V.

Bulletin: H2O

Standard Product

Catalog Number	Description
H2OMITTER	Thermoelectric Dehumidifier

Condensation Devices

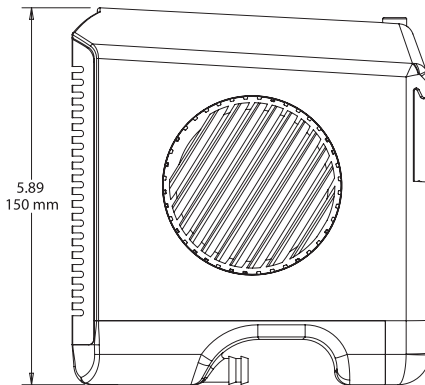
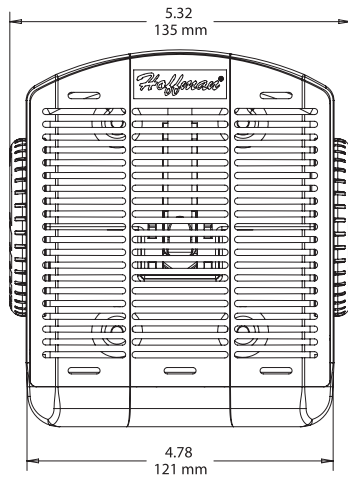
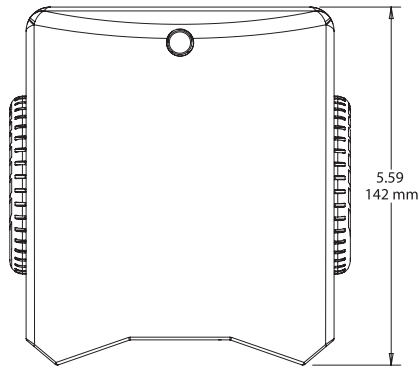

87937538

Dew Point Temperature Percent Relative Humidity

Temp. (° F)	100%	95%	90%	85%	80%	75%	70%	65%	60%	55%	50%	45%	40%	35%	30%	25%	20%	15%	10%
110	110	108	106	104	102	100	98	95	93	90	87	84	80	76	72	65	60	51	41
105	105	103	101	99	97	95	93	91	88	85	83	80	76	72	67	62	55	47	37
100	100	99	97	95	93	91	89	86	84	81	78	75	71	67	63	58	52	44	32
95	95	96	92	90	88	86	87	81	79	76	73	70	67	63	59	54	48	40	32
90	90	88	87	85	83	81	79	76	74	71	68	65	62	59	54	49	43	36	32
85	85	83	81	80	78	76	74	71	69	67	64	61	58	54	50	45	38	32	—
80	80	78	77	75	73	71	69	67	65	62	59	56	53	50	45	40	35	32	—
75	75	73	72	70	68	66	64	62	60	58	55	52	49	45	41	36	32	—	—
70	70	68	67	65	63	61	59	58	55	53	50	47	44	40	37	32	—	—	—
65	65	63	62	60	59	57	55	53	50	48	45	42	40	36	32	—	—	—	—
60	60	58	57	55	53	52	50	48	45	43	41	38	35	32	—	—	—	—	—
55	55	53	52	50	49	47	45	43	40	38	36	33	32	—	—	—	—	—	—
50	50	48	46	45	44	42	40	38	36	34	32	—	—	—	—	—	—	—	—
45	45	43	42	40	39	37	35	34	32	—	—	—	—	—	—	—	—	—	—
40	40	39	37	35	34	32	—	—	—	—	—	—	—	—	—	—	—	—	—
35	35	34	32	—	—	—	—	—	—	—	—	—	—	—	—	—	—	—	—
32	32	—	—	—	—	—	—	—	—	—	—	—	—	—	—	—	—	—	—

Definition: Dew Point is the temperature at which condensation forms. If the temperature of the enclosure is 85 F and the relative humidity is 80 percent, Dew Point is reached at a temperature of 78 F or below.

This means that moisture vapor will condense on any surface that is below the Dew Point temperature of 78 F.